

# 1990 Jeep YJ Optional Rear Window Wiper/Washer Harness

On page 2 you will find the terminals, sleeves, clips and harness assemblies included in the 510807 Rear Window Wiper/Washer Kit. The instructions on this page and illustrations on pages 3-6, along with the items from page 2 will be used to complete your Rear Window Wiper/Washer Harness connections.

**NOTE:** Any 1990 Jeep YJ equipped with a hardtop was available with an optional rear window wiper/washer system. This new AAW harness will plug into your original dash mounted switch, rear wiper motor, and rear washer pump (these components are not included in this kit).

## **Directions for Rear Wiper Dash Harness A:**

1. Plug the loaded 6-position connector and pigtail assembly on this harness into the dash/main harness (510743) optional accessory connector plug as shown on page 3 of this instruction set (Also see page 7 of the 510742 main instruction set, and page 2 of the optional 510797 Rear Defroster harness if your vehicle has that option). **NOTE:** You will need to remove the existing mating plug from the dash accessory connector that was plugged in at AAW prior to installing this new connector. Next, plug that loose connector into the pigtail on the defroster harness. If you require other 12-volt ignition, battery or accessory fused power feeds, use the 4" pigtail connector lead provided on your new Rear Wiper/Washer Harness; this will replace the pigtail included in the Classic Update dash once the rear wiper harness has been installed. This operation is shown on page 3 of this instruction set. In the event that your vehicle also has the Rear Defroster option, that harness will plug in here as well. Just stack the connectors in series with each other. If needed, the terminals to make any extra plug-in connections are located in the loose piece parts kit of the 510743 dash kit.

2. Route the right-hand end of the "Rear Wiper Dash Harness A" up over top of the steering column then down to the rear wiper/washer switch in the lower dash assembly and plug it onto the switch. See the photos on page 3.

3. Route 2-way connector containing the purple and white wires from the "Rear Wiper Dash Harness A" over to the rear body harness plug-in area. The mating 2-way connector containing the purple and white wires on the "Rear Wiper Dash to Rear of Vehicle Harness B" will plug into this connector in step 4.

## **Directions for Rear Wiper Dash to Rear of Vehicle Harness B:**

4. In the rear body harness plug-in area under the dash, plug the 3-way connector containing the red, black and purple/white stripe wires from the "Rear Wiper Dash to Rear of Vehicle Harness B" into the Rear Body Connector #4 shown on page 7 of the 510742 main instructions set.

5. Plug in the 2-way connector containing the purple and white wires on the "Rear Wiper Dash to Rear of Vehicle Harness B" into the mating connector on the "Rear Wiper Dash Harness A" (see step 3 above).

6. Route this "Rear Wiper Dash to Rear of Vehicle Harness B" down under the door opening and to the rear of the vehicle just as you did with the rear body harness on the 510746 rear body harness assembly so that the 2-way and 3-way weather pack connectors are located in the left rear of the vehicle.

## **Directions for Rear Wiper Hardtop Harness C:**

**NOTE:** This new rear wiper hard top harness is intended to replace your original hard top harness. You will need to attach the new harness to the inside of your hard top assembly.

7. In the left rear corner of the vehicle, you should have a 2-way and a 3-way weather pack connector from the "Rear Wiper Dash to Rear of Vehicle Harness B" from step 6 above. Plug the mating connectors from "Rear Wiper Hardtop Harness C" into these connectors, route the harness to the top of the hardtop, over to the wiper motor assembly and plug the 3-way connector onto your motor assembly. We have provided a Clip, "G" to snap into the bracket at the lower rear of the hardtop which will hold your wiper and dome light harnesses into the lower left corner of the hardtop (see the photo on page 5 of this instruction set). Your dome lamp wiring "D" will also route through this clip assembly.

## **Directions for Dome Light Hardtop Harness D:**

**NOTE 1:** This new dome light hard top harness is intended to replace your original hard top harness. You will need to attach the new harness to the inside of your hard top assembly.

**NOTE 2:** This hardtop dome light harness will not be used if your vehicle has the rear defroster option and you have purchased the 510797 kit (available separately at an extra cost). You will use the dome light hardtop harness found in that kit instead.

8. You have options on the dome lamp wiring with the new hardtop harness. Route the orange and white dome lamp wires to the dome lamp assembly area. Follow the installation instructions as shown on page 6 of this instruction set.

## **Directions for Rear Washer Pump Harness E:**

9. Obtain the "Rear Washer Pump Harness E" and plug the black and purple/white stripe wires with the bare terminals into the 10-way front light bulkhead connector located in the engine compartment. See page 30 of the 510472 main instruction set. Also see page 5 of this instruction set for details.

10. Plug the black 2-way connector with the black and purple/white stripe wires onto the rear washer pump on the washer reservoir under the hood.





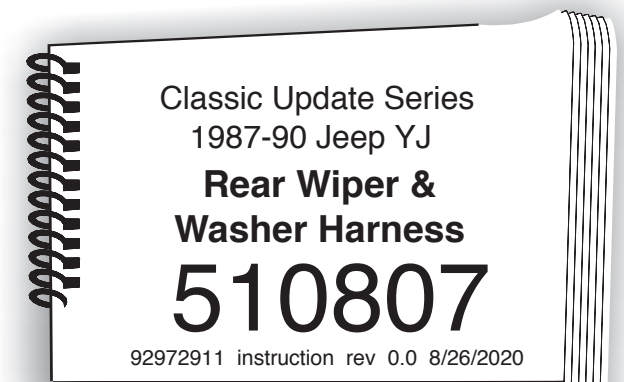

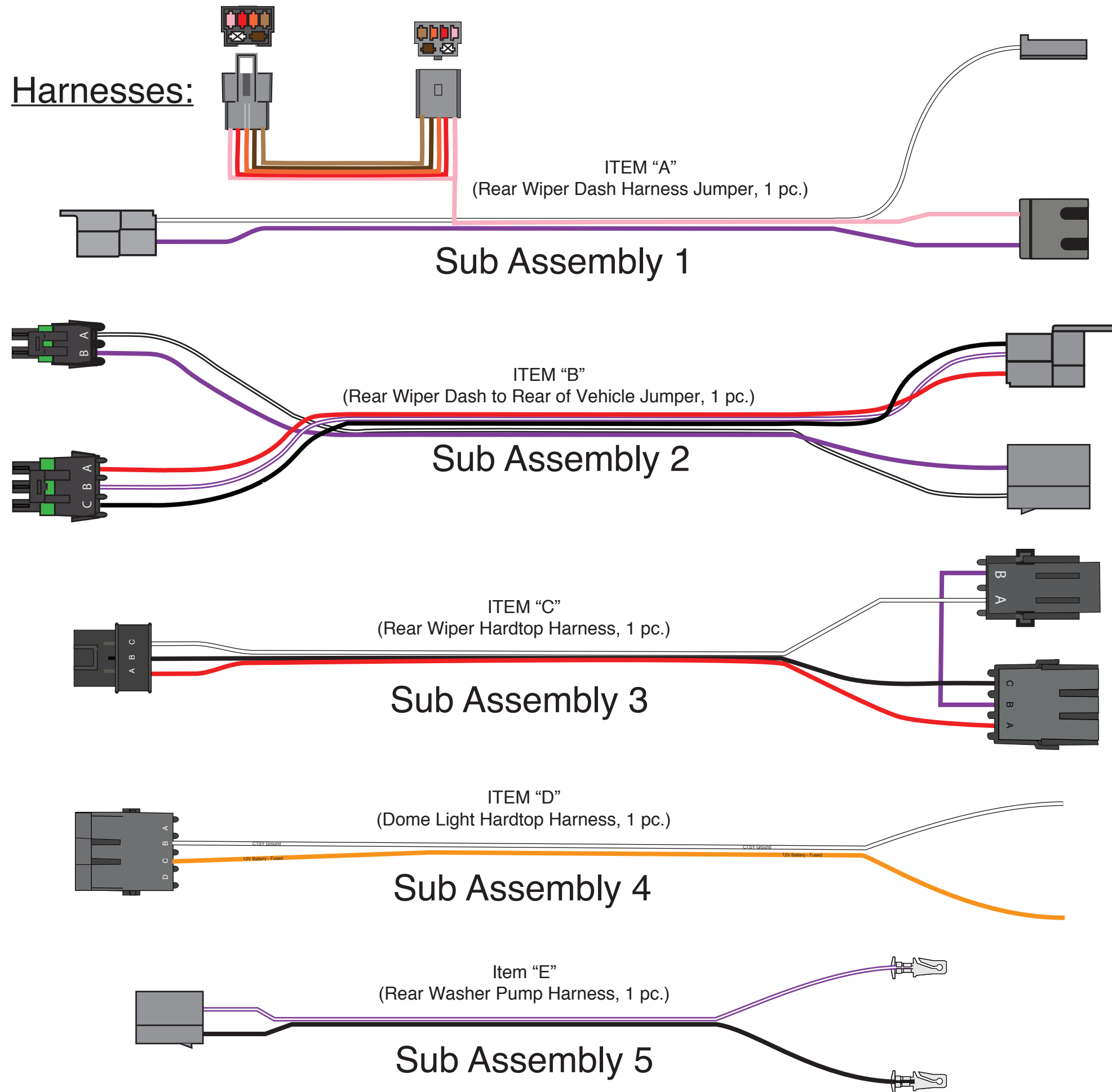

www.americanautowire.com 856-933-0801

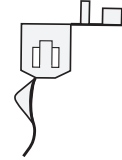

**Harnesses:**



**Loose pieces:**

- F  (Terminal, Dome Light, 3 pcs)
- G  (Clip, 1 pc)
- H  (Male Bullet, small, 3 pcs)
- J  (Sleeve, rubber small, 3 pcs)
- K  (Female Bullet, 3 pcs)
- L  (Sleeve, rubber large, 3 pcs)



www.americanautowire.com 856-933-0801

**1990 JEEP YJ**  
**Rear Wiper Harness**  
**510807**  
*Classic Update Series*

92972911 Rev 0.0 8/12/2020

# 510807 Rear wiper dash harness installation instructions:

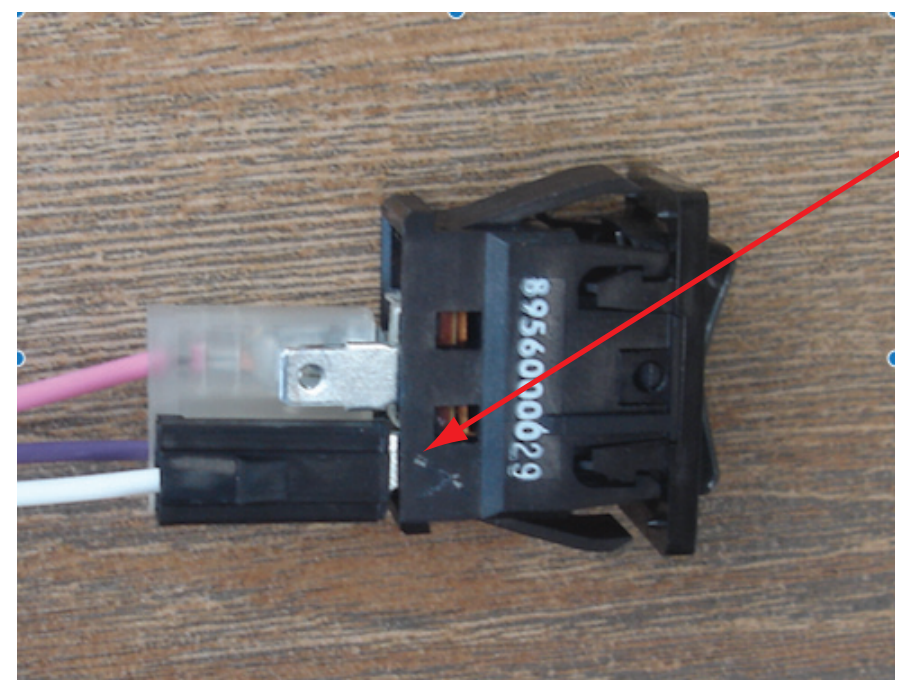
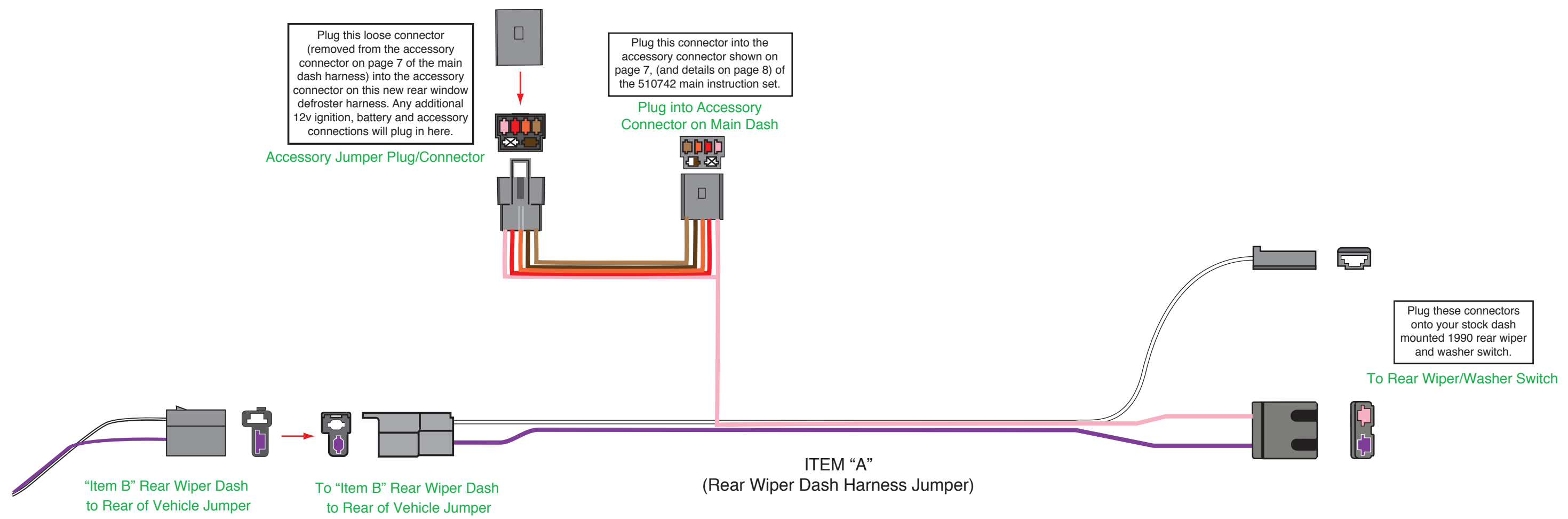

**NOTE:** Make sure you plug the connectors onto the rear wiper/washer switch as shown here)

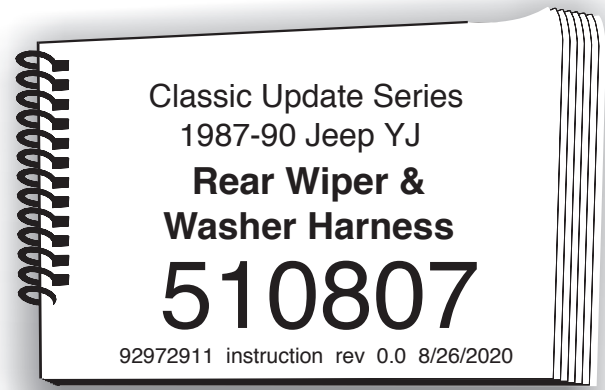
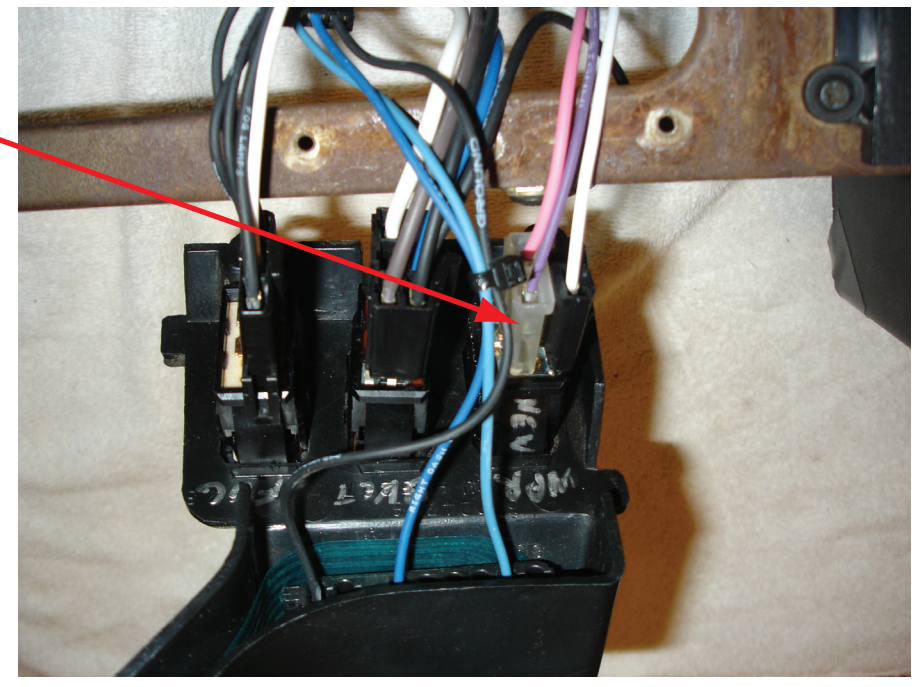



# 510807 Rear wiper dash to rear of vehicle harness installation instructions:

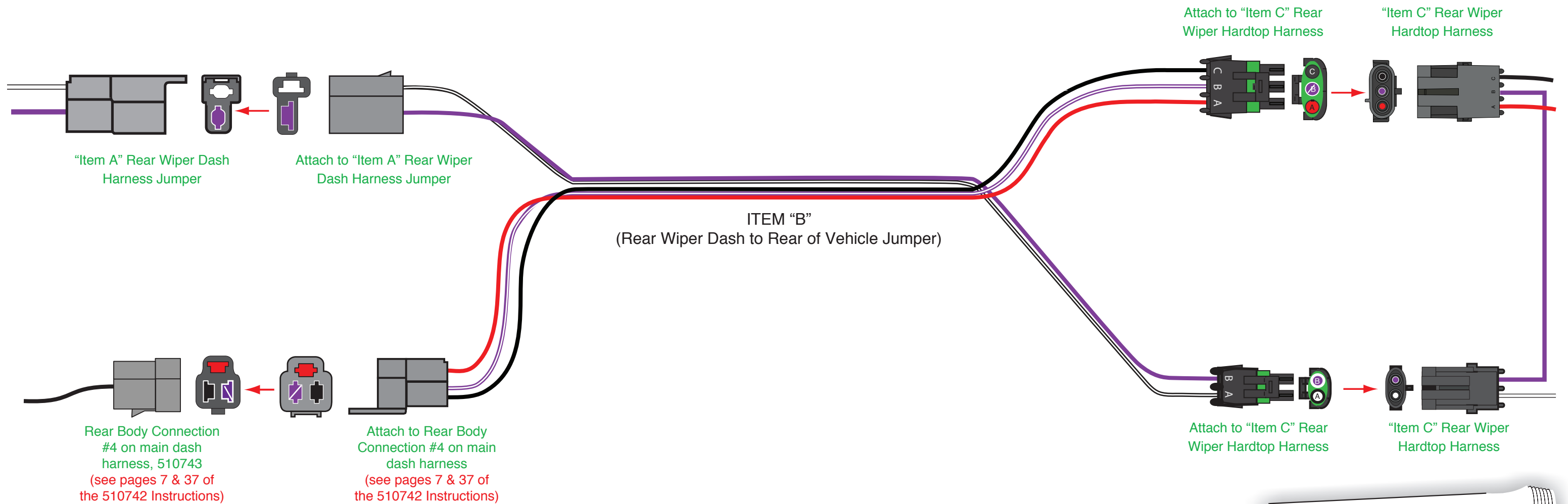

www.americanautowire.com 856-933-0801

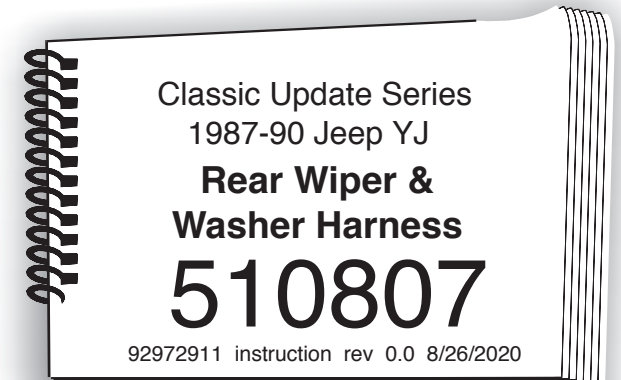

# 510807 Rear wiper hardtop harness installation instructions:

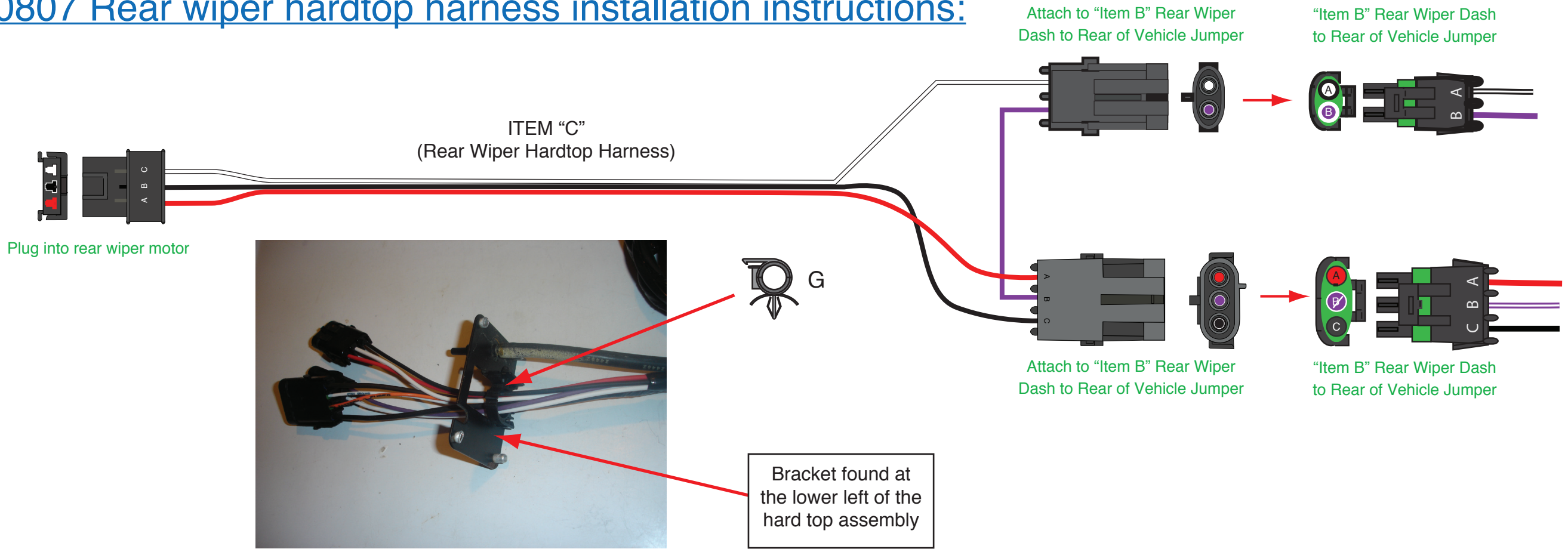

# 510807 Rear washer pump (under hood) installation instructions:

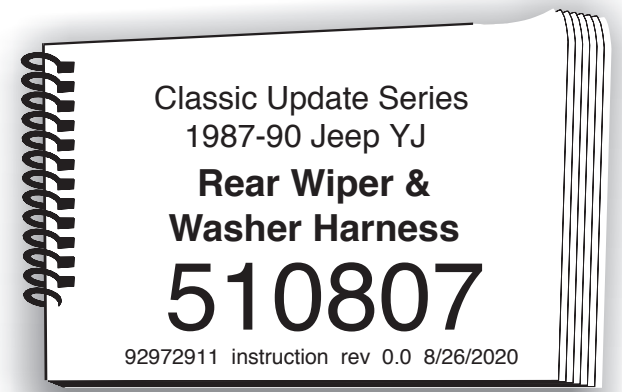
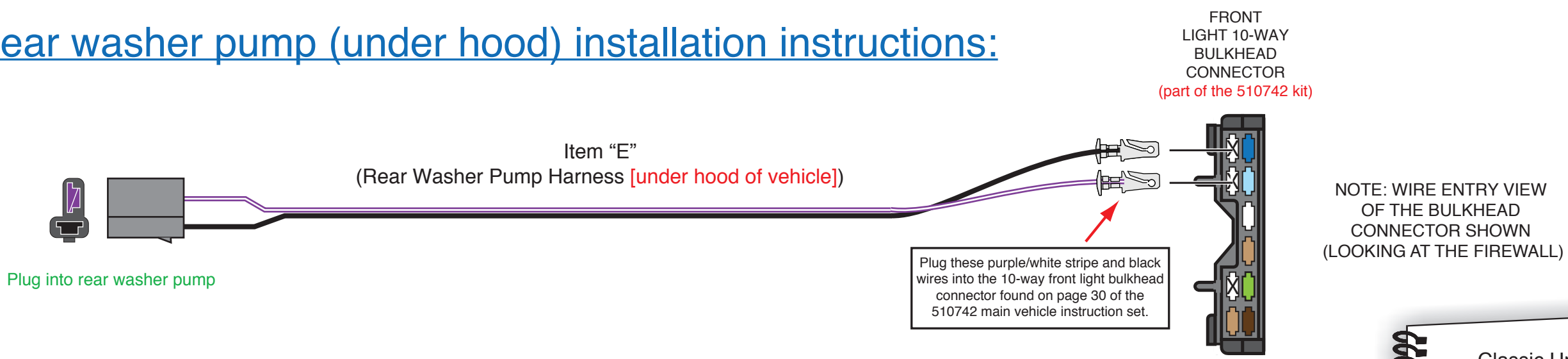

# 510807 Rear wiper dome light hardtop harness installation instructions:

**NOTE:** This hard top dome light harness will not be used if your vehicle has the rear defroster option and you have purchased the 510797 kit (available separately at an extra cost). You will use the dome light hard top harness found in that kit instead.

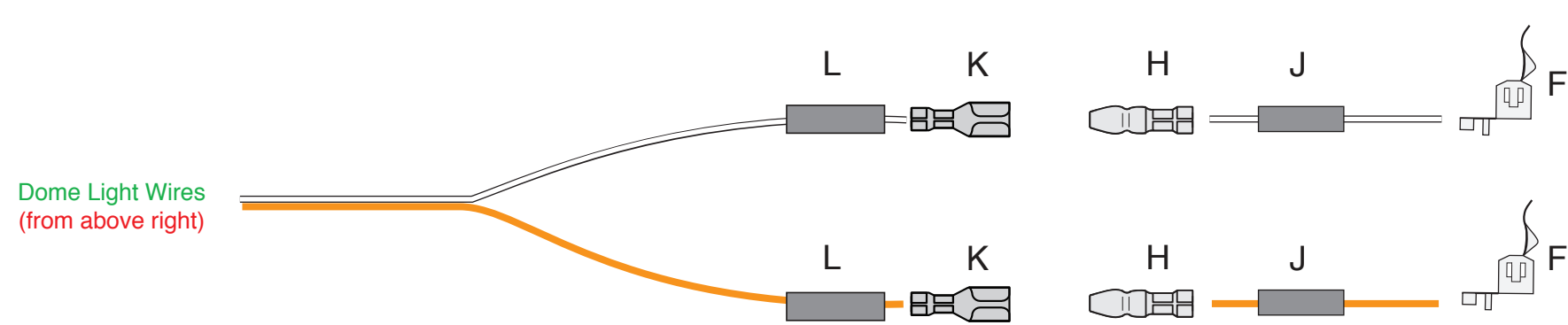
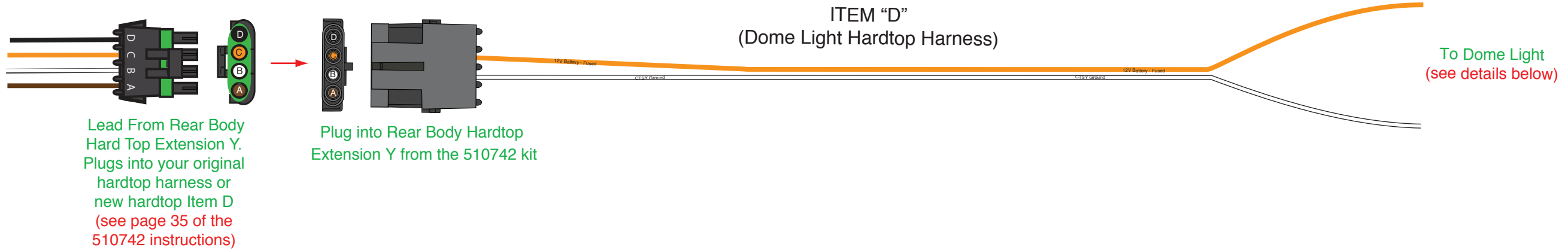

## Dome Light option A

**NOTE:** With this option, you will be creating a disconnect for your dome lamp assembly:

1. Route the orange and white wires to the dome lamp. Trim the wires to length, and slide sleeve L (larger) onto the orange and white wires. Crimp terminal K, then slide sleeve L up the wire to insulate terminal F
2. Take the remaining orange and white wire from step 1 and cut to length to make a short extension. Slide sleeve J (smaller) onto the orange and white wires, and crimp terminals H onto the wires. Slide sleeve J over the crimped area of terminal H to insulate it. Crimp terminal F onto the other end of the orange and white extension wires, then snap them into the dome lamp housing. (see below)
3. Plug H terminals from the extension into terminals K on the dome light wires from the main hard top harness to complete the dome lamp circuits.

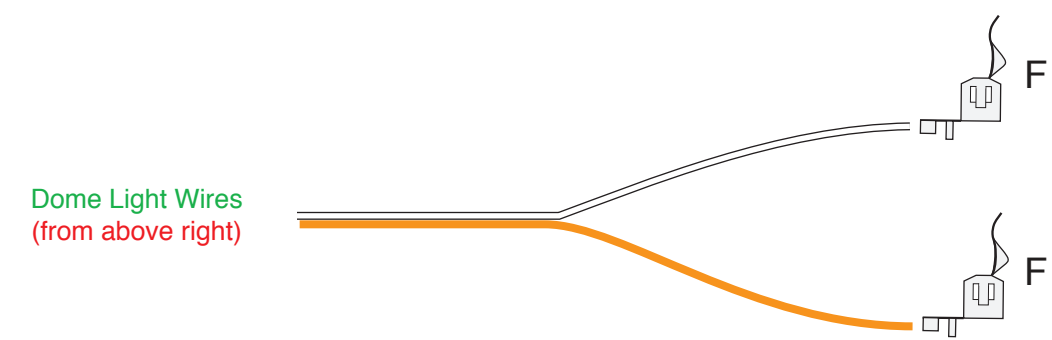

## Dome Light option B

**NOTE:** With this option, you will route the orange and white wires directly to your dome lamp housing, trim the wires to length and apply the original style terminals F directly onto the orange and white wires, then snap them into the dome lamp housing.

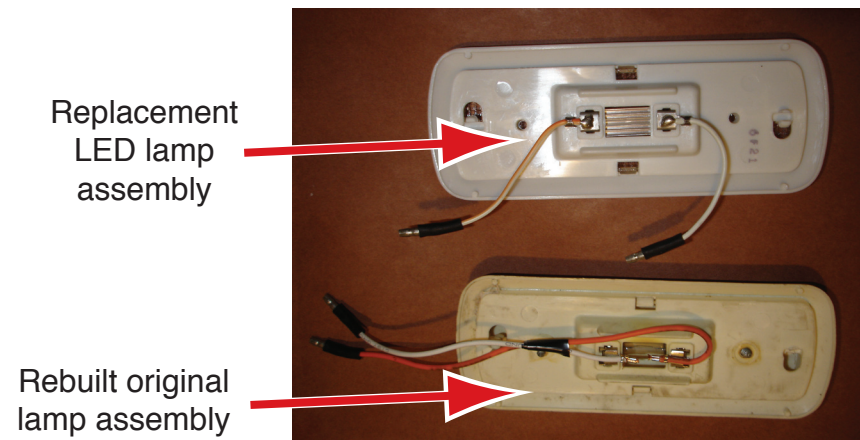

www.americanautowire.com 856-933-0801

Classic Update Series  
1987-90 Jeep YJ  
Rear Wiper &  
Washer Harness

510807

92972911 instruction rev 0.0 8/26/2020