

Classic Update Series

66-67 Ford Fairlane and 66-67 Mercury Comet

START HERE !

PLEASE READ THIS BEFORE STARTING INSTALLATION !

This wiring kit is designed for ease of installation. Please read the guidelines below, BEFORE STARTING your installation to guarantee a successful job. Use an appropriate crimping tool which folds the wings of the open barrel terminals down into the wire as shown below. ALL TERMINALS THAT YOU INSTALL SHOULD BE PROPERLY SOLDERED. Our factory crimped terminations are installed by GM approved five ton presses, and soldering these terminations is not necessary. AAW offers a great terminal crimping video entitled "Proper Crimping Video". It can be viewed by visiting YouTube. Type the following address into your web browser to go directly to the video: www.youtube.com/watch?v=8u_EkMsioMy.



PLEASE READ THESE HELPFUL INSTALLATION TIPS BEFORE GOING ANY FURTHER!

Prior to installing the Dash/Main harness in your vehicle, plug all of the fuses, flashers, (see a detailed photograph on page 14 of this instruction set) and Horn Relay into this harness.

AS THIS HARNESS IS DESIGNED FOR USE IN A MODIFIED VEHICLE REQUIRING A HIGHER RATE OF CHARGE, IT DOES NOT SUPPORT THE USE OF A STOCK (ORIGINAL) ALTERNATOR. IT IS DESIGNED FOR USE WITH AN INTERNALLY REGULATED GM "SI" STYLE OR SINGLE WIRE STYLE ALTERNATOR. ADAPTERS (WHICH ARE NOT INCLUDED WITH THIS KIT) THAT ARE AVAILABLE FROM SEVERAL SOURCES WILL BE NECESSARY TO USE ANY ALTERNATOR OTHER THAN A GM "SI" STYLE OR SINGLE WIRE STYLE UNIT.

STEP 1: DISCONNECT YOUR BATTERY:

Disconnect the battery before installing the wiring kit to prevent any accidental shorting caused by loose bare wire ends.

STEP 2: START INSTALLING KIT (see page 3):

This kit is broken down into individual steps that are identified by a letter printed on the instruction sheets visible through each bag. These letters are the order of operation for installing your kit. Start with bag letter G, then H, etc. The order of installation is shown below. You will use this main instruction sheet, 92970603, to complete the installation process of bag G. See page three of this instruction set and Fuse Block Mounting instruction sheet 92970684 to begin.

G - 510392 Dash Harness Kit
H - 510393 Gauge Cluster Kit
M - 510395 Rear Body Kit
N - 510394 Headlight Harness Kit
Z - 510476 Alternator and Main Connection Kit

STEP 3: RECONNECT YOUR BATTERY:

When you have completed the installation and are ready to reconnect the battery, make sure that the following electrical system grounds are in place:

- A. Battery is grounded to the ENGINE BLOCK.
- B. Battery is grounded to the frame.
- C. Engine block is grounded to the frame.
- D. Body is grounded to the frame.

STEP 4: CHECK ALL ELECTRICAL FUNCTIONS:

Any non-functioning items should be checked for proper installation. Any problems with your wiring and electrical circuit functions should be addressed to American Autowire Systems, Inc. as soon as possible to avoid any warranty problems.

If you have any questions concerning this or any of our products, please feel free to call us at 1-856-933-0801.

AMERICAN AUTOWIRE MAKES IT EASY !!

We carry many accessories for your 66-67 Ford Fairlane and 66-67 Mercury Comet

p/n 510585
OEM small terminal crimping
tool (18-14 gauge)



p/n 510586
OEM large terminal crimping
tool (12-8 gauge)



p/n 510587
Includes Both
terminal crimping tools

p/n 500918
Ford Duraspark Ignition Harness



p/n 500802
GM "SI" series to Ford "3G" int.
regulated alternator



www.americanautowire.com 856-933-0801

Classic Update Series
1966-67 Ford Fairlane
1966-67 Mercury Comet

510391

© COPYRIGHT 2004 American Autowire / Factory-Fit
Used with express permission of
American Autowire / Factory-Fit

92970603 Rev. 4.2 5/12/2020

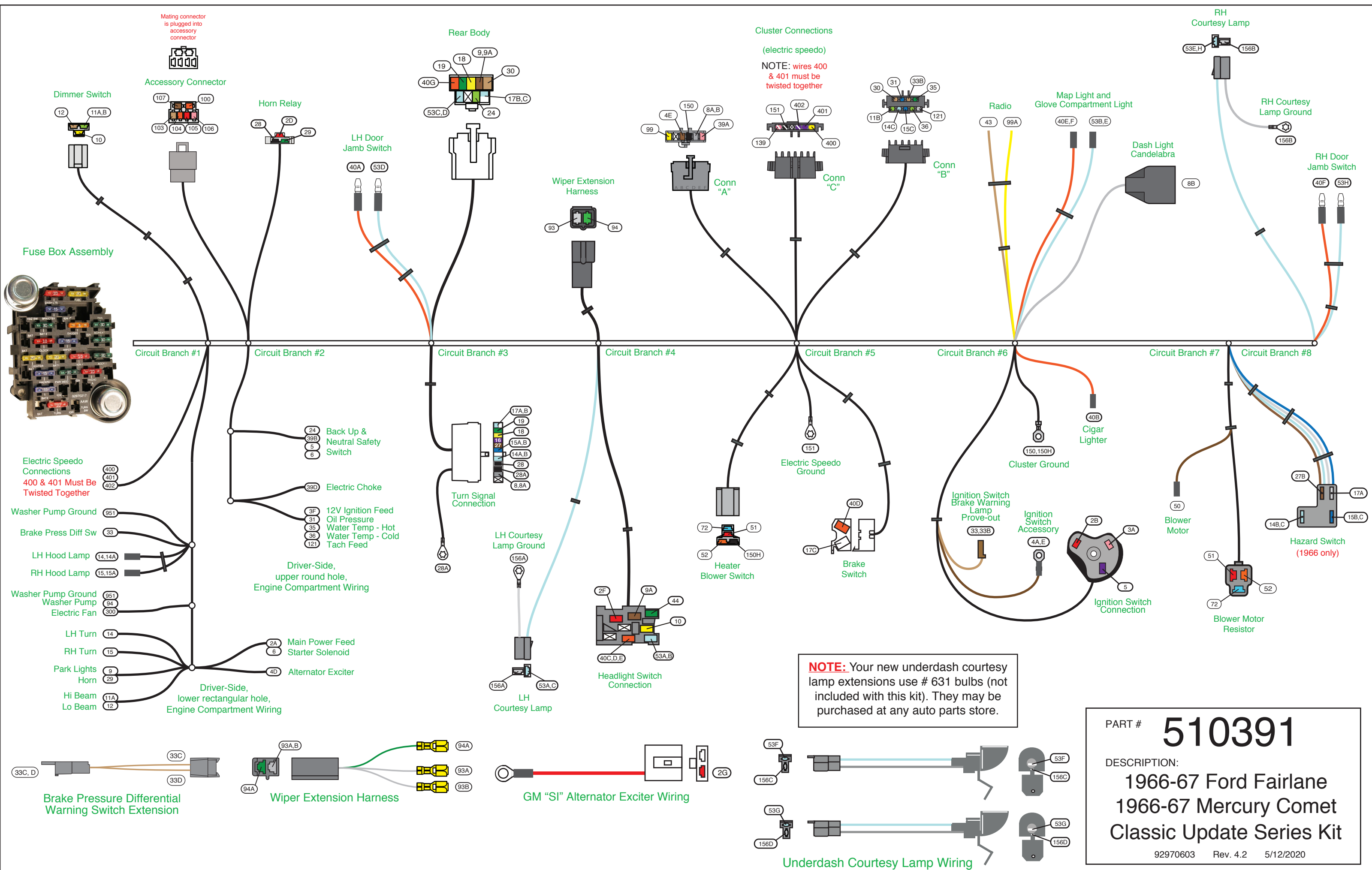

Cluster Connections
(electric speed)
NOTE: wires 400 & 401 must be twisted together

NOTE: Your new underdash courtesy lamp extensions use # 631 bulbs (not included with this kit). They may be purchased at any auto parts store.

PART # **510391**

DESCRIPTION:
1966-67 Ford Fairlane
1966-67 Mercury Comet
Classic Update Series Kit

92970603 Rev. 4.2 5/12/2020

Prior to installing the Main Dash Harness, plug all of the Fuses and Flashers in the Fuse Block (see page 14 for location of fuses and flashers). Install the Horn Relay to the Dash Harness **510392** (see Circuit Branch #2 for the Horn Relay location).

Main Dash Harness Installation Instructions

NOTE: Before installing the Main Dash Harness **510392**, you will have to reuse and install your existing factory Wiper System Wiring. We provide a 12V feed to the Wiper Switch and the Washer Switch, plus the ground wire for the Washer Pump, but you will need to reuse your original Wiper Wiring and Connectors.

For all **Fairlanes**, obtain the Wiper Extension Harness (see page 2) and the original Wiper System Wires. Remove the orange with white stripe wire from your original Wiper Switch 5-way connector (see Figure E on page 14) and plug in one of the white wires from the Wiper Extension Harness in that same location in the 5-way connector. This 5-way connector, with the original wires, will eventually plug onto your Wiper Switch. Install a connector **U** (see parts kit **510396**) on each remaining terminal of the Wiper Extension Harness. These two wires will eventually plug onto the Washer Switch.

For all **Comets** without Intermittent Wipers, obtain the Wiper Extension Harness (see page 2) and the original Wiper System wires. Remove the orange with white stripe wire and the white wire from your original Wiper Switch 7-way connector and plug in the two white wires from the Wiper Extension Harness where the two removed wires were located. Now remove the green with a black stripe wire from the same 7-way connector. Plug the remaining Dark Green wire from the Wiper Extension Harness into the same location in the 7-way connector. This 7-way connector will eventually plug onto your Wiper Switch.

Install the original Wiper System Wires and the Fuse Block (see the **Fuse Block Mounting Instructions 92970684**). You may wish to remove the zip ties from the Engine Compartment Wiring, when routing the wiring through the grommets.

Install two **S** clamps, found in the **510396** Parts Kit, by utilizing the original cross brace mounting bolts. The Instrument Panel harness routing will be similar to the original harness.

Now that the Fuse Block has been installed and the original wiper wires are in place, continue installing the Dash Harness, beginning with Circuit Branch 1.

Circuit Branch 1 – Under Dash Connections

Dimmer Switch Route this wiring branch to the Dimmer Switch and connect. Plug this connector onto the Dimmer Switch **500042**, and then attach the Dimmer Switch to the floor pan.

Wire #	Wire Color	Printing	Description
10	Yellow	DIMMER SW FEED	Feed from the Headlight Switch.
11A	Light Green	HEADLIGHT-HI BEAM	Feed to LH Headlight-High Beam
11B	Light Green	HI BEAM INDICATOR LIGHT	Feed to the Hi Beam Indicator Light.
12	Tan	HEADLIGHT-LOW BEAM	Feed to LH Headlight-Low Beam.

Circuit Branch 1 – Engine Compartment Connections (Wiring from the Rectangular Hole)

Aftermarket Electric Speedometer Connect to your Electric Speedometer per the manufacturers recommendations. Note that wires 400 and 401 must remain twisted together.

Wire #	Wire Color	Printing	Description
400	Yellow	VSS GROUND	Vehicle Speed Sensor Ground.
401	Purple	VSS SIGNAL	Vehicle Speed Sensor Signal.
402	Purple/White	VSS POWER	Vehicle Speed Sensor Power if using a 3 wire sender.

Washer Pump Ground Connect this wire to the Wiper Motor ground.

Wire #	Wire Color	Printing	Description
951	Black/White	no printing	Washer Pump ground to Wiper Motor.

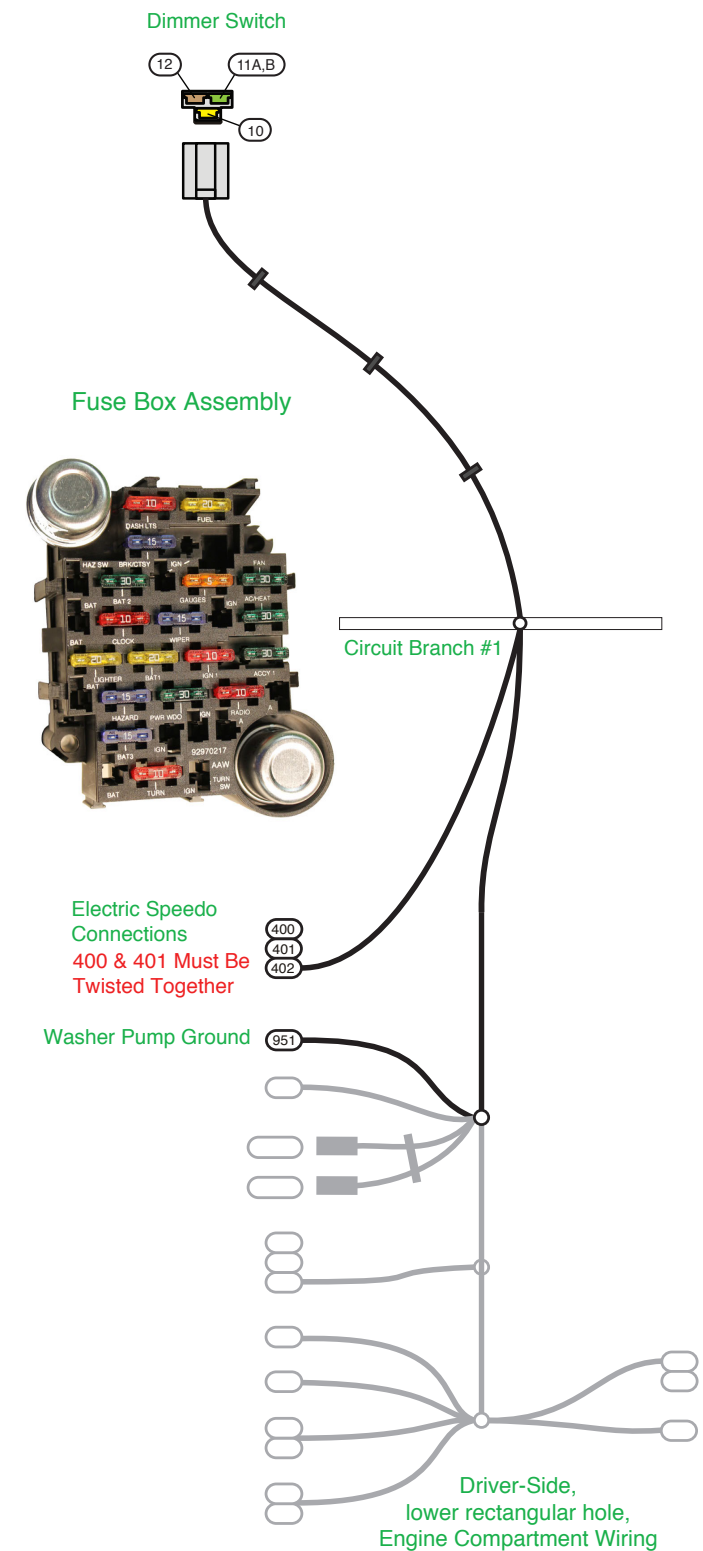

www.americanautowire.com 856-933-0801

PART # **510391**
 DESCRIPTION:
 1966-67 Ford Fairlane
 1966-67 Mercury Comet
 Classic Update Series Kit

92970603 Rev. 4.2 5/12/2020

NOTE: If you choose to upgrade your single reservoir Brake System to an upgraded dual reservoir Brake System, we have provided the circuits in the Dash Harness for a Brake Warning Light (Dash lamp and switch/switch connection not provided in kit).

Brake Pressure Differential Switch

(NOTE:) We have provided you with the connection to the original Ford brake warning switch, in the form of the Brake Pressure Differential Warning Switch Extension (see page 2). You will plug this extension onto wire 33, below.

Brake Pressure Differential Warning Switch Dash Harness Connection

Route this wire to the brake warning switch area near the master cylinder, cut to length, install terminal B, plug into connector E, then plug this wire into the Brake Pressure Differential Warning Switch Extension (see page 2), to complete your brake warning circuit (see Figure A on page 12).

Wire #	Wire Color	Printing	Description
33	Tan	BRAKE LIGHT/SWITCH	Brake Warning feed.

Hood Lamp Turn Signal Connection If your vehicle is equipped with the optional Hood mounted Turn Signal Lamps and Wiring, you will need to replace the original factory 2-way wiring connector that connects to the engine compartment wiring with two 1-way male bullet connectors. Remove the 2-way connector and crimp on terminal H and slide on sleeve J over each terminal (both can be found in Parts Kit 510396). You can now make the connection to the 1-way female bullet connectors in the Dash Harness. The original factory Ford LH Turn Signal wire is green/white, and the RH Turn Signal wire is white/blue.

Wire #	Wire Color	Printing	Description
14, 14A	Light Blue	LEFT FRONT TURN	Left Front Turn Signal.
15, 15A	Dark Blue	RIGHT FRONT TURN	Right Front Turn Signal

Washer Pump Route the Dark Green wire to the Washer Pump and connect. The Black/White wire will connect to the ground side of the Washer Pump.

Wire #	Wire Color	Printing	Description
94	Dark Green	no printing	Washer Pump feed.
951	Black/White	no printing	Washer Pump ground to Washer Motor.

Aftermarket Electric Fan This circuit is provided to feed the trigger wire of your Electric Fan Relay (not provided with this kit). See the Electric Fan Manufacturers recommendations for electrical hook up. NOTE: This is a keyed hot feed.

Wire #	Wire Color	Printing	Description
300	Orange	ELECTRIC FAN	12V Accessory feed to the trigger wire of the Electric Fan Relay.

Park/Turn Lamp & Socket Assemblies NOTE: You will need to reuse the original Park/Turn Signal Lamp & Socket Assemblies, but will have to replace each 2-way bullet connector with a 2-way AAW connector (see figure A on page 12). Be sure that the Park/Turn Signal Lamp pigtail is routed and retained, per the original factory routing, before replacing the connectors. For both LH and RH Park/Turn Lamp & Socket Assemblies, remove the old 2-way molded bullet connectors, and install terminals W to each wire and install the wires in the 2-way connector V (all supplied in kit 510396) as shown in figure A on Page 12. The original Ford Left Front Turn wire is green/white and the Park Light wire is black/yellow. The original Ford Right Front Turn wire is white/blue and the Park Light wire is black/yellow.

Left Hand & Right Hand Park/Turn Lamp Connectors Select the brown Park Light wire (9), route the wire close to the 2-way connector V that was just added to the LH Park/Turn Signal Lamp & Socket Assembly, cut to length, take the cut off portion, double them together in terminal C and install into connector T (see page 12 Figure A). Be sure to align the AAW brown Park Light wire with the original Park Light wire. Route the remaining brown wire close to the 2-way connector that was just added to the RH Park/Turn Signal Lamp & Socket Assembly. Crimp on terminal B, and install into another connector T.

Select the light blue Left Front Turn wire (14), route this wire to the same connector T where wire 9 is located. Crimp on terminal B and install in that connector T (see page 12 Figure A). Now make the connection to the LH Park/Turn Lamp & Socket Assembly.

Select the Right Front Turn wire (15) and route it to the 2-way connector V that was added to the RH Park/Turn Signal Lamp & Socket Assembly. Cut to length, crimp on terminal B and install into connector T (see page 12 Figure A) where the brown park light wire is already located. Now make the connection to the RH Park/Turn Lamp & Socket Assembly. Be sure to align the AAW Park Light wire (brown) with the Ford Park Light wire (black/yellow), the AAW Left Turn wire (Lt Blue) with the Ford Left Turn wire (green/white), and the AAW Right Turn wire (DK Blue) with the Ford Right Turn wire (white/blue).

Wire #	Wire Color	Printing	Description
9	Brown	PARK LIGHTS	Park Light feed.
14	Lt Blue	LEFT FRONT TURN	Left Turn Signal feed.
15	DK Blue	RIGHT FRONT TURN	Right Turn Signal feed.

Horn Connection Route wire (29) to the LH Horn and cut to length, double with the wire that was just cut, crimp on terminal C and insert into connector N and attach to the LH Horn (see Figure A on page 12). Route the loose wire to the RH Horn and crimp on terminal B and insert into connector N and attach to the RH Horn. All of the terminals and connectors will be found in kit 510396.

Wire #	Wire Color	Printing	Description
29	Dark Green	HORN	Horn feed.

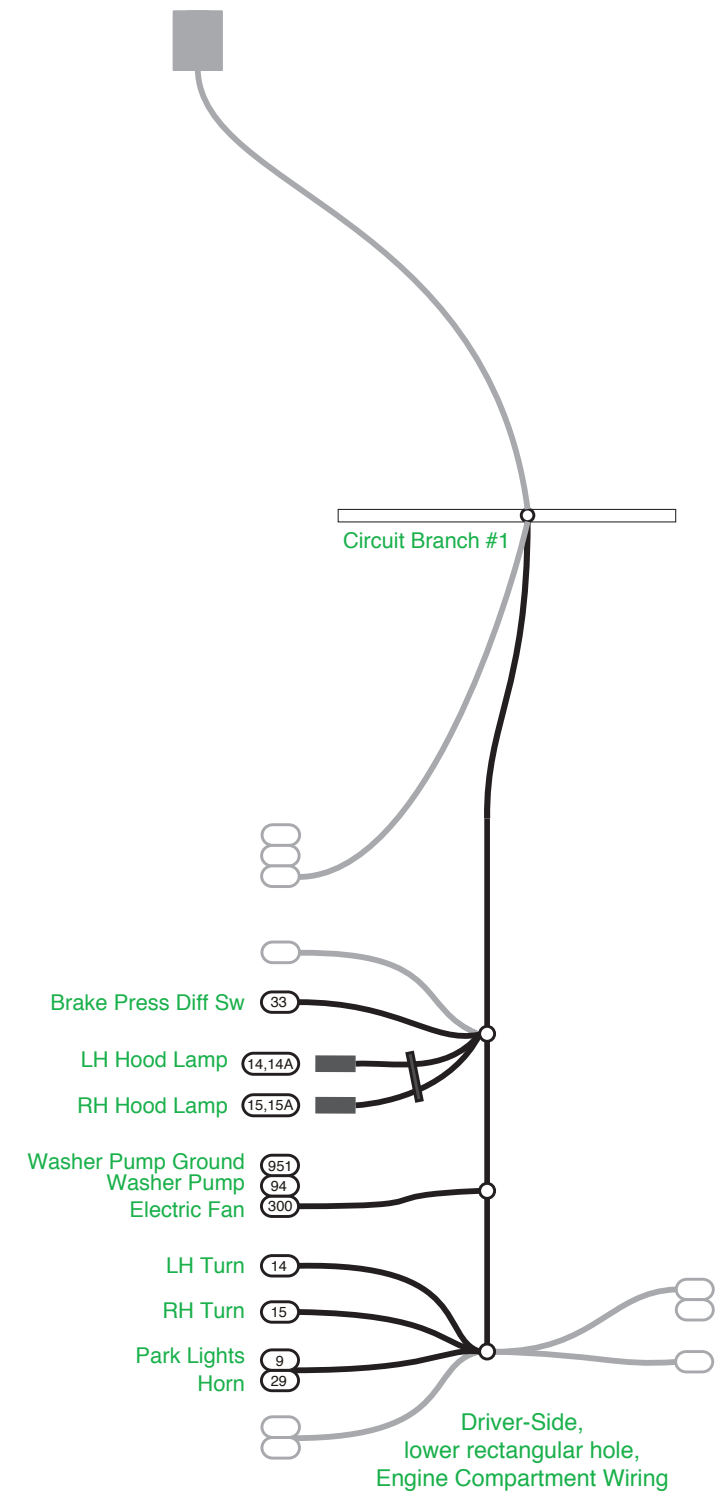

www.americanautowire.com 856-933-0801

PART # **510391**

DESCRIPTION:
1966-67 Ford Fairlane
1966-67 Mercury Comet
Classic Update Series Kit

92970603 Rev. 4.2 5/12/2020

LH and RH Headlight Extension Harnesses Obtain the Headlight Extension Harnesses **510394 (Bag N)** and connect to your LH and RH Headlights. Route the Dash Harness Connector and Ring Terminal through the Radiator Core Support access hole.

Headlights Select the light green Headlight High Beam wire (11A) and the tan Headlight Low Beam wire (12). Route these wires to the LH Headlight Extension Harness, cut each to length, take each of the cutoff portions, double each of them together with their original wires, crimp on terminal **C** to each pair of wires, and install each terminal into connector **Z** found in kit **510396** (see **Figure A on page 12**). Be sure to align the tan wire 12 with the Headlight Extension Harness tan wire and the light green wire 11A to the Headlight light green wire. Now plug this connector to the LH Headlight Extension Harness. Attach the black ground wire, with the ring terminal, from the LH Headlight Extension Harness to a good Radiator Core Support ground. Take the remaining light green and tan wires and route them to the RH Headlight Extension Harness. Cut each to length, crimp on terminal **B** to each one, and install into another connector **Z**. Align the wire colors as before. Plug this connector to the RH Headlight Extension Harness. Attach the black ground wire, with the ring terminal, from the RH Headlight Extension Harness to a good Radiator Core Support ground.

Wire #	Wire Color	Printing	Description
11A	Lt Green	HEADLIGHT-HI BEAM	High Beam feed to the LH headlight.
12	Tan	HEADLIGHT-LOW BEAM	Low Beam feed to the LH headlight.

Starter Relay Connections Route wires 2A and 6 to the Starter Motor Relay.

Main Power Feed to the Fuse Block Route wire 2A from the Dash Harness to the MegaFuse supplied with the 510476 kit and cut to length, apply ring terminal, and shrink tubing and connect as shown on (see page 13, figure C).

Wire #	Wire Color	Printing	Description
2A	Red	12V BATTERY	Main power feed.

Start Circuit Route wire 6 to the Starter Relay and cut to length. Install sleeve **D** and crimp on terminal **K** (see parts kit **510396**). Connect to the Starter Solenoid S stud (see page 12, figure A).

Wire #	Wire Color	Printing	Description
6	Purple	STARTER SOLENOID-S	Start circuit.

Alternator Output Circuit Use the 6ga red wire, MegaFuse, ring terminals, and shrink tubing from the 510476 kit. Route 6ga red wire from MegaFuse to the alternator and cut to length, apply ring terminal and connect as shown on (see page 13 figure C).

Wire #	Wire Color	Printing	Description
2	Red	no printing	Alternator output wire. (Part of 510476 kit)

Alternator Exciter Wire The wire 4D is the exciter wire for your Alternator/Voltage Regulator. If you are using a one wire Alternator, this wire will not be used and should be capped off as it is "hot" in the ignition "on" position. If you are using an Alternator that requires an exciter wire to turn on the regulator, this wire must be connected to the "switched or 12V ignition" terminal on your Voltage Regulator or Alternator according to the manufacturers specifications for the type of Alternator/Voltage Regulator that is being used. An inline diode or resistor may be necessary to eliminate "run on" after being switched off. AAW recommends a GEN 3 Internally Regulated or one wire alternator. If you are using a GM "SI" alternator, obtain the GM "SI" Alternator Exciter Wiring Harness (see page 2). Attach the ring terminal end of wire 2G to the Alternator Battery stud (see page 13 Figure C). Route the 4D wire in the Dash Harness to the 2-way connector, which is part of the same Exciter Wiring Harness. Crimp on terminal **B** to wire 4D and insert into the open cavity of the 2-way connector (see page 13, figure C). Now plug the 2-way connector into the "SI" alternator.

Wire #	Wire Color	Printing	Description
2G	Red	12V BATTERY	Battery wire for the GM "SI" Alternator Exciter Wiring Harness.
4D	Brown	ALTERNATOR IGN	Alternator Exciter wire.

Circuit Branch 2 – Under Dash Connections

Accessory Connector Use the provided 6-way empty connector, which is attached to the 6-way connector on the Dash Harness, and terminals **B** or **C** (see kit **510396**) to add power leads (not provided) for the following systems:

Wire #	Wire Color	Printing	Fuse Block	Fuse Rating	Description
100	Orange	no printing	BAT3	15A	Battery feed for Audio systems.
103	Tan	FUEL PUMP	FUEL	20A	Ignition feed for Electric Fuel Pump.
104	Orange	POWER SEATS	BAT 2	30A	Battery feed for Power Seats.
105	Red	POWER LOCKS	BAT1	20A	Battery feed for Power Locks.
106	Pink	POWER WINDOWS	PWR WDO	30A	Ignition feed for Power Windows.
107	Brown	no printing	ACCY 1	30A	Accessory feed for Cruise Control or options

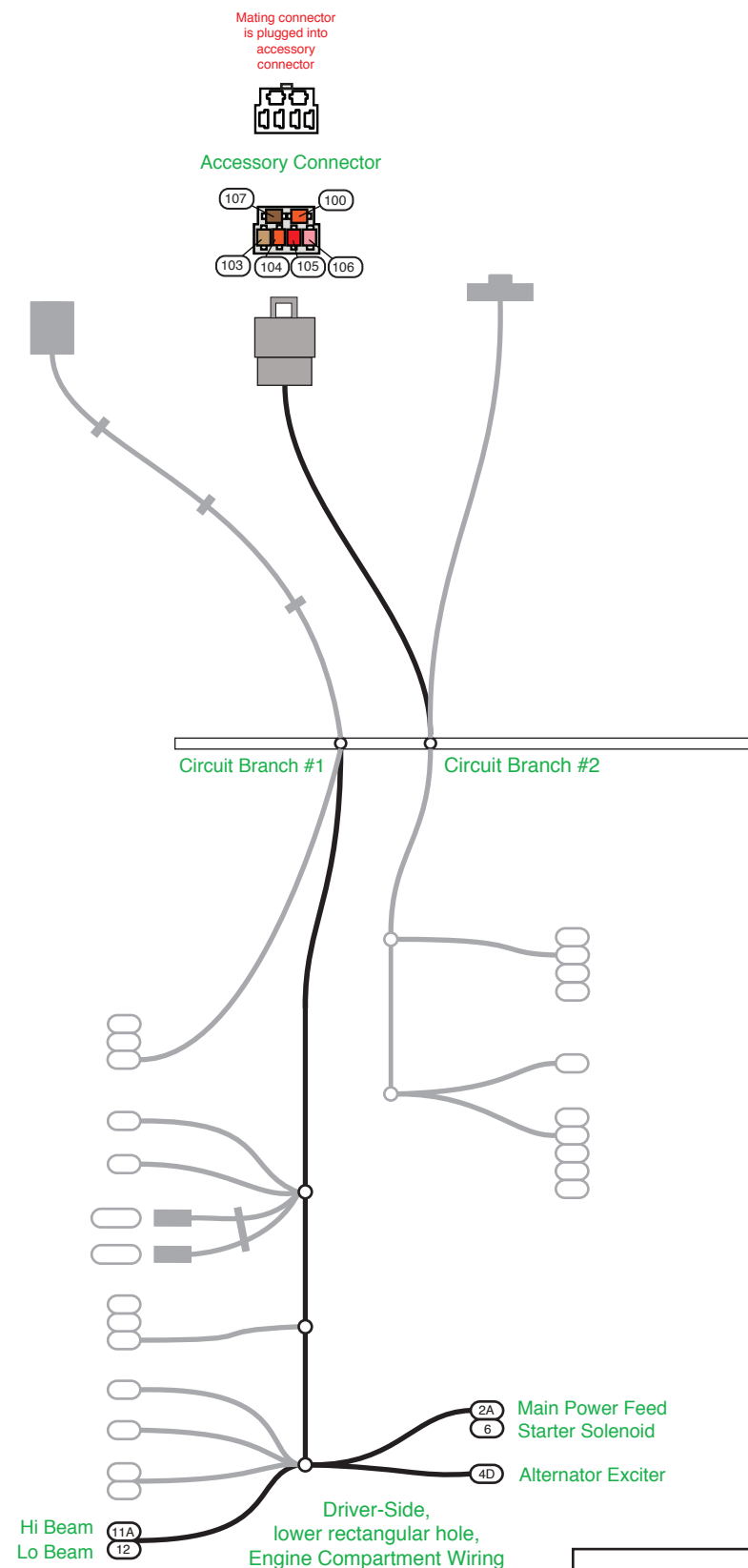

www.americanautowire.com 856-933-0801

PART # **510391**

DESCRIPTION:
1966-67 Ford Fairlane
1966-67 Mercury Comet
Classic Update Series Kit

92970603 Rev. 4.2 5/12/2020

Horn Relay Connector If you haven't already, now plug the Horn Relay (found in the [510353](#) Fuse kit) into this connector.

Wire #	Wire Color	Printing	Description
2D	Red	12V BATTERY	12V Battery feed to the Horn Relay.
28	Black	HORN RELAY GROUND	Relay ground circuit (to Steering Column).
29	Dark Green	HORN	Feed to the Horn.

Circuit Branch 2 – Engine Compartment Connections (Wiring from the Round Hole)

The Back-up and Neutral Safety Switches Route circuits 24 and 39B to the Back-up Lamp Switch and connect. If you have an Automatic Transmission, route circuits 5 and 6 to the Neutral Safety Switch and connect. If you have a Manual Transmission, connect wire 5 to wire 6. **Note: If wire 5 and wire 6 are not connected your starter solenoid will not engage and your engine will not crank.** A typical connection for the Neutral Safety/Back-up Switch can be found on [page 13, Figure D](#).

Wire #	Wire Color	Printing	Description
5	Purple	NEUTRAL SAFETY SWITCH	Start feed from the Ignition Switch to the Neutral Safety Switch or to wire 6.
6	Purple	STARTER SOLENOID-S	Start circuit from the Neutral Safety Switch or wire 5 to the Starter Solenoid.
24	Lt Green	BACK UP LT SW	Feed from the Back-up Lamp Switch to the Back-up Lamps.
39B	Pink	12V IGNITION	12V feed to the Back-up Lamp Switch.

Ignition Feed This is your 12V switched power source for the distributor/coil. This can be connected directly to the "Bat" terminal on a typical HEI Distributor, to a Ballast Resistor for a point's type Distributor, or to be used as the ignition power source for an Aftermarket Ignition Module such as an MSD or "Dura Spark" module. See the installation instructions for the type of Distributor you are using for specific connection requirements. If you are using a GM style HEI distributor, terminal **C** and connector **P** (see [Parts Kit 510396](#)) have been provided to make that connection (see [page 13 figure B](#) for some examples).

Wire #	Wire Color	Printing	Description
3F	Pink	IGNITION FEED	Switched 12V Feed for the ignition.

Engine Sensors and Electric Choke Route circuit 31 to the single post Oil Pressure Sending Unit (all engines).

If you have a single post Water Temperature Sending Unit (6 cylinder Fairlanes and all Comets), route circuit 35 to the Water Temperature Sending Unit (see [page 13, figure B](#)), cut to length, install terminal **B** or **M** (install sleeve **J** first if using **M**), plug into connector **N** (if using terminal **B**), and connect to the Water Temperature Sending Unit.

If you have a double post Water Temperature Sending Unit (most 8 cylinder Fairlanes), route circuits 35 (Hot) and 36 (Cold) to the Water Temperature Sending Unit (see [page 13, figure B](#)). Slide the sleeve over the terminal and connect to the Water Temperature Sending Unit. See parts kit [510396](#) for connectors and terminals. The original Ford Hot wire was Red with a White Stripe, and the Cold wire was White with a Green Stripe.

Route the 39D wire to the Electric Choke (if equipped) and connect, no mating connectors or terminals have been provided for the Electric Choke connection.

Wire #	Wire Color	Printing	Description
31	Dark Blue	OIL PRESSURE SENDER	Oil Pressure Sending unit.
35	Dark Green	WATER TEMP SENDER	Hot Water Temperature (all models).
36	Light Green	no printing	Cold Water Temperature (used on most 8 cylinder Fairlanes only).
39D	Tan	ELECTRIC CHOKE	On carbureted vehicles, connect to the Electric Choke.

Tachometer **NOTE: This Kit will not support the use of an original factory tachometer (see the Warning Page).** However, this can be connected directly to the Tachometer terminal on a typical HEI Distributor, to the negative side of the Ignition Coil, or a Tachometer connection in an aftermarket Ignition Module such as an MSD module. If you are using a GM style HEI Distributor, terminal **B** and connector **Q** ([Parts Kit 510396](#)) have been provided to make that connection (see [page 13, figure B](#)).

Wire #	Wire Color	Printing	Description
121	White	COIL --> TACH	Tachometer feed wire.

Circuit Branch 3 – Under Dash Connections

Left Hand Door Jamb Switch Connection Route the two bullet terminals through the Door Jamb switch hole from behind, and connect to the Door Jamb Switch [92964258](#) which is included in kit [510396](#). Polarity does not matter. Attach the Door Jamb Switch in the original location.

Wire #	Wire Color	Printing	Description
40A	Orange	12V BATTERY-FUSED	12V Fused Battery Feed.
53D	Lt Blue	12V CTSY SW	Feed to the LH Courtesy Light.

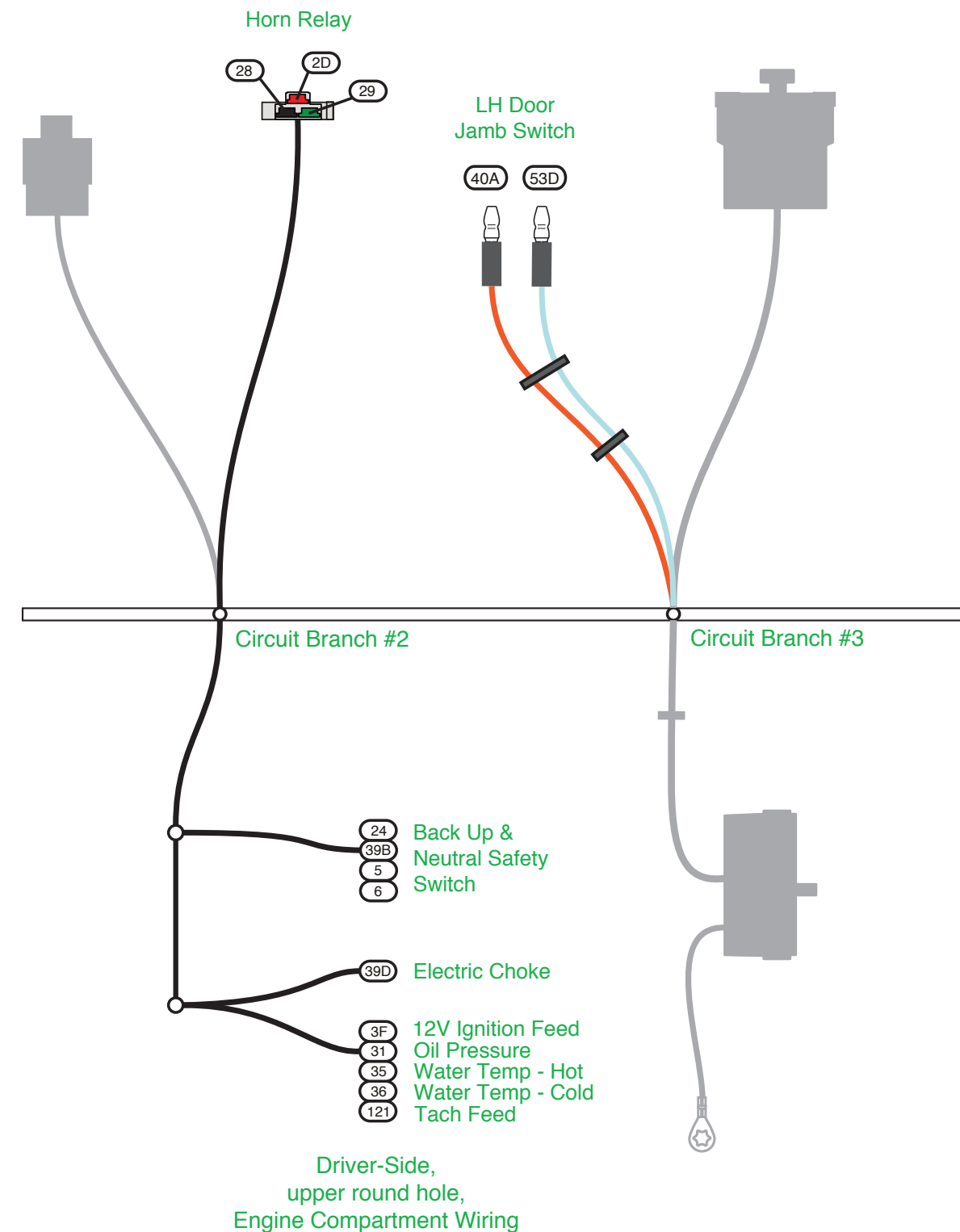

www.americanautowire.com 856-933-0801

PART # **510391**
 DESCRIPTION:
 1966-67 Ford Fairlane
 1966-67 Mercury Comet
 Classic Update Series Kit

92970603 Rev. 4.2 5/12/2020

Rear Body Harness Connection This connector will plug to the Rear Body Harness 510395. Specific connections are addressed in that kit. The Rear Body Harness will route along the driver's sill the same as the original Ford Body Harness routing. Be sure to attach the wiring in the original routing clips.

Wire #	Wire Color	Printing	Description
9	Brown	PARK LIGHTS	Feed to the Front Park Lights.
9A	Brown	REAR RUNNING LIGHTS	Feed for the License Light and Rear Park Lights.
17B	Light Blue	THIRD BRAKE LIGHT	Feed for an aftermarket Third Brake Light.
17C	White	BRAKE SW	Brake Light Switch Feed to the Rear Body Harness.
18	Yellow	LEFT REAR TURN	Feed to the Left Rear Stop and Turn Light.
19	Dark Green	RIGHT REAR TURN	Feed to the Right Rear Stop and Turn Light.
24	Light Green	BACK UP LT SW	Feed from the Back-up Light Switch to the Back-up Lights.
30	Tan	GAS GAUGE	Fuel Tank Sender.
40G	Orange	12V BATTERY-FUSED	12V Feed for the Trunk Light or aftermarket LED Rear Lights.
53C, 53D	Light Blue	12V CTSY SW	Feed to the Dome Light.

Turn Signal Switch Connector Plug into the Steering Column Turn Signal Switch connector. If you are using a stock Ford Steering Column on your vehicle, refer to **Diagram 'A'** and **'Table A'** on page 11 for the proper mating directions. This Dash Harness is designed to function with a GM style turn signal switch. Our connector mates to a 3-7/8 inch long plug used on 1969-1974 GM, IDIDIT, and many other aftermarket steering columns. Starting from 1975 on up, the GM switch changed and began using a 4-1/4 inch connector. That connector is from the same family and uses the same terminals. By using the supplied mating connector and terminals located in the loose piece kit **bag G** (see 510391 inside bag) it is easy to adapt any steering column to this Dash Harness. The different functions of the wires in the Dash Harness connectors are as follows:

Wire #	Wire Color	Printing	Description
8, 8A	Gray	DASH LIGHTS	Feed to Auto Trans Gear Selector Indicator Light (PRNDL).
14A	Light Blue	LEFT FRONT TURN	Feed to LH Front Turn Signal Light.
14B	Light Blue	LEFT FRONT TURN	LH Turn Signal Feed from the Hazard Switch.
15A	Dark Blue	RIGHT FRONT TURN	Feed to RH Front Turn Signal Light.
15B	Dark Blue	RIGHT FRONT TURN	RH Turn Signal Feed from the Hazard Switch.
16	Purple	TURN SWITCH FEED	Turn Signal Feed from the Turn Signal Flasher.
17A	White	BRAKE SW	Brake Switch Feed from the Hazard Switch.
17B	LT Blue	THIRD BRAKE LIGHT	12V feed to the optional Third Brake Light.
18	Yellow	LEFT REAR TURN	Feed to LH Rear Turn Signal Light.
19	Dark Green	RIGHT REAR TURN	Feed to RH Rear Turn Signal Light.
27	Brown	TURN SW- HAZARD	Hazard Feed to the Steering Column from the Hazard Flasher.
28	Black	HORN RELAY GROUND	Horn Relay ground to Horn Switch.
28A	Black	HORN RELAY GROUND	Horn Switch to ground.

Circuit Branch 4 – Under Dash Connections

Wiper Extension Harness Connector Since your original Wiper wires are now connected to the Wiper Extension Harness, you can now connect this 2-way connector to the Wiper Extension Harness.

Wire #	Wire Color	Printing	Description
93	White	WIPER FEED	12V fused feed for the Wiper/Washer Switch(s).
94	Dark Green	no printing	Washer Pump Feed from the Washer Switch.

Left Hand Courtesy Lamp Connector Plug into one Under Dash Courtesy Lamp Wiring Harness, from **bag G** (as shown on page 2), to complete this circuit, and attach to the lower Instrument Panel.

Wire #	Wire Color	Printing	Description
53A, 53C	Light Blue	12V CTSY SW	12V Switched feed to the Left Hand Courtesy Light.
156A	White	CTSY GROUND	LH Courtesy Lamp ground. Attach this ring terminal to a good ground.

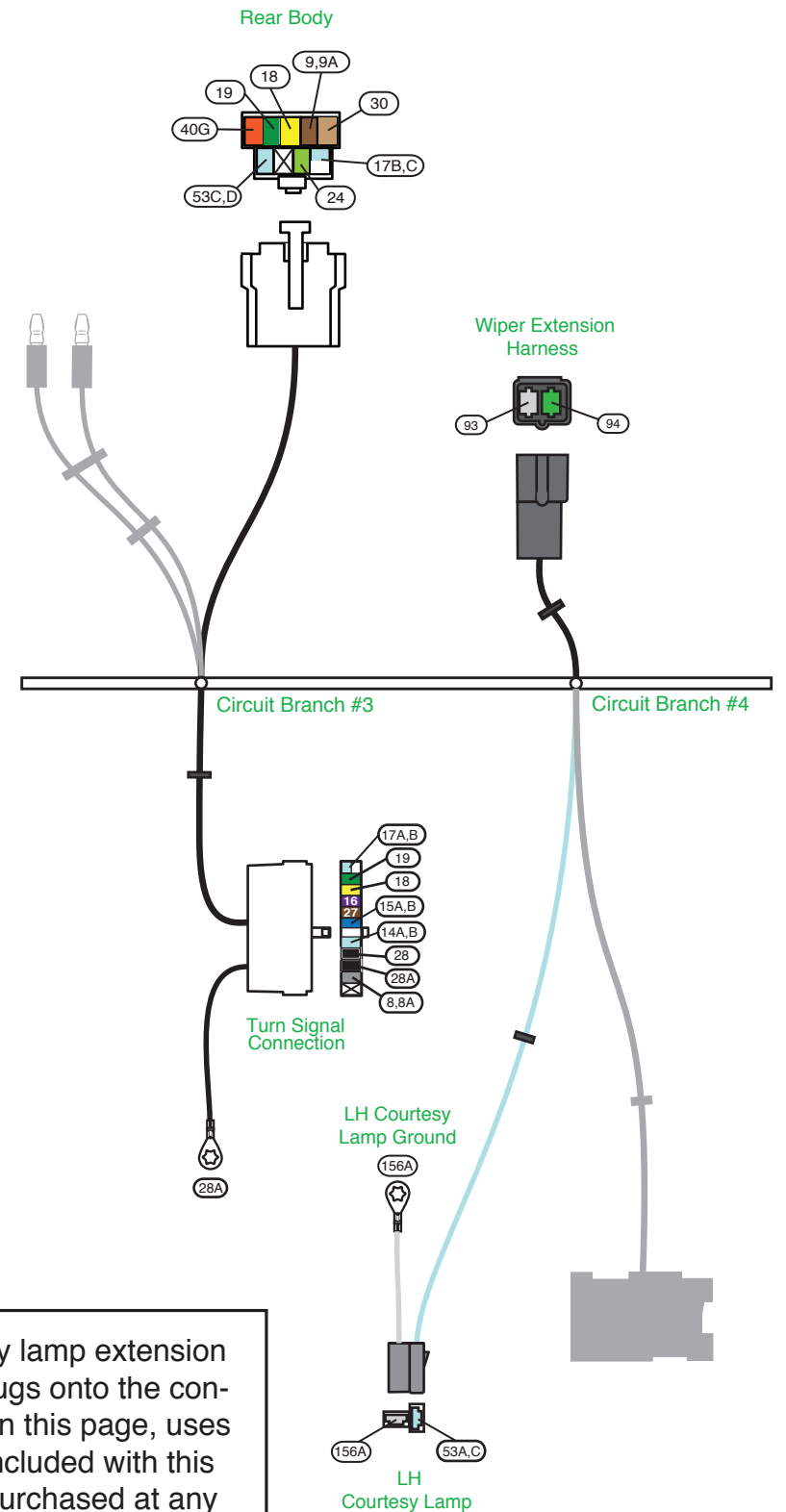

NOTE: The courtesy lamp extension from page 2, that plugs onto the connector at branch 4 on this page, uses a # 631 bulb (not included with this kit). They may be purchased at any auto parts store.



www.americanautowire.com 856-933-0801

PART # **510391**

DESCRIPTION:
1966-67 Ford Fairlane
1966-67 Mercury Comet
Classic Update Series Kit

92970603 Rev. 4.2 5/12/2020

Headlight Switch Connector Plug this connector to the Headlight Switch **510264** and then install the switch.

Wire #	Wire Color	Printing	Description
2F	Red	12V BATTERY	Un-fused 12V Battery feed from the Fuse Block.
9A	Brown	REAR RUNNING LIGHTS	Feed to the Rear Tail Lights and the License Light.
10	Yellow	DIMMER SW FEED	Feed to the Dimmer Switch for the Headlights.
40C	Orange	12V BATTERY-FUSED	Fused 12V battery feed from the Fuse Block.
40D	Orange	BRAKE SW	Feed to the Brake Switch.
40E	Orange	12V BATTERY-FUSED	Feed to the Map Light or the Glove Box Light.
44	Dark Green	no printing	Feed to the Fuse Block for the Dash Lights.
53A	Light Blue	12V CTSY SW	12V Switched feed to the Left Hand Courtesy Light.
53B	Light Blue	12V CTSY SW	12V Switched feed to the Map Light.

Circuit Branch 5 – Under Dash Connections

Instrument Cluster Connections These connections will plug into the Cluster Connector Kit **510393**. Instructions are included in that kit.

Cluster Connector “A”

Wire #	Wire Color	Printing	Description
4E	Brown	no printing	Cluster 12V Accessory Feed.
8A, B	Gray	DASH LIGHTS	Fused 12V from the Fuse Block for the Cluster Illumination Lights.
39A	Pink	12V IGNITION	Fused 12V Ignition Feed.
99	Yellow	CLOCK BAT	Fused 12V Battery Feed for the Clock.
150	Black	GROUND	Cluster ground.

Cluster Connector “B”

Wire #	Wire Color	Printing	Description
11B	Light Green	HI BEAM INDICATOR LIGHT	Feed To the High Beam Indicator Light.
14C	Light Blue	LEFT DASH IND	Feed for the Left Turn Signal Indicator Light.
15C	Dark Blue	RIGHT DASH IND	Feed for the Right Turn Signal Indicator Light.
30	Tan	GAS GAUGE	Fuel Gauge Signal from the Fuel Tank Sending Unit.
31	Dark Blue	OIL PRESSURE SENDER	Oil Pressure Sender Signal from the Engine.
33B	Tan	BRAKE LIGHT/SWITCH	Brake Warning Light Feed.
35	Dark Green	WATER TEMP SENDER	Hot Water Temperature Sender Signal from the Engine.
36	Light Green	no printing	Cold Water Temperature Sender Signal from the Engine.
121	White	COIL --> TACH	Feed for an Aftermarket Tachometer (see the Warning Sheet).

Cluster Connector “C” This connector contains the circuits for an Aftermarket Electric Speedometer. **Wires “400” and “401” must remain twisted together.**

Wire #	Wire Color	Printing	Description
139	Pink/White	SPEEDO POWER	Fused 12V feed for the Electric Speedometer.
151	Black/White	SPEEDO GROUND	Electric Speedometer ground.
400	Yellow	VSS GROUND	Vehicle Speed Sensor ground.
401	Purple	VSS SIGNAL	Vehicle Speed Sensor signal.
402	Purple/White	VSS POWER	Vehicle Speed Sensor power.

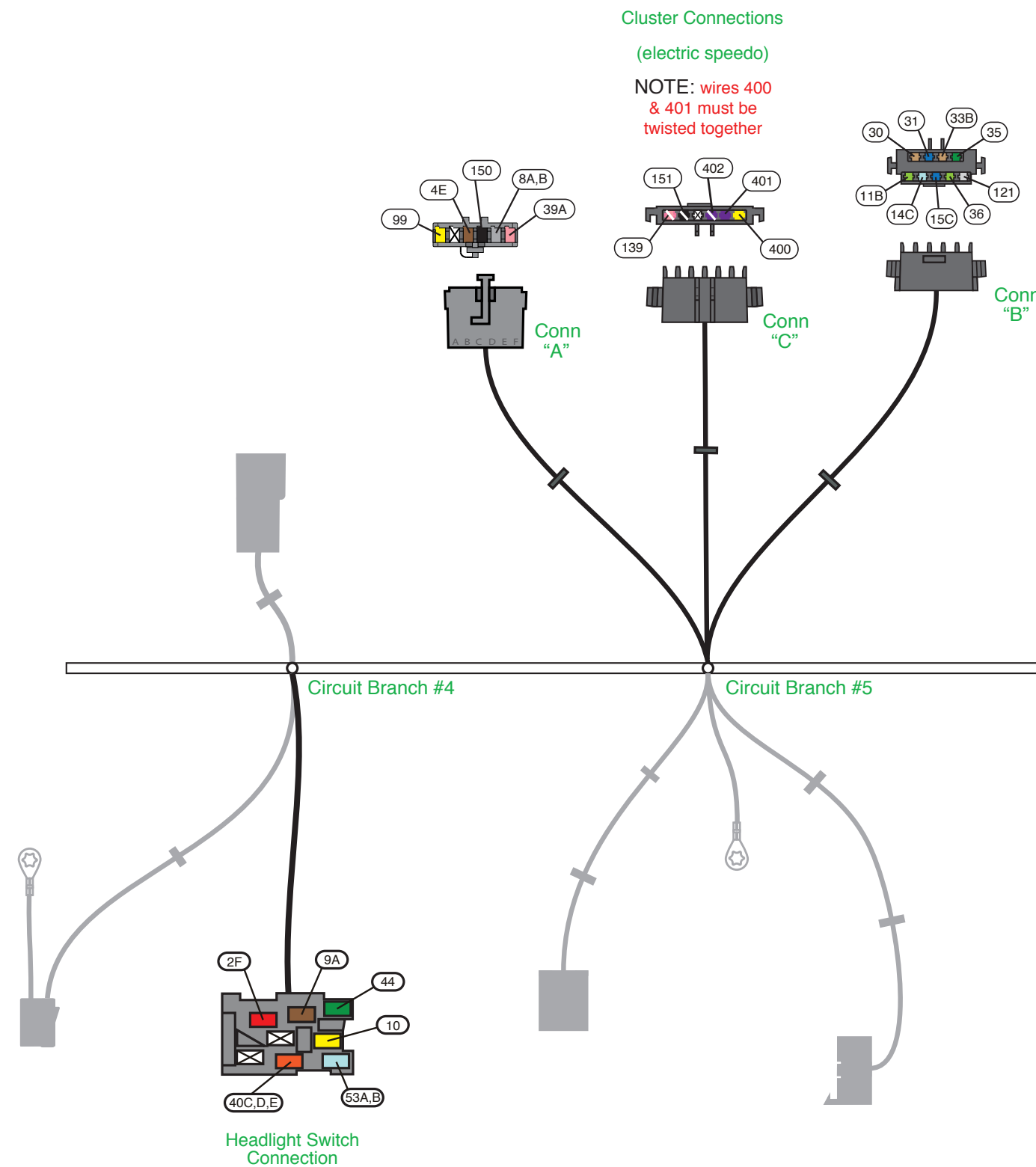

www.americanautowire.com 856-933-0801

PART # **510391**
 DESCRIPTION:
 1966-67 Ford Fairlane
 1966-67 Mercury Comet
 Classic Update Series Kit
 92970603 Rev. 4.2 5/12/2020

Aftermarket Electric Speedometer Ground Attach this wire to a good body ground. **NOTE: Do not attach this ring terminal with the "150, 150H" ground ring terminal in Circuit Branch #6.**

Wire #	Wire Color	Printing	Description
151	Black/White	Speedo Ground	Ground for an Aftermarket Electric Speedometer.

Heater Blower Switch Connector Connect this 4-way connector to the Heater Blower Switch.

Wire #	Wire Color	Printing	Description
51	Red	no printing	Heater Blower Switch Low Speed.
52	Orange	no printing	Heater Blower Switch High Speed.
72	Light Blue	no printing	Heater Blower Switch Medium Speed.
150H	Black	GROUND	Heater Blower Switch Ground.

Brake Switch (Stop Light) Connector Plug this connector to the Brake Light Switch which is mounted to the Brake Pedal Assembly.

Wire #	Wire Color	Printing	Description
17C	White	BRAKE SW	12V input from Brake Switch to Turn Signal Switch for Rear Brake Lights.
40D	Orange	BRAKE SW	Fused 12V Battery Feed from the Fuse Block.

Circuit Branch 6 – Under Dash Connection

Radio These circuits are provided for your Radio.

Wire #	Wire Color	Printing	Description
43	Tan	RADIO	12V Fused Accessory Feed for the Radio "On/Off" power.
99A	Yellow	RADIO BAT	12V Fused Battery Feed for the Radio Memory.

Map and Glove Compartment Connectors These connectors are provided for your optional Glove Box Light, Map Light, or Comet Door Courtesy Lights.

Wire #	Wire Color	Printing	Description
40E, F	Orange	12V BATTERY-FUSED	Battery Feed for the Glove Box, Map, or Comet Door Courtesy Lights. (Mates to dk green/yellow stripe wire).
53B, E	Light Blue	12V CTSY SW	Switched Feed for the Map or Comet Door Courtesy Lights. (Mates to black/lt blue stripe wire).

Dash Light Candelabra Attach the Ash Tray Light, Radio Illumination Light, Clock Light, Tachometer Light, or Auto Transmission Floor Shifter Dial Indicator Light to this candelabra connector. Note: If needed, male bullet terminals **A** and sleeves **D** have been provided to replace your original terminals. **They can be found in the 510396 Parts Kit.**

Wire #	Wire Color	Printing	Description
8B	Gray	DASH LIGHTS	Various Dash Light Feeds.

Cigar Lighter Connector Plug this connector to the Cigar Lighter.

Wire #	Wire Color	Printing	Description
40B	Orange	no printing	Fused 12V Battery Feed to the Cigar Lighter.

Ignition Switch Connector Plug this connector to the Ignition Switch **510053**.

Wire #	Wire Color	Printing	Description
2B	Red	12V BATTERY	12V Un-Fused Battery Feed from the Fuse Block.
3A	Pink	IGNITION FEED	Ignition Feed to the Fuse Block.
5	Purple	NEUTRAL SAFETY SWITCH	Start Feed to the Neutral Safety Switch or to Wire 6.

Ignition Switch Accessory Ring Terminal Attach this ring terminal to the Ignition Switch after the Ignition Switch Connector is plugged in. Use the nut to securely fasten the ring terminal to the Ignition Switch threaded stud. **NOTE: Do not over tighten.**

Wire #	Wire Color	Printing	Description
4A	Brown	IGNITION SW ACCY	12V Accessory Feed to the Fuse Block.
4E	Brown	no printing	12V Accessory Feed to the Cluster.

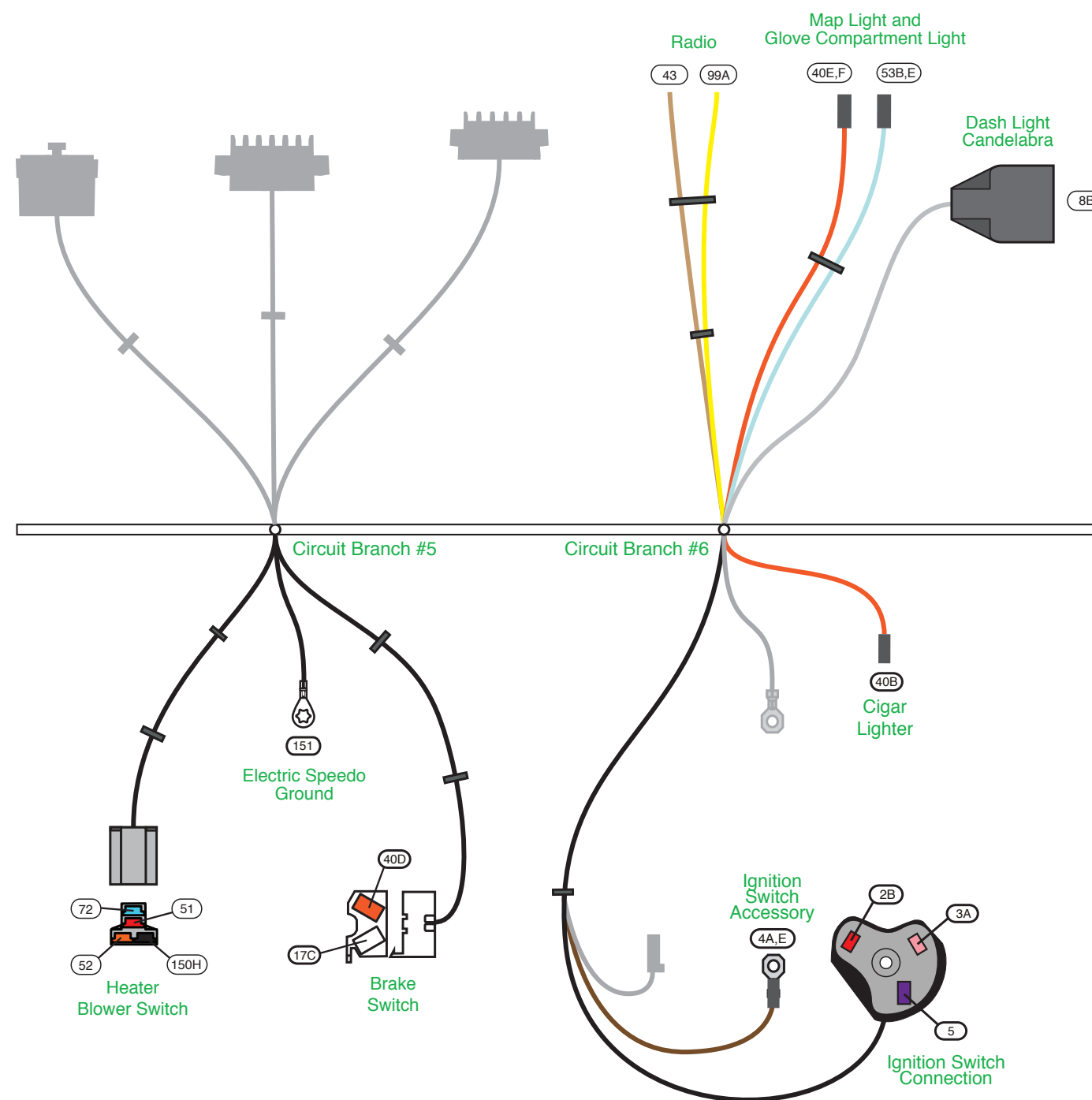

**American
Autowire**

www.americanautowire.com 856-933-0801

PART # **510391**

DESCRIPTION:

1966-67 Ford Fairlane
1966-67 Mercury Comet
Classic Update Series Kit

92970603 Rev. 4.2 5/12/2020

Ignition Switch Brake Warning Lamp Prove-out Connector Connect this to the Ignition Switch after the Ignition Switch Accessory Ring Terminal is attached. This connector plugs onto the blade terminal which is located on the side of the Ignition Switch. This wire provides the bulb check ground for the Brake Warning Lamp circuit when the Ignition Switch is in the "Start" position. Now install the switch.

Wire #	Wire Color	Printing	Description
33, 33B	Tan	BRAKE LIGHT/SWITCH	Brake Warning Lamp Bulb Check during Crank.

Ground Lead Attach this wire to a good body ground. **NOTE: Do not attach this ring terminal with the 151 ground wire in Circuit Branch #5.**

Wire #	Wire Color	Printing	Description
150	Black	GROUND	Cluster ground.
150H	Black	GROUND	Blower Switch Ground.

Circuit Branch 7 – Under Dash Connections

Blower Motor Connector Connect to the Blower Motor Pigtail Wire which has the male bullet (or main power feed "IN" on an aftermarket system). There is another Pigtail Wire from the Blower Motor which will connect to the Blower Motor Resistor. This wire has a female Blade Terminal.

Wire #	Wire Color	Printing	Description
50	Brown	HEATER/AC FEED	Fused 12V Blower Motor Feed. (This wire is your "key on" power feed wire for any aftermarket heat or A.C system as well)

Blower Motor Resistor Connector Plug this connector onto the Blower Motor Resistor

Wire #	Wire Color	Printing	Description
51	Red	no printing	Blower Motor Low Speed.
52	Orange	no printing	Blower Motor High Speed.
72	Light Blue	no printing	Blower Motor Medium Speed.

Hazard Switch Connector Plug this connector to the Hazard Switch on 1966 vehicles. If needed, new Hazard Switches are available from various Aftermarket Suppliers. For 1967 vehicles, the Hazard Switch is integral to the Steering Column and this connection will not be made.

Wire #	Wire Color	Printing	Description
14B	Light Blue	LEFT FRONT TURN	Feed to the Left Turn Signal.
14C	Light Blue	LEFT DASH IND	Feed to the Left Turn Signal Indicator in the Cluster.
15B	Dark Blue	RIGHT FRONT TURN	Feed to the Right Turn Signal.
15C	Dark Blue	RIGHT DASH IND	Feed to the Right Turn Signal Indicator in the Cluster.
17A	White	BRAKE SW	Hazard Feed to the Brake Lights.
27B	Brown	TURN SW-HAZARD	Emergency Flasher Feed to the Hazard Switch.

Circuit Branch 8 – Under Dash Connections

Right Hand Courtesy Lamp Connector Plug into one Under Dash Courtesy Lamp Wiring Harness, from bag G (as shown on page 2), to complete this circuit, and attach to the Lower Instrument Panel.

Wire #	Wire Color	Printing	Description
53E, 53H	Light Blue	12V CTSY SW	12V Switched Feed to the Right Hand Courtesy Lamp.
156B	White	CTSY GROUND	RH Courtesy Lamp ground. Attach this ring terminal to a good ground.

Right Hand Door Jamb Switch Connection Route the two bullet terminals through the Door Jamb Switch hole from behind, and connect to the Door Jamb Switch 92964258 which is included in kit 510396. Polarity does not matter. Attach the Door Jamb Switch in the original location.

Wire #	Wire Color	Printing	Description
40F	Orange	12V BATTERY-FUSED	12V Fused Battery feed.
53H	Light Blue	12V CTSY SW	Feed to the RH Courtesy Light.

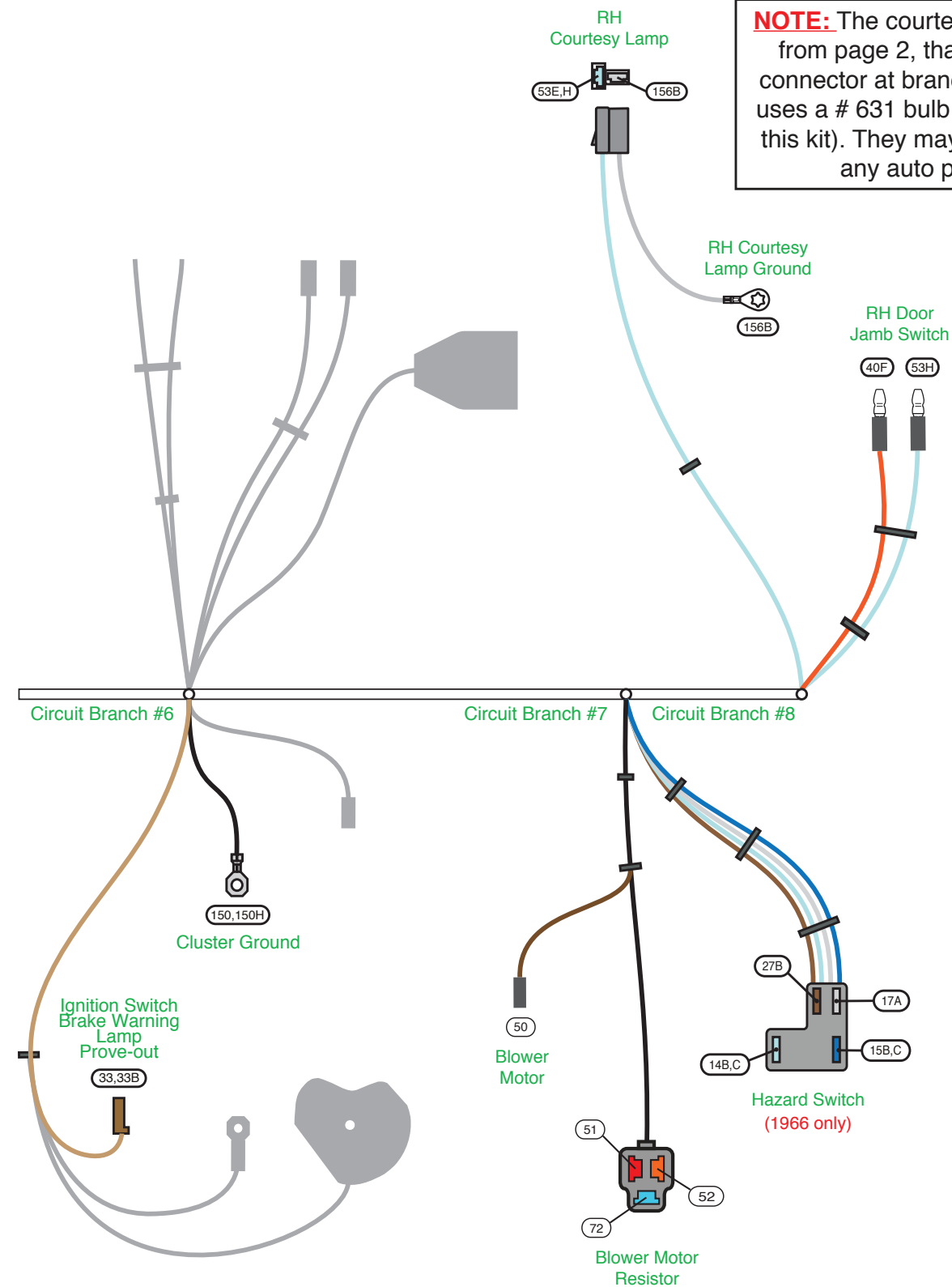

NOTE: The courtesy lamp extension from page 2, that plugs onto the connector at branch 8 on this page, uses a # 631 bulb (not included with this kit). They may be purchased at any auto parts store.



www.americanautowire.com 856-933-0801

PART # **510391**
 DESCRIPTION:
 1966-67 Ford Fairlane
 1966-67 Mercury Comet
 Classic Update Series Kit
 92970603 Rev. 4.2 5/12/2020

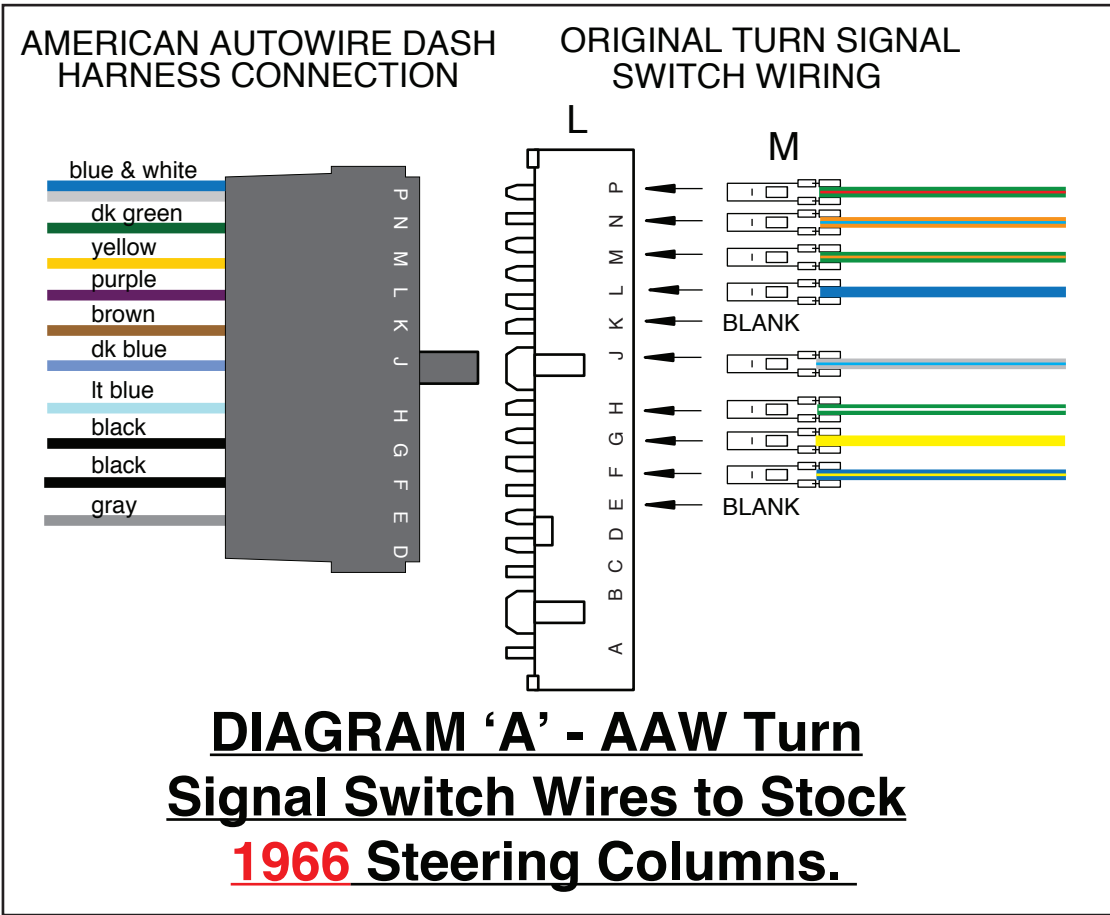

“Table A”

AAW Turn Signal Switch wires to stock 1966-1967 Ford Turn Signal Switch

AAW Wire #	AAW Wire Color	AAW Wire Printing	Connector Cavity	Ford Wire Color
17A,B	Blue & White	Brake SW	P	Green with Red Stripe (1966) or Green (1967)
19	Dark Green	Right Rear Turn	N	Orange with Blue Stripe
18	Yellow	Left Rear Turn	M	Green with Orange Stripe
16	Purple	Turn Switch Feed	L	Blue
27	Brown	Turn SW - Hazard	K	White with Red Stripe (1967 only)
15A,B	Dark Blue	Right Front Turn	J	White with Blue Stripe
14A,B	Light Blue	Left Front Turn	H	Green with White Stripe
28	Black	Horn Relay Ground	G	Yellow
28A	Black	Horn Relay Ground	F	Blue with Yellow Stripe
8A,B	Gray	Dash Lights	E	Blue with Red Stripe (1967 only)
	None	None	D	None

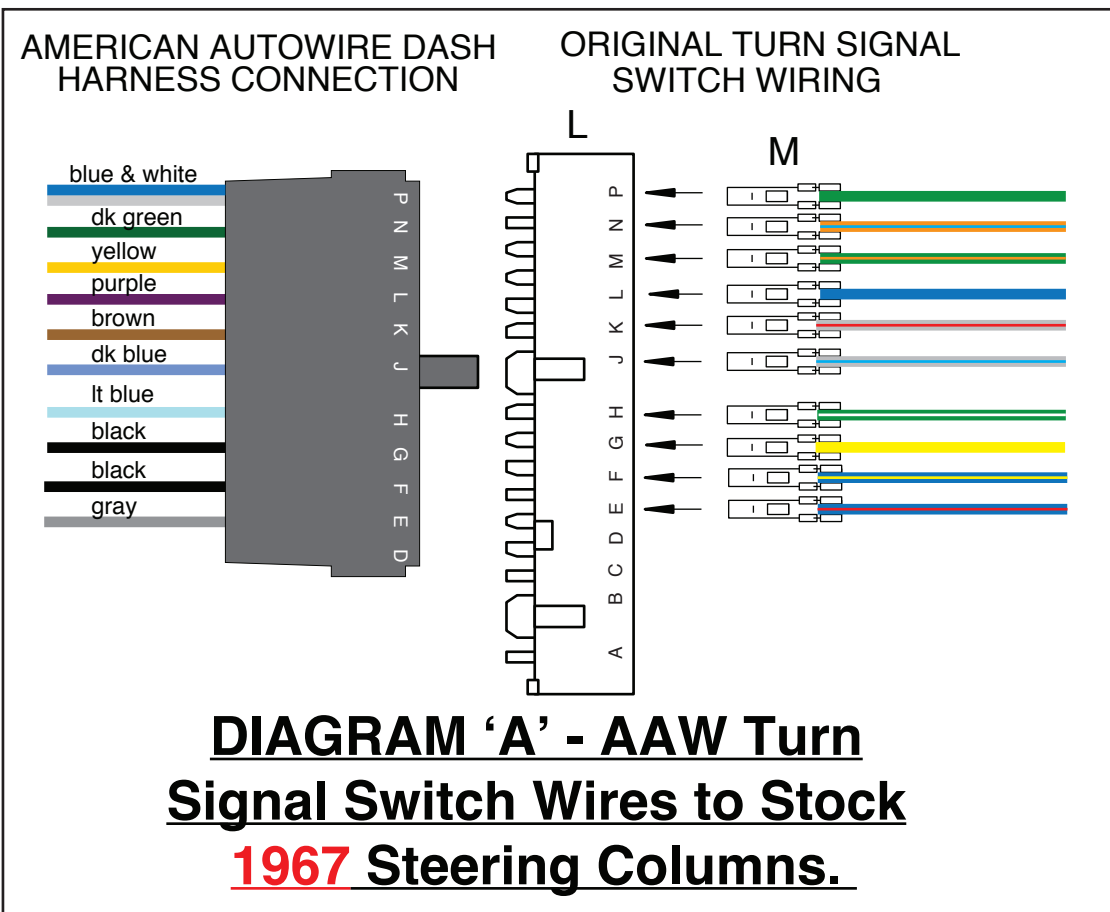

NOTE: For these vehicles, the Steering Column Horn Button switched 12V power to the Horns. The AAW design switches ground through the Steering Column Horn Button, which grounds a Horn Relay that will then switch power to the Horns. Therefore, you will have to align the AAW 28A Black wire (connector cavity F) to the Ford Blue with a Yellow Stripe wire. Be sure to connect the ring terminal end of this AAW Black wire to a good ground.



www.americanautowire.com 856-933-0801

PART # **510391**

DESCRIPTION:
 1966-67 Ford Fairlane
 1966-67 Mercury Comet
 Classic Update Series Kit

92970603 Rev. 4.2 5/12/2020

510394 Headlight Extension Harness

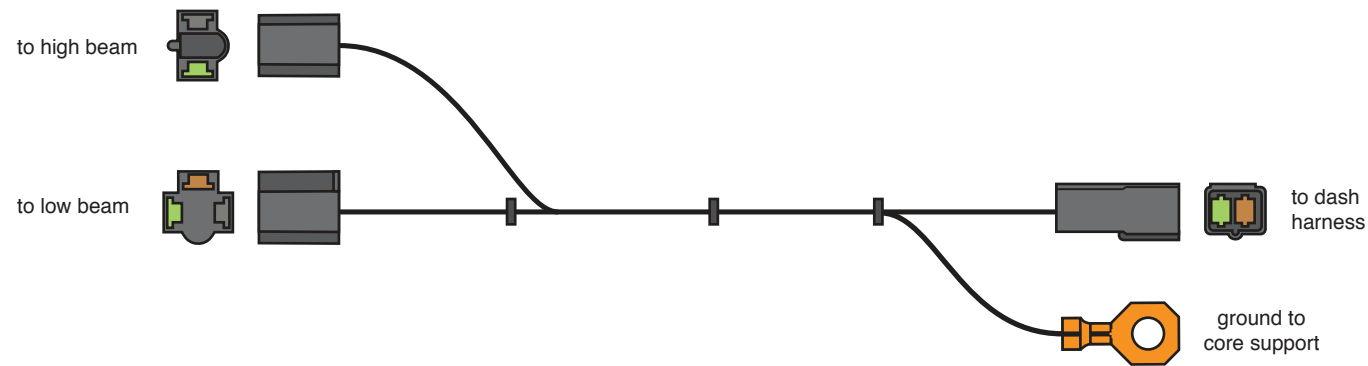
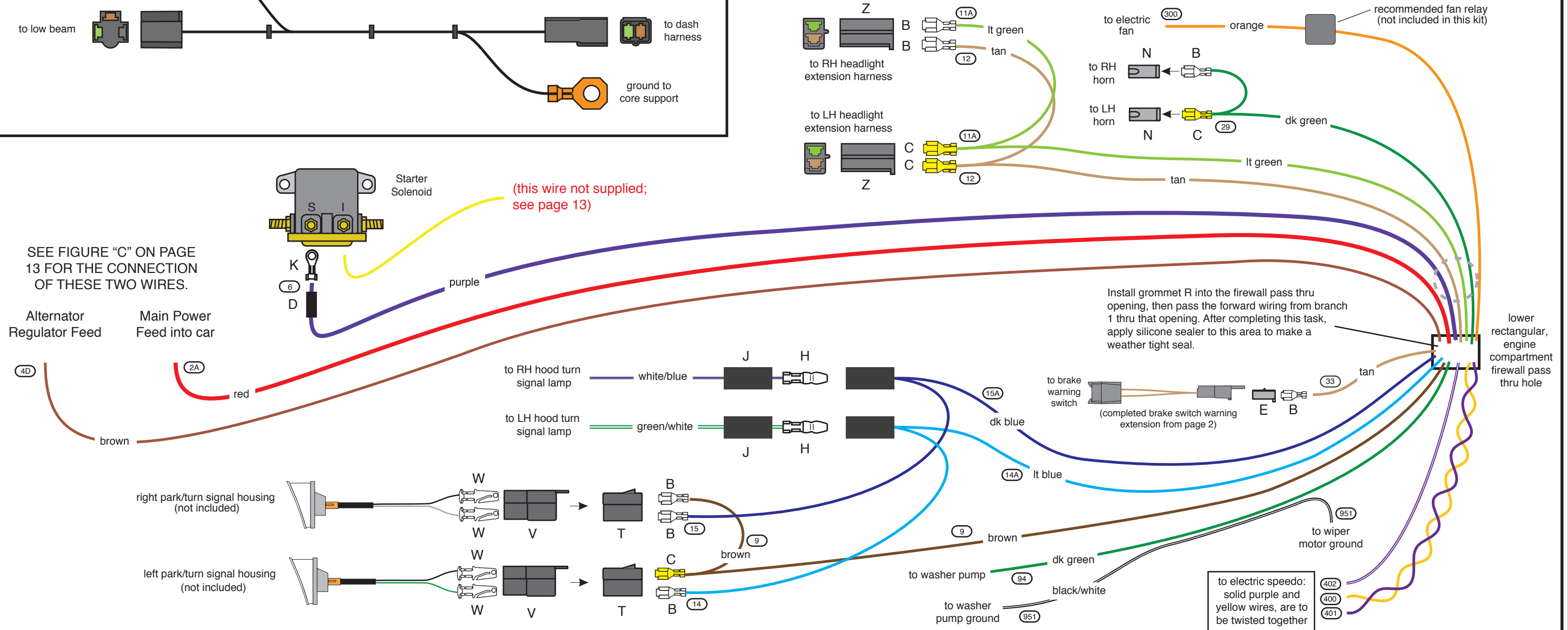

Figure "A"

Driver-Side, lower rectangular hole,
Engine Compartment Wiring

Head lamp, parking lamp, horn, brake warning, fan relay, washer pump, hood-mounted turn signal lamps, electric speedometer, main power, starter solenoid and alternator exciter.
These wires are all found at branch 1, pages 3, 4 and 5.



NOTE: The terminals and connectors listed on this page and denoted with UPPER CASE LETTERS, to help you complete the various connections to your lamps, horns, switches, etc., can be found in your loose piece clamp, grommet, and parts kit, P/N 510396.

The identifications, colors, and functions for all of the wires listed in "Figure A" on this page, can be found on pages 3, 4 and 5, branch 1 of this instruction set and in the headlight harness kit.



www.americanautowire.com 856-933-0801

PART # **510391**

DESCRIPTION:
1966-67 Ford Fairlane
1966-67 Mercury Comet
Classic Update Series Kit

92970603 Rev. 4.2 5/12/2020

Figure "B"
Driver-Side,
upper round hole,
Engine Compartment Wiring

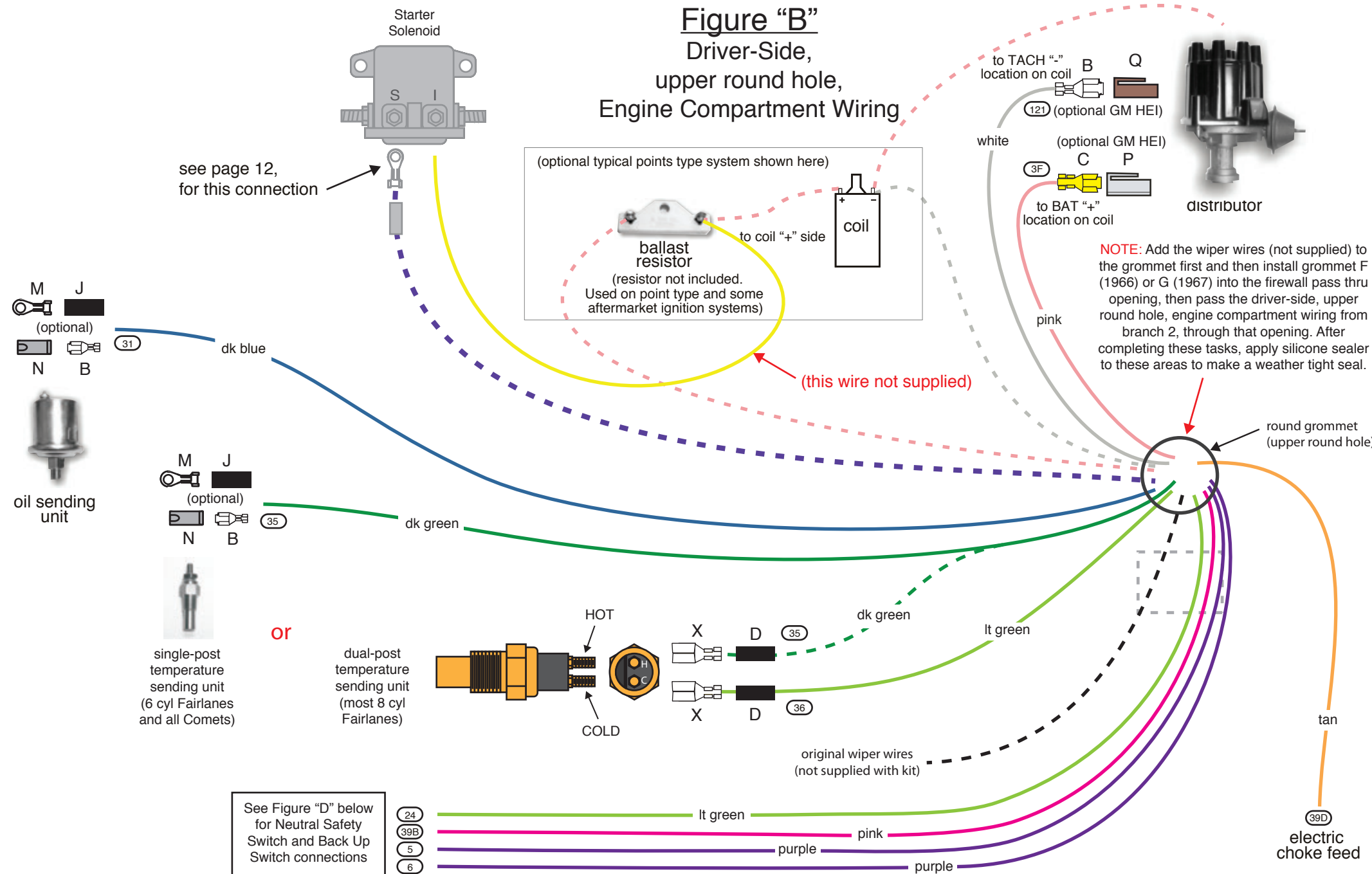

NOTE: The terminals and connectors listed on this page and denoted with **UPPER CASE LETTERS**, are to help you complete the various connections to your back-up and NSS switch, ignition feed, engine sensors, electric choke, tachometer and alternator output. They can all be found in your loose piece clamp, parts kit, P/N 510396.

AAW suggests and recommends using pages 5 & 6, to complete the installation of the Driver-Side, upper round hole, Engine Compartment Wiring.

AAW kits are all engineered to be used in conjunction with a high output, later model internally regulated, or one wire alternator. We do not suggest or support the use of a stock low amperage alternator as they do not supply sufficient current to recharge the battery in a highly modified car such as this kit was designed for. AAW suggests a Ford Gen III, a GM "SI", or a 1 wire type alternator as good choices to use. An adapter to complete the connection to the Ford Gen III style alternator (AAW p/n 500802) may be purchased separately. Contact AAW for your needs.

Figure "C"
Main Power and
Alternator Wiring

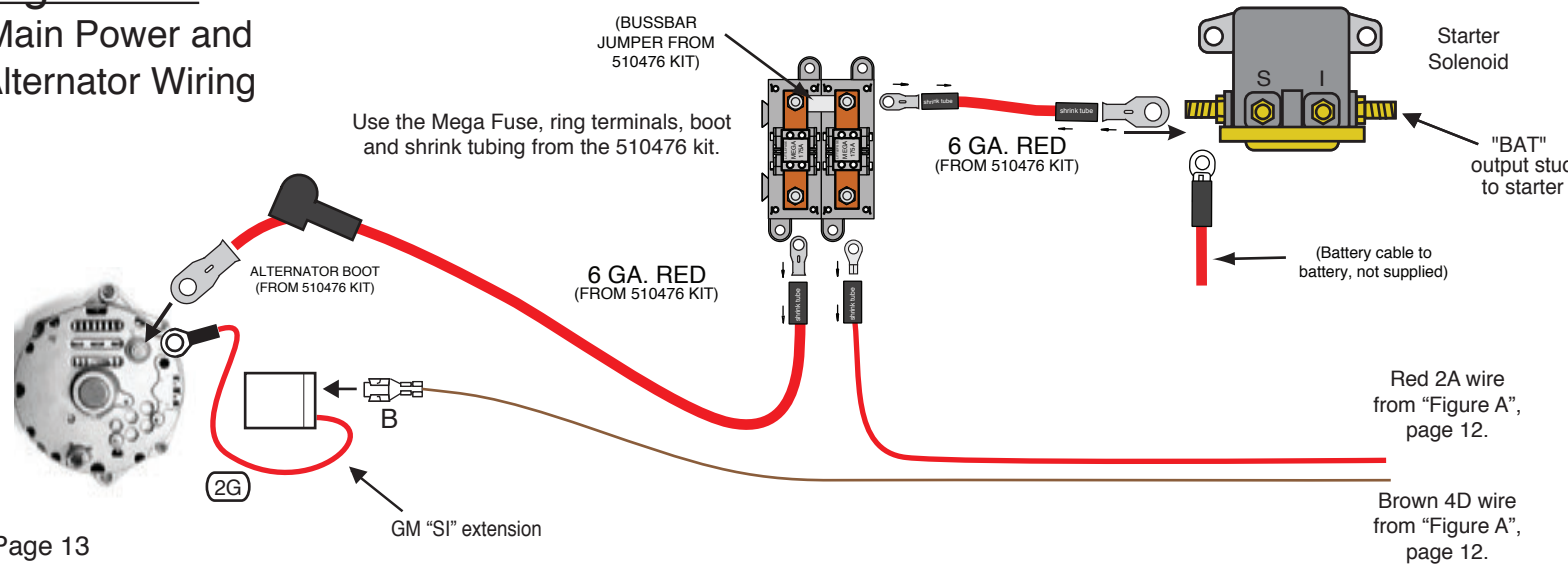
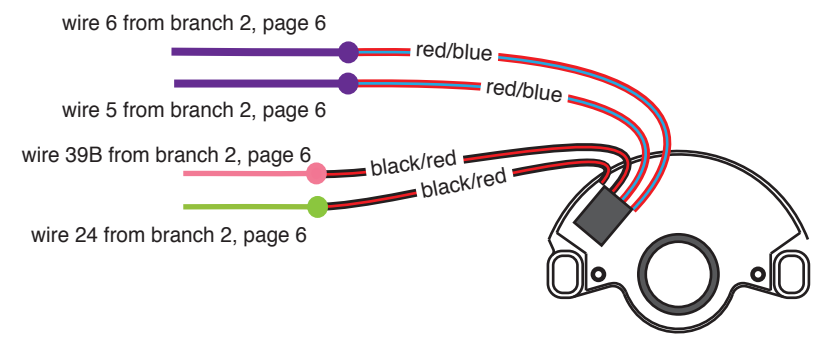

Figure "D"
Shown is a typical NSS
and Back Up Switch.



www.americanautowire.com 856-933-0801

PART # **510391**

DESCRIPTION:
1966-67 Ford Fairlane
1966-67 Mercury Comet
Classic Update Series Kit

92970603 Rev. 4.2 5/12/2020

FUSE AND FLASHER LOCATIONS

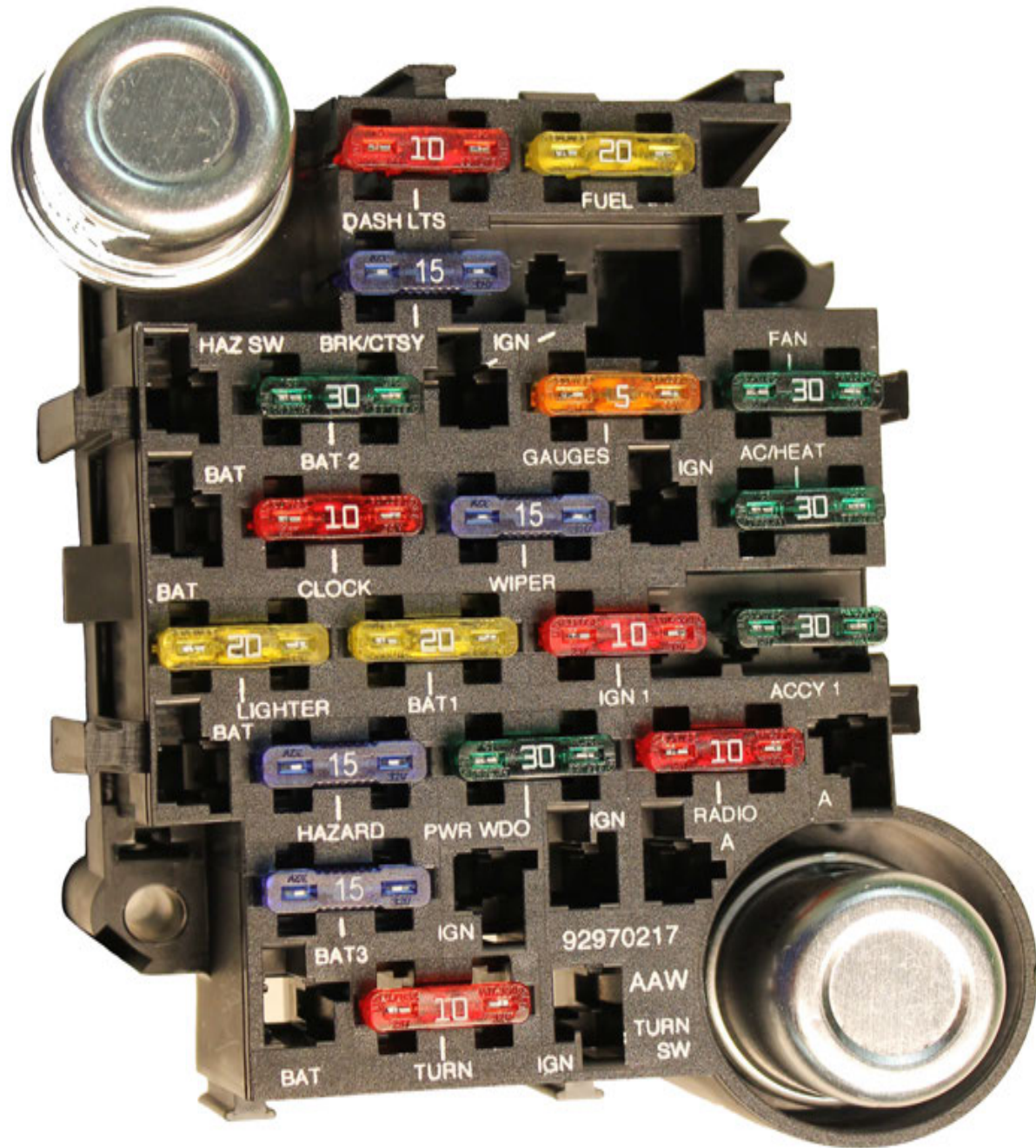

NOTE: Above, you will find a photograph of the completed Fuse Block assembly depicting the proper location for the installation of each fuse and the two flasher cans.

Figure "E"

Shown is 1966-67 Fairlane, single-speed wiper system factory wiring, for reference

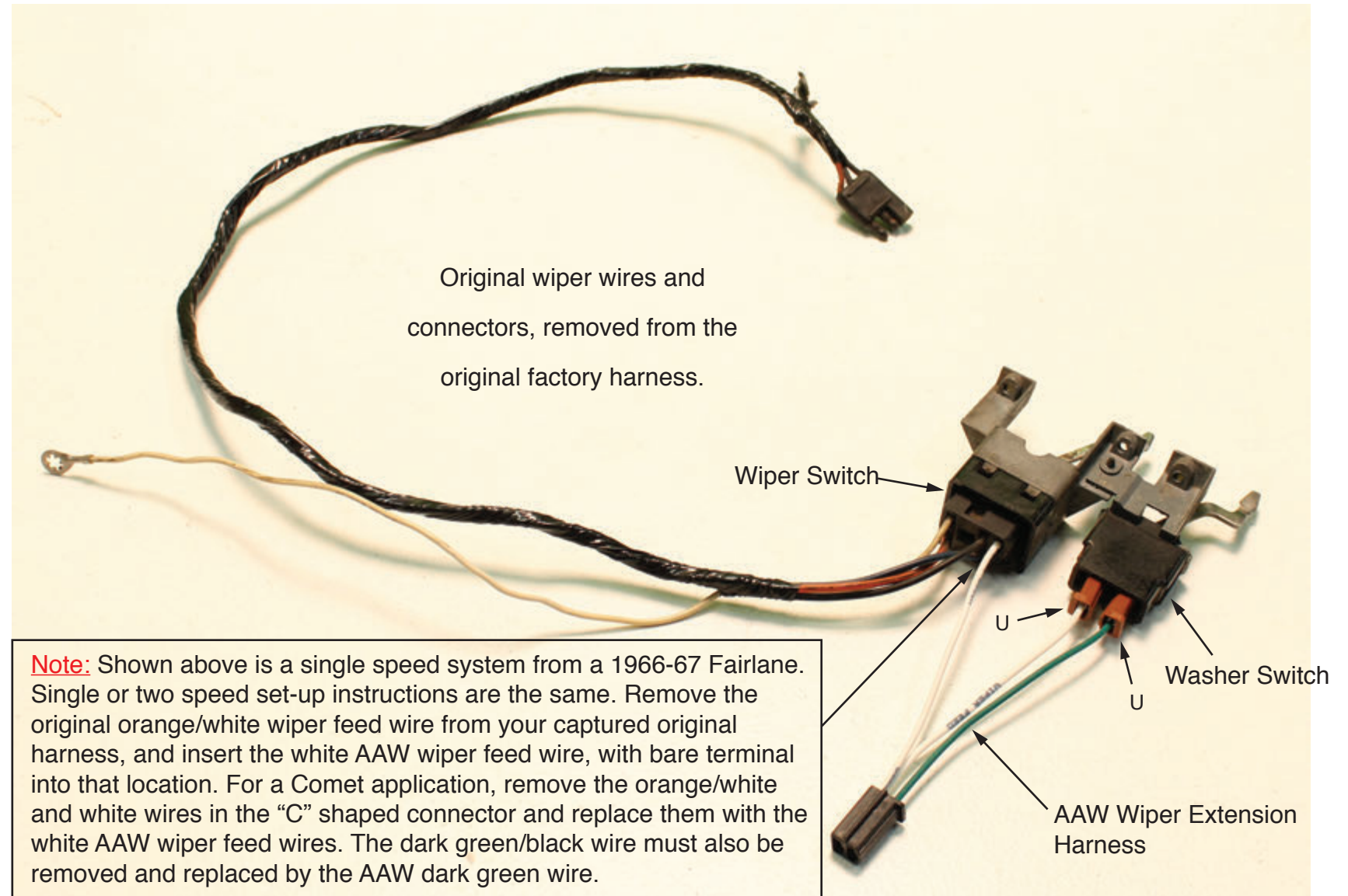

www.americanautowire.com 856-933-0801

PART # **510391**

DESCRIPTION:
1966-67 Ford Fairlane
1966-67 Mercury Comet
Classic Update Series Kit

92970603 Rev. 4.2 5/12/2020