

# Classic Update Series

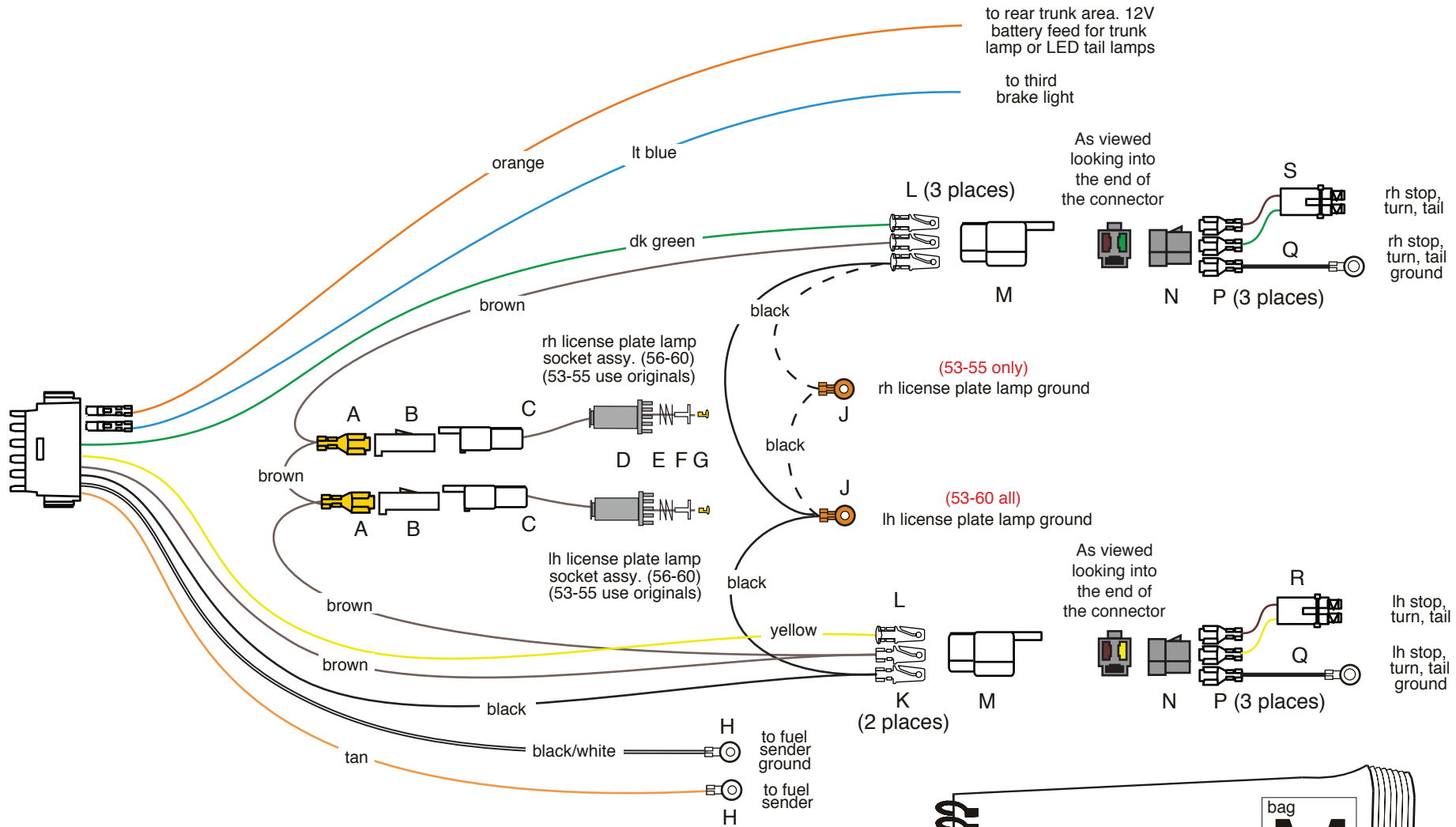

1953 - 1960 Corvette  
without Back Up Lamps



**American  
Autowire**

www.americanautowire.com 856-933-0801

Classic Update Series **M** bag

53-62 Corvette













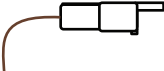



REAR BODY KIT

**510271**

92969859 instruction rev 0.0 6/23/2011

## 1953-1960 Corvette (See sheet 1)

Connect the main connector to the mating connector on the dash harness 510269 bag G. Route this harness down the driver's door sill & into the trunk.

A		LIGHT BLUE	Third brake light	If you are using a third brake light, plug this wire into the main connector maintaining color continuity with the dash/main harness, P/N 510269, then connect the loose end of the wire to your third brake lamp assembly.
B		TAN	Fuel Tank Sender	Route this wire to the rear of the car close to the exit hole in the trunk floor, then down to the fuel tank sender, install terminal H and attach to the sending unit to complete the fuel tank sender connection.
C		BLACK/WHITE	(No Printing)	This is your dedicated fuel tank sender ground lead. Route this wire to the rear of the car (along the side of the tan fuel tank sender wire from above) close to the exit hole in the trunk floor, then down to the fuel tank sender area, install terminal H and attach to the frame of the sending unit to complete the fuel tank sender ground connection.
D				<b>Note:</b> Two new license lamp leads C have been provided for you. If you are doing a '53-'55 car, you will need to re-use your old lamp sockets as they are not available. If you are doing a 1956-60 car, assemble the extension leads using socket, insert, spring and rivet, D, E, F, and G as shown on page 1. These finished extensions will plug onto connectors B as shown on sheet 1 to complete your two license lamp connections. Also, new Stop/Tail lamp pigtails R and S (yellow and brown for LH driver's side, and green and brown for RH passenger's side) along with ground wires Q have been provided. Install terminal P on each wire and plug them into connector N maintaining color continuity as shown on sheet 1. These pigtails will plug onto connectors M to complete your rear lighting in a step below.
E				
F				
G				
H		BROWN	Running lamps	Route this wire to the LH tail lamp area, cut to length, double this wire with the cut off portion, install terminal K and plug into connector M in the location shown on sheet 1 maintaining color continuity with the LH tail lamp pigtail from above. Route the loose end of this brown wire to the LH license lamp area, cut to length, double this wire with the cut off portion, install terminal A and plug into connector B as shown on sheet 1. Route the loose end of this brown wire to the RH license lamp area, cut to length, double this wire with the cut off portion, install terminal A and plug into connector B as shown on sheet 1. Route the loose end of this brown wire to the RH tail lamp area, cut to length, install terminal L and plug into connector M in the location shown on sheet 1 maintaining color continuity with the RH tail lamp pigtail from above. Do not plug your completed tail lamp pigtails from above onto this connection yet.
J				Route this wire to the LH tail lamp area, cut to length, install terminal L and plug into the empty cavity of connector M as shown on sheet 1 maintaining color continuity with the LH tail lamp pigtail from above. Do not plug your completed LH tail lamp pigtail from above onto this connection yet. Plug LH pigtail B (yellow, brown and black wires) from above onto this connection to complete the LH stop, turn, and tail circuits.
K				
L		YELLOW	LH Stop / Tail	Route this wire to the RH tail lamp area, cut to length, install terminal L and plug into the empty cavity of connector M as shown on sheet 1 maintaining color continuity with the RH tail lamp pigtail from above. Do not plug your completed RH tail lamp pigtail from above onto this connection yet. Plug RH pigtail B (dk green, brown and black wires) from above onto this connection to complete the RH stop, turn, and tail circuits.
M				
N		DK GREEN	RH Stop / Tail	If your car has a trunk lamp or you are using LED tail lamps that require a 12v fused battery feed, plug this wire into the main connector maintaining color continuity with the dash/main harness, P/N 510269, then connect the loose end of the wire to the trunk lamp or 12v battery feed for the LED tail lamps.
P		ORANGE	12V Battery Feed	
Q		BLACK	Ground	<b>Note:</b> Four new tail lamp ground wires Q have been provided for you. Only two will be used in this application as outlined above. Route this wire to the LH tail lamp area, cut to length, double this wire with the cut off portion, install terminal K and plug into connector M in the location shown on sheet 1 maintaining color continuity with the LH tail lamp pigtail from above. Route the loose end of this black wire to the LH license lamp area, cut to length, double this wire with the cut off portion, and install terminal J as shown on sheet 1. <b>If your car is a '53-'55 car</b> , route the loose end of this black wire to the RH license lamp area, cut to length, double this wire with the cut off portion, and install terminal J as shown on sheet 1. <b>Continuing with a '53-'55 car</b> , route the loose end of this black wire to the RH tail lamp area, cut to length, install terminal L and plug into connector M in the location shown on page 1 maintaining color continuity with the RH tail lamp pigtail from above. <b>If your car is a '56-'60 car</b> , route the loose end of this black wire to the RH tail lamp area, cut to length, install terminal L and plug into connector M in the location shown on sheet 1 maintaining color continuity with the RH tail lamp pigtail from above. You may now plug your completed tail lamp pigtails from above onto these two tail lamp connections. Your rear body connections are now completed.
R				
S				

# Classic Update Series

**NOTE:** Back up lamps on an early Corvette were never offered. If your car has been customized to add them, you will need to purchase the optional Back Up Lamp kit, P/N 510330, to make those connections. If your car has been customized to add a third stop/tail lamp assembly the rear of your car, you will need to purchase the optional 3rd Stop/Tail Lamp kit, P/N 510329, to make those connections.

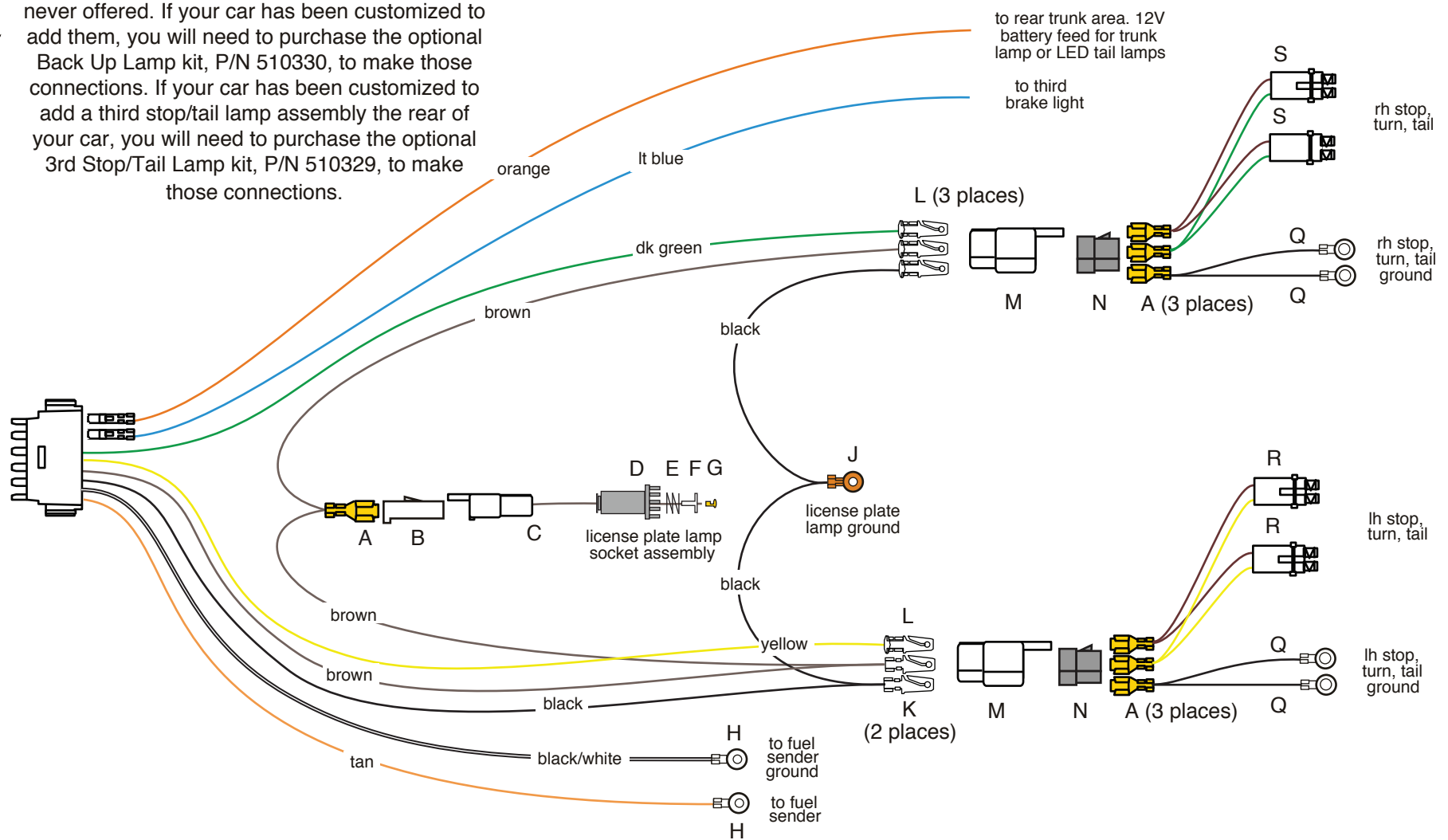













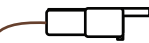

**1961 - 1962 Corvette**  
 without Back Up Lamps.  
 (For a car with Back Up Lamps,  
 see optional kit number 510330.  
 For a car with 3 Stop/Tail Lamps,  
 see optional kit number 510329)

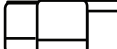

www.americanautowire.com 856-933-0801

Classic Update Series **M**  
 53-62 Corvette  
**REAR BODY KIT**  
**510271**  
 92969859 instruction rev 0.0 6/23/2011

## 1961 - 1962 Corvette without Back Up Lamps (See sheet 3)

A		Connect the main connector to the mating connector on the dash harness 510269 bag G. Route this harness down the driver's door sill & into the trunk.	
B		Third brake light If you are using a third brake light, plug this wire into the main connector maintaining color continuity with the dash/main harness, P/N 510269, then connect the loose end of the wire to your third brake lamp assembly.	
C		TAN Fuel Tank Sender Route this wire to the rear of the car close to the exit hole in the trunk floor, then down to the fuel tank sender, install terminal H and attach to the sending unit to complete the fuel tank sender connection.	
D		BLACK/WHITE (No Printing) This is your dedicated fuel tank sender ground lead. Route this wire to the rear of the car (along the side of the tan fuel tank sender wire from above) close to the exit hole in the trunk floor, then down to the fuel tan sender area, install terminal H and attach to the frame of the sending unit to complete the fuel tank sender ground connection.	
E		<p><b>Note:</b> Two new license lamp leads C have been provided for you. For the 1961-62 application, you will only be using one of these pigtails. On a 1961-62 car, assemble the extension lead using socket, insert, spring and rivet, D, E, F, and G as shown on sheet 3. This finished pigtail extension will plug onto connector B as shown on sheet 3 to complete your license lamp connection. Also, four new Stop/Tail lamp pigtails R and S (2 yellow and brown for LH driver's side, and 2 dk green and brown for RH passenger's side) along with four ground wires Q have been provided. Double the LH yellow wires together and then LH brown wires together, install terminal A on each connection and plug the yellow and the brown doubled wires into connector N maintaining color continuity as shown on sheet 3. Repeat this process for the RH dk green and brown wires. Double two of the ground wires Q together, install terminal A on each connection and plug the black doubled wires into connector N maintaining color continuity as shown on sheet 3. These pigtails will plug onto connectors M to complete your rear lighting in a step below.</p>	
F			
G			
H			
J			BROWN Running lamps Route this wire to the LH tail lamp area, cut to length, double this wire with the cut off portion, install terminal K and plug into connector M in the location shown on sheet 3 maintaining color continuity with the LH tail lamp pigtail from above. Route the loose end of this brown wire to the license lamp area, cut to length, double this wire with the cut off portion, install terminal A and plug into connector B as shown on sheet 3. Route the loose end of this brown wire to the RH tail lamp area, cut to length, install terminal L and plug into connector M in the location shown on sheet 3 maintaining color continuity with the RH tail lamp pigtail from above. Do not plug your completed tail lamp pigtails from above onto this connection yet.
K			
L			
M		YELLOW LH Stop / Tail Route this wire to the LH tail lamp area, cut to length, install terminal L and plug into the empty cavity of connector M as shown on sheet 3 maintaining color continuity with the LH tail lamp pigtail from above. Do not plug your completed LH tail lamp pigtail from above onto this connection yet.	
N		DK GREEN RH Stop / Tail Route this wire to the RH tail lamp area, cut to length, install terminal L and plug into the empty cavity of connector M as shown on sheet 3 maintaining color continuity with the RH tail lamp pigtail from above. Do not plug your completed RH tail lamp pigtail from above onto this connection yet.	
P		ORANGE 12V Battery Feed If your car has a trunk lamp or you are using LED tail lamps that require a 12v fused battery feed, plug this wire into the main connector maintaining color continuity with the dash/main harness, P/N 510269, then connect the loose end of the wire to the trunk lamp or 12v battery feed for the LED tail lamps.	
Q		BLACK Ground <b>Note:</b> Four new tail lamp ground wires Q have been provided for you. Installation info these wires is outlined in the <b>Note</b> above. Route this wire to the LH tail lamp area, cut to length, double this wire with the cut off portion, install terminal K and plug into connector M in the location shown on sheet 3 maintaining color continuity with the LH tail lamp pigtail from above. Route the loose end of this black wire to the license lamp area, cut to length, double this wire with the cut off portion, and install terminal J as shown on sheet 3. Route the loose end of this black wire to the RH tail lamp area, cut to length, install terminal L and plug into connector M in the location shown on sheet 3 maintaining color continuity with the RH tail lamp pigtail from above. You may now plug the completed LH pigtail R (yellow, brown, and black wires) and the completed RH pigtail S (dk green, brown, and black wires) from above onto these 2 new tail lamp connections to complete the LH and RH stop, turn, and tail circuits. Your rear body connections are now completed.	
R			
S	