

*** These are special instructions for connecting your wiring system to the stock instrument clusters. ***

Note: If you are using after market gauges, follow the instructions included in the 92968220 Gauge Connection Kit along with the specific gauge manufacturers instructions for connection of their gauges.

If you are using the stock gauges, refer to the diagrams on the following pages for your application. Use the enclosed parts and information below for wire termination, gauge, and lamp connections. Connectors A,B,C, and D will plug into your dash harness as noted on the Dash Harness instruction set (510269, bag G). Connection D will only be used in the event that you are using an electric speedometer.

CONNECTOR A (sheet 2)

DK BLUE	Right Turn Indicator	Install components as shown on sheet 2, and plug into the right turn hole in cluster.
LT BLUE	Left Turn Indicator	Install components as shown on sheet 2, and plug into the left turn hole in cluster.
LT GREEN	Hi Beam Indicator Lamp	Install components as shown on sheet 2, and plug into the high beam hole in cluster.
GRAY	Instrument Lamps	Install components as shown on sheet 2, and plug into the instrument lamp holes in the speedometer cluster and tach housing.
BLACK	Ground	Connect to the back of the speedometer cluster housing ('58-'62) using ring terminal C (smaller hole), or under the LH mounting bolt of the speedometer cluster ('53-'57) using ring terminal D (larger hole) as shown on sheet 2.
PINK	12v ignition (loose wire)	If your car is equipped with an electric tach requiring a 12v ignition feed, plug this loose wire into Connector A maintaining color continuity with the mating connector on your dash harness, install components as shown on sheet 2, and attach to the tachometer per the manufacturer's instructions..
WHITE	Tach (loose wire)	If your car is equipped with an electric tach, plug this loose wire into Connector A maintaining color continuity with the mating connector on your dash harness, install components as shown on sheet 2, and attach to the tachometer per the manufacturer's instructions.

CONNECTOR B (sheet 3)

DK GREEN	Temp Gauge	Install components as shown on sheet 3, and attach to the temperature gauge sender post.
TAN	Fuel Gauge	Install components as shown on sheet 3, and attach to the fuel gauge sender post.
PINK	12v ignition	Install components as shown on sheet 3, and attach to the fuel and temp gauge 12v ignition feed posts.
GRAY	Instrument Lamps	Install components as shown on sheet 3, and plug into the instrument lamp hole in the fuel and temp gauge pod cluster.

CONNECTOR C (sheet 3)

GRAY	Instrument Lamps	NOTE: The oil pressure gauge was a mechanical unit on a stock Corvette and the stock original ammeter is not supported in this aftermarket upgraded kit, so if you are using the stock gauges, you will only use the gray lamp wire for this cluster pod assembly. Install components as shown on sheet 3, and plug into the instrument lamp hole in the ammeter and oil gauge pod cluster.
DK BLUE	Oil Gauge (loose wire)	If your car is equipped with an aftermarket electric oil pressure gauge, plug this loose wire into Connector C maintaining color continuity with the mating connector on your dash harness, install components as shown on sheet 3, and attach to the oil pressure gauge per the manufacturer's instructions.
PINK	12v ignition (loose wire)	If your car is equipped with an aftermarket electric oil pressure gauge or voltmeter requiring a 12v ignition feed, plug this loose wire into Connector C maintaining color continuity with the mating connector on your dash harness, install components as shown on sheet 3, and attach to the oil pressure gauge or voltmeter per the manufacturer's instructions.
BLACK	Ground (loose wire)	If your car is equipped with an aftermarket voltmeter, this is the ground for that voltmeter. Attach the factory ring terminal end of this wire to the grounding location on the bottom of the dash on a "53-"57 car, or to the lighter and clock ground location on a '58-'62 car, and attach the other end to the voltmeter (-) terminal as shown on sheet 3 and per the manufacturer's instructions.

CONNECTOR D (sheet 4)

This connector is used when using an aftermarket electronic speedometer only. Follow the manufacturer's instructions when installing these wires. If you are using the stock speedometer, then discard this connector. See page 4 for wire descriptions and typical connctions.

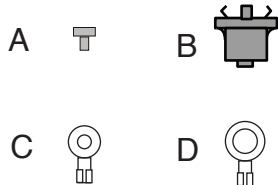

**American
Autowire**

www.americanautowire.com 856-933-0801



Classic Update Series

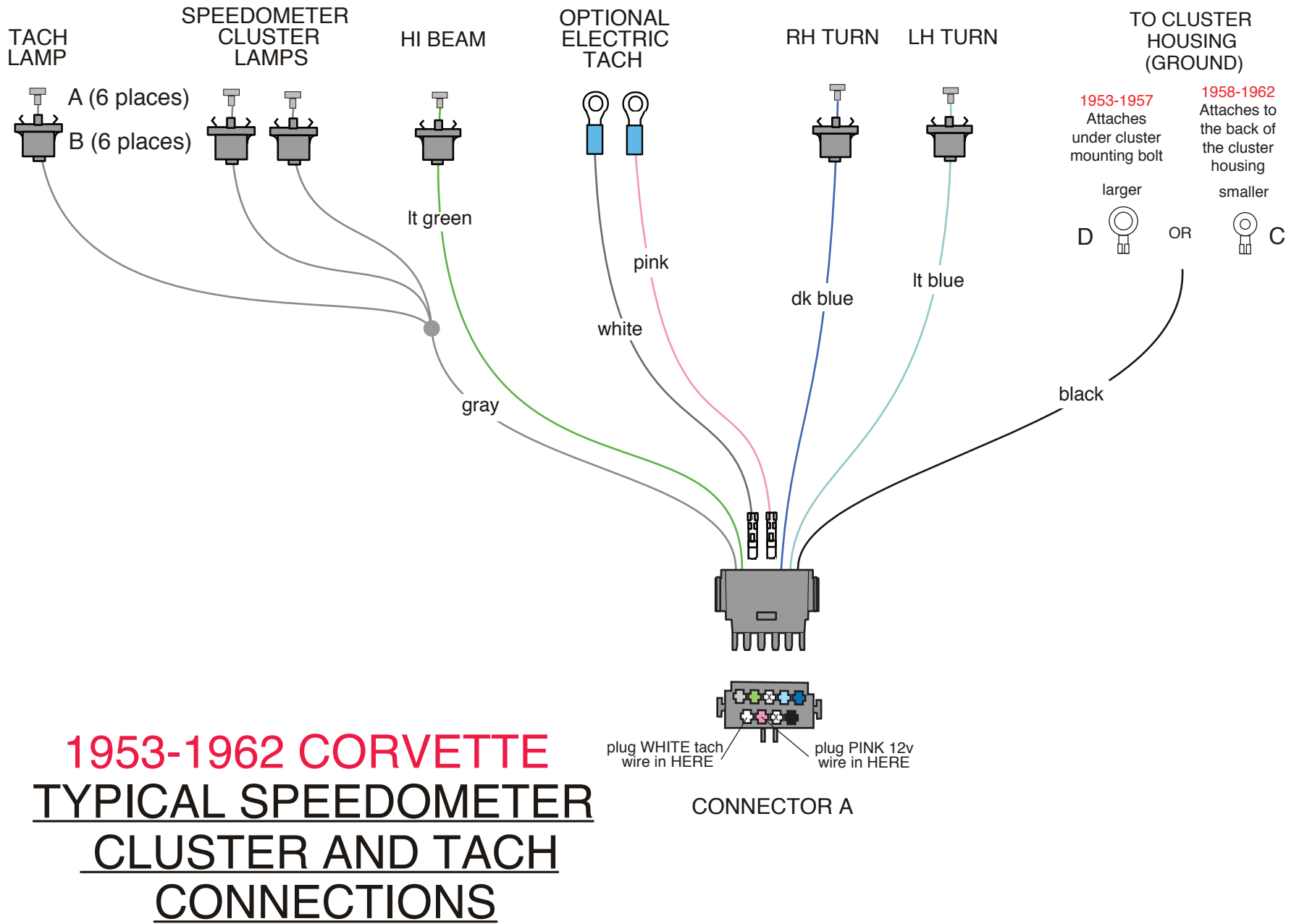

Classic Update Series

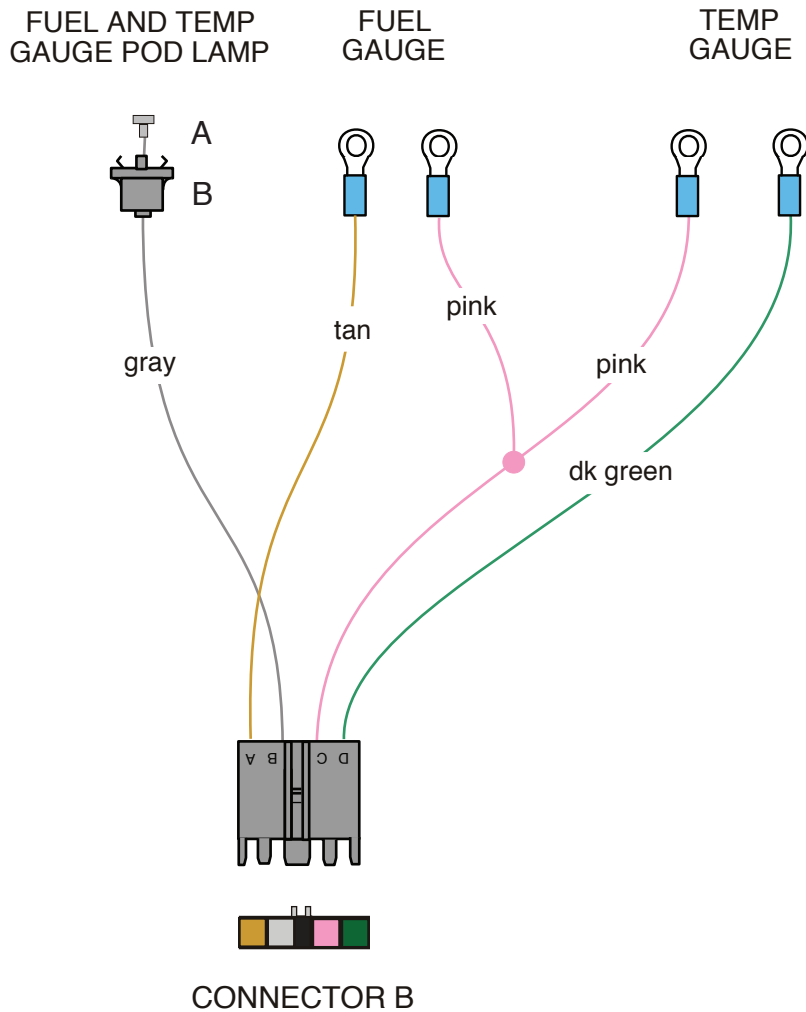

1953-1962 CORVETTE FUEL AND TEMP GAUGE POD CONNECTIONS

Optional upgraded electric oil pressure and voltmeter connections are depicted below. If your car uses the stock mechanical oil pressure gauge, these connections WILL NOT be used. This kit DOES NOT support the use of an ammeter.

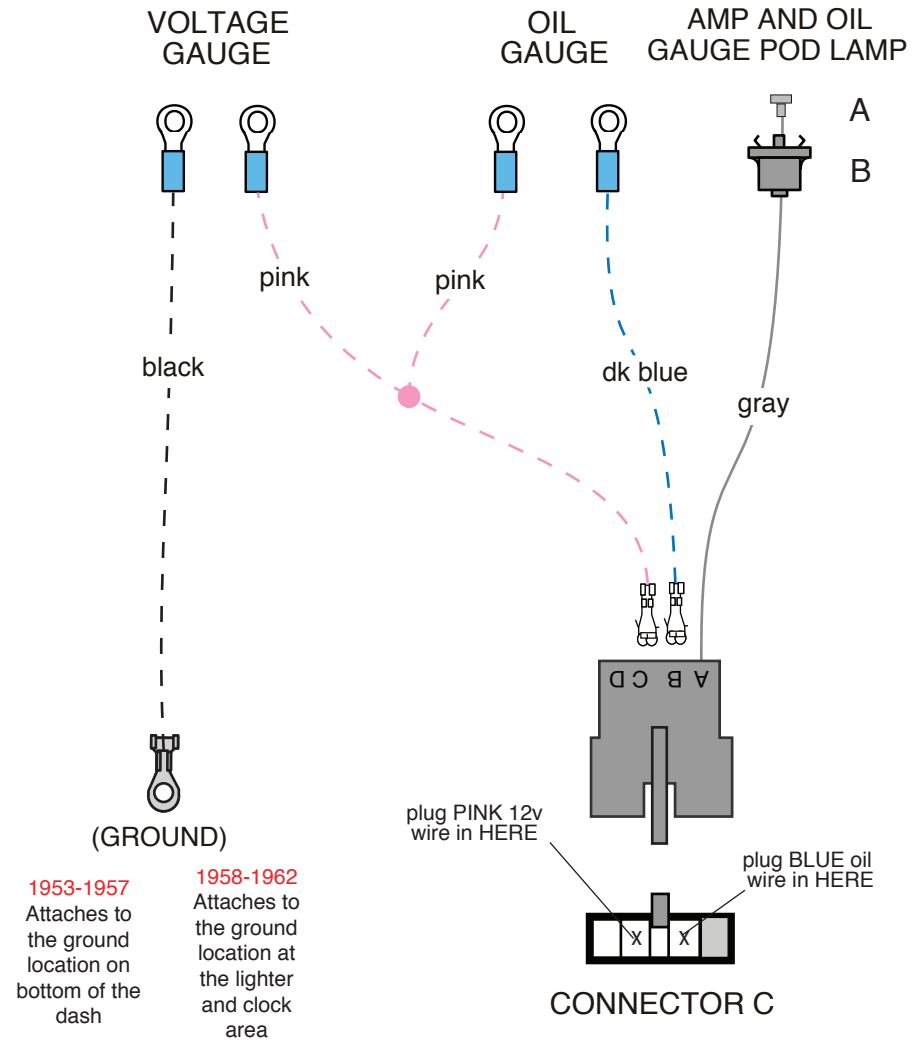

1953-1962 CORVETTE AMP AND OIL GAUGE POD CONNECTIONS

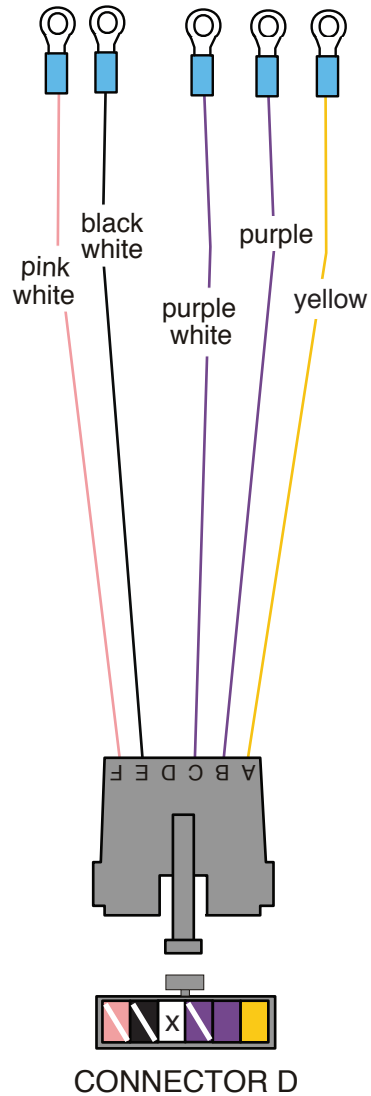

TYPICAL ELECTRIC SPEEDO CONNECTIONS

Below are some general instructions for hooking up an electric speedometer. This connector and these instructions will ONLY be used in the event that you are utilizing an aftermarket electric speedometer. If your car does NOT have an electric speedometer, this connection will NOT be used and should not be plugged onto your dash harness. It is best to consult the speedometer manufacturer's instructions if you have any questions.

<u>Yellow</u>	VSS Ground	Connect to VSS "-" on speedometer.
<u>Purple</u>	VSS Pulse	Connect to VSS input on speedometer.
<u>Purple/White</u>	VSS Power	Connect to 12V power on speedometer.
<u>Black/White</u>	Speedo Ground	Connect to ground on speedometer.
<u>Pink/White</u>	Speedo Power	Connect to 12v power on speedometer. NOTE: This wire will double onto the same stud as the purple/white VSS power wire from above.



www.americanautowire.com 856-933-0801

TYPICAL AFTERMARKET GAUGE CONNECTIONS
(STUD TYPE CONNECTIONS SHOWN)

GAUGE CONNECTIONS

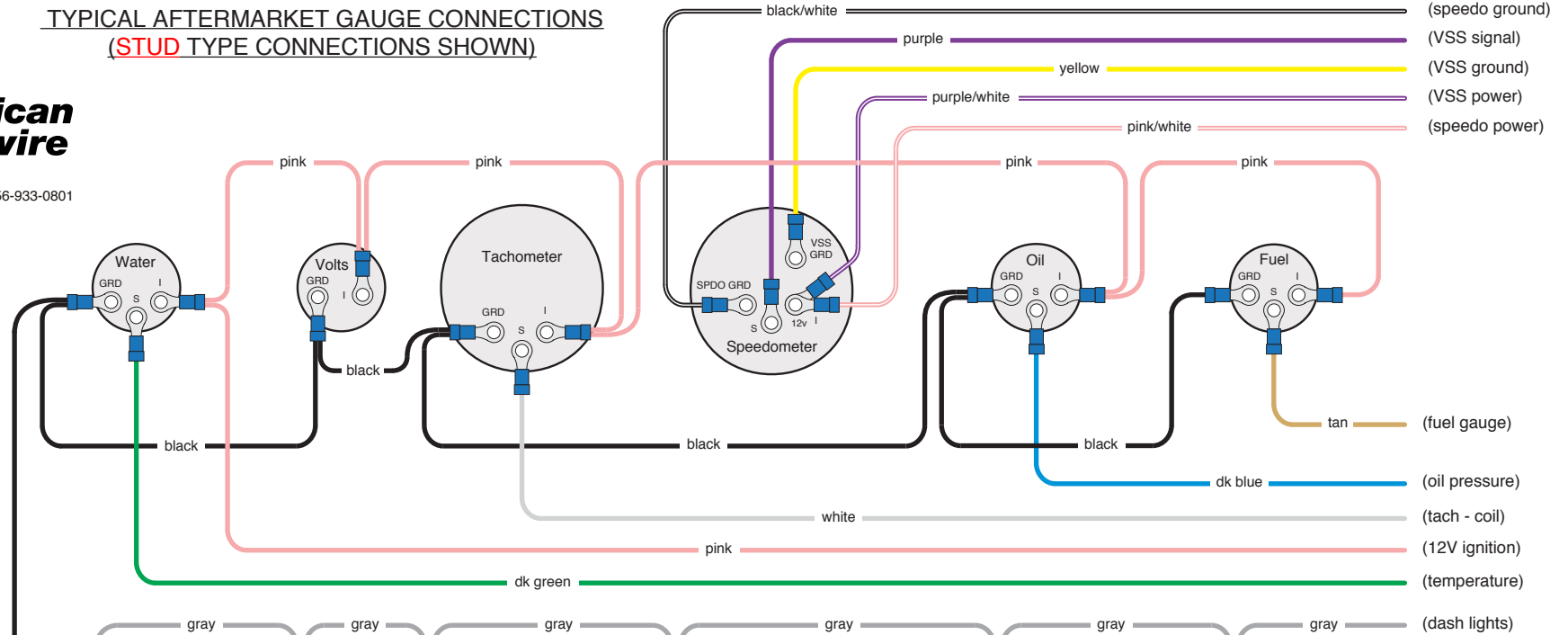

LAMP CONNECTIONS

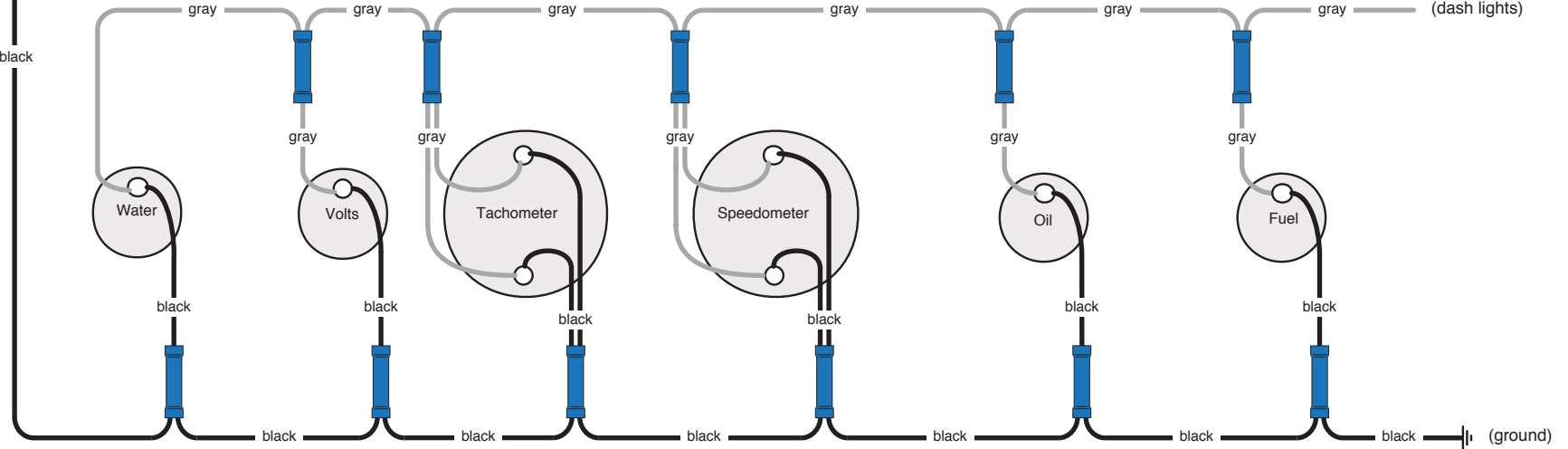

TURN SIGNAL AND HI-BEAM LAMP CONNECTIONS

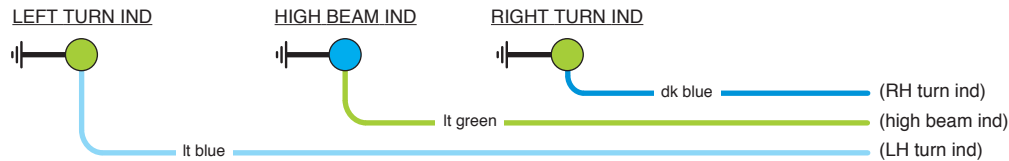

PART # **92965220**
Gauge Connection Kit
 Complete connections
 for aftermarket gauges

92965221 Rev 1.1 12/12/2014



**American
Autowire**

www.americanautowire.com 856-933-0801

TYPICAL AFTERMARKET GAUGE CONNECTIONS
(BLADE TYPE CONNECTIONS SHOWN)

GAUGE CONNECTIONS

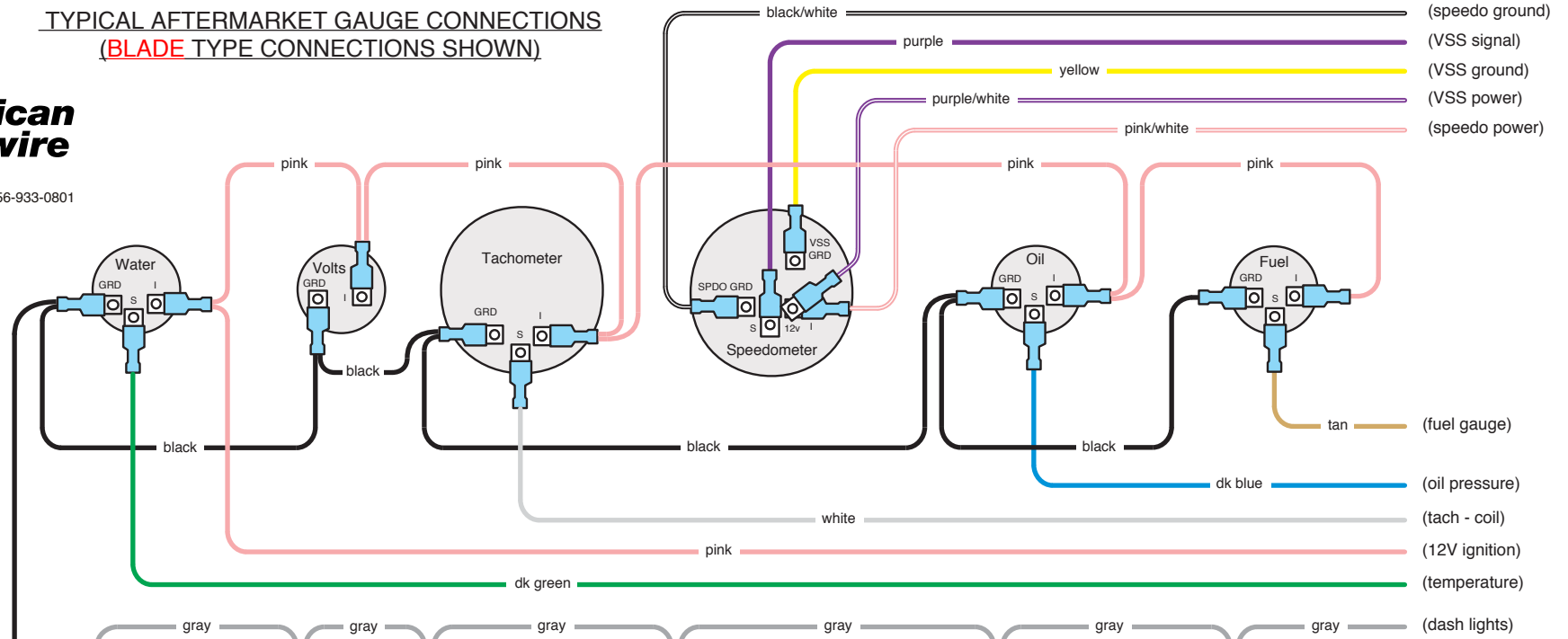

LAMP CONNECTIONS

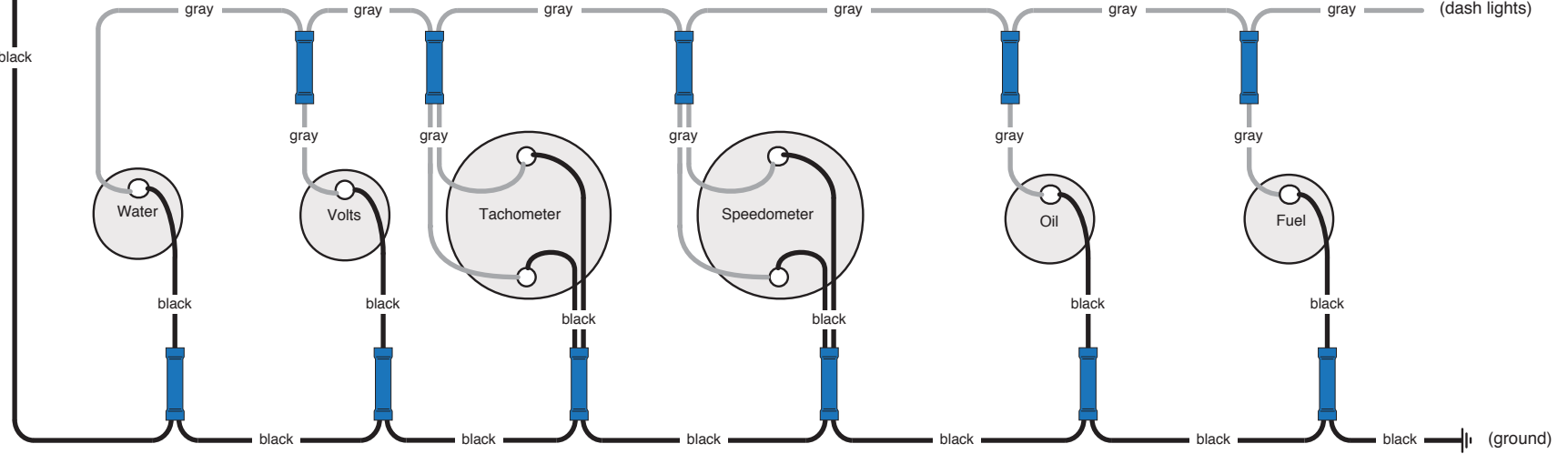

TURN SIGNAL AND
HI-BEAM LAMP
CONNECTIONS

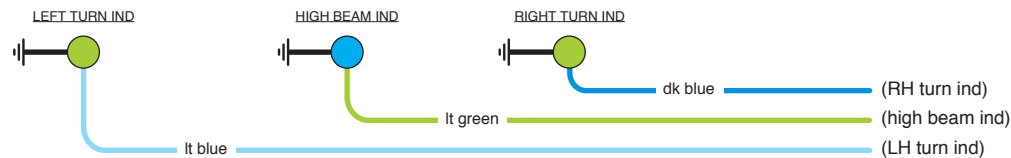

PART # **92965220**
Gauge Connection Kit

Complete connections
for aftermarket gauges

92965221 Rev 1.1 12/12/2014