

HIGHWAY 15 NOSTALGIA WIRING KIT

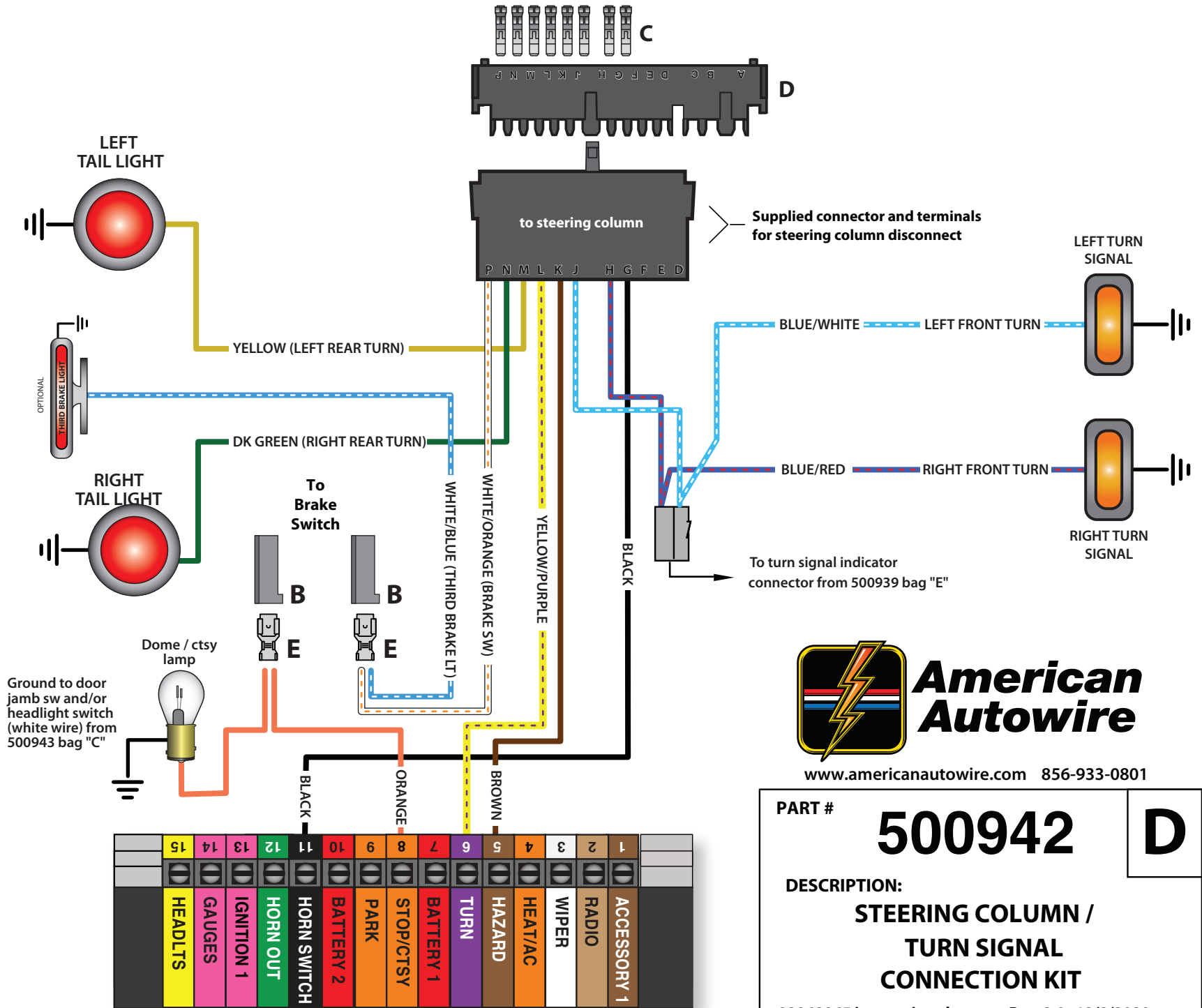

**American
Autowire**

www.americanautowire.com 856-933-0801

PART #

500942

D

DESCRIPTION:

**STEERING COLUMN /
TURN SIGNAL
CONNECTION KIT**

92968065 instruction sheet

Rev 2.0 12/8/2020

INSTALLATION INSTRUCTIONS

This kit has a GM steering column connector supplied on the wires. This connector will plug into most GM columns for 1969-1974 (along with most aftermarket columns) If your existing column connector does not match the connector on this kit, install the mating connector "D" and terminals "C" which are supplied, as shown below.

Install the remaining wires as follows:

WIRE COLOR	CIRCUIT	INSTALLATION
YELLOW	LEFT TAIL LAMP	Route and connect this wire to your left tail light (stop, and turn location)
DK GREEN	RIGHT TAIL LAMP	Route and connect this wire to your right tail light (stop, and turn location)
BLUE/WHITE	LEFT FRONT TURN	Route and connect this wire to the left front turn signal lamp (turn location)
BLUE/RED	RIGHT FRONT TURN	Route and connect this wire to the right front turn signal lamp (turn location)
ORANGE	BRAKE SWITCH FEED IN	Insert one end into the "STOP / CRTSY" location on the panel, route the wire to the brake switch and cut to length. With the cut off portion of this orange wire, double the two ends together using terminal "E", install in connector "B" and plug into the brake switch. The remaining loose end will route to the dome/courtesy lamp as shown on page 1.
WHITE/ORANGE	BRAKE SWITCH FEED OUT	Route this wire to the brake switch and cut to length. If you are using a third brake light, do not terminate yet (see WHITE/BLUE wire below). If you are not using a third brake light, use the supplied terminal "A" and connector "B", and plug into your brake switch.
WHITE/BLUE	THIRD BRAKE LIGHT	If you are not using a third brake light, ignore the installation of this wire. Otherwise, double this wire with the WHITE / ORANGE "Brake switch feed out" wire from above using the supplied terminal "E" and connector "B" and plug into the brake switch. Route the other end of WHITE/BLUE wire to the third brake light.
BLACK/WHITE	HORN GROUND	Route this wire to the panel and insert it into the "HORN SW" location on panel.
YELLOW/PURPLE	TURN SIGNAL FLASHER	Route this wire to the panel and insert it into the "TURN SW" location on panel.
BROWN	HAZARD FLASHER	Route this wire to the panel and insert it into the "HAZARD" location on panel.
LT BLUE/WHITE	TURN SIGNAL INDICATOR	Plug this 2 wire connector assembly wire into the 2 position connector in the 500939 kit.
DK BLUE/WHITE		

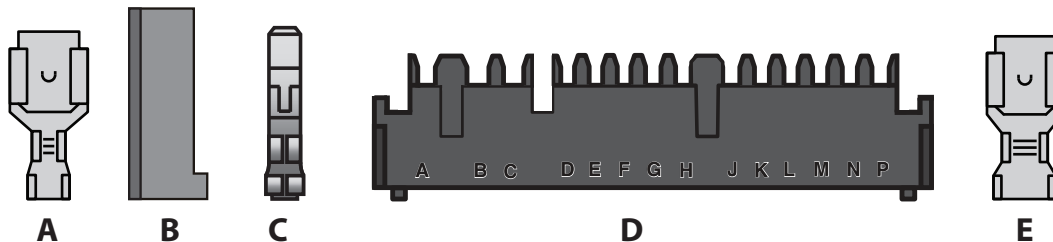

PART #

500942

D

DESCRIPTION:

**STEERING COLUMN /
TURN SIGNAL
CONNECTION KIT**

92968065 instruction sheet Rev 2.0 12/8/2020