

NOTE: If the fuse panel on your 510691 71-74 Mopar B-Body kit **HAS** a sticker like the photo at the left, you have the second design harness and your instructions are listed below and follow this page.

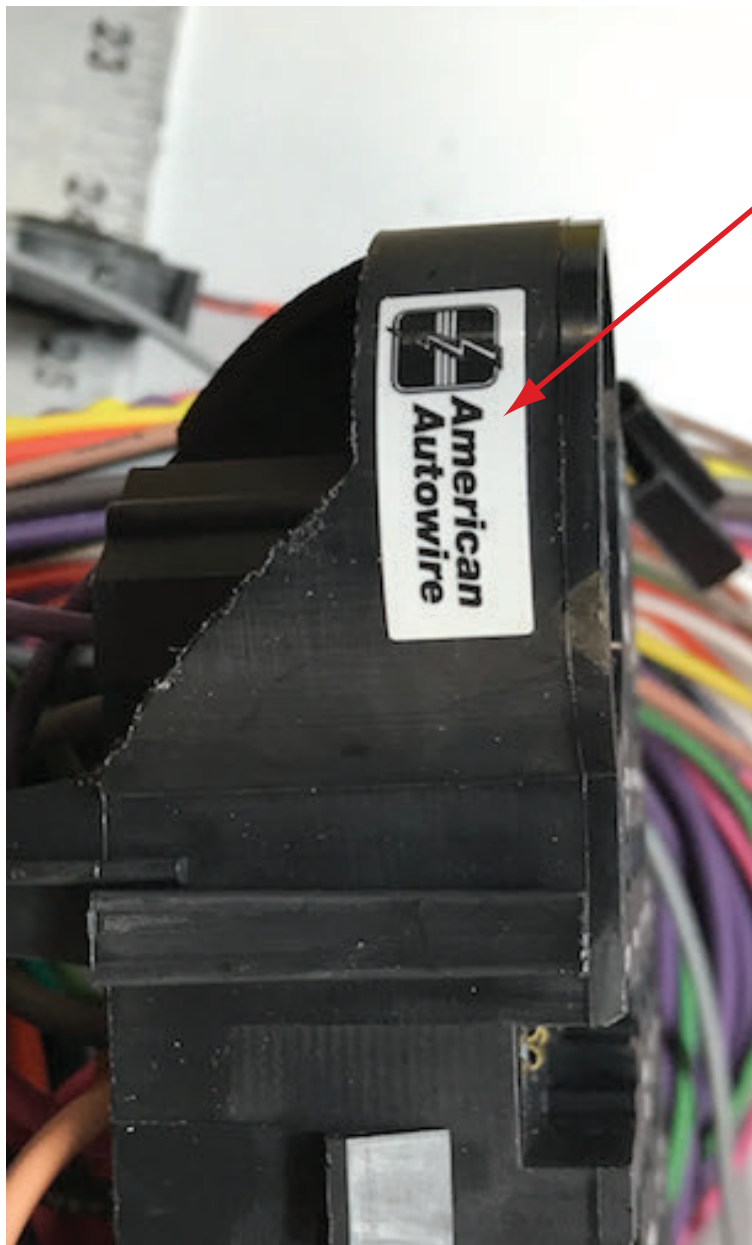

Number	Description
500698	Headlight Switch
500697	Fuse, Relay, and Flasher kit
500919	Practice Terminal Crimping Set
510787	Dash Harness kit
510786	Engine Wiring Kit
510695	Front Light Wiring kit
510788	Instrument Cluster Wiring kit
510696	Rear Body Wiring kit
510476	Alternator and main power Connection kit
510730	VSS Connection kit
500042	Floor Dimmer Switch
92971839	Firewall Mod. Template Sheet
92972832	Main Instruction Sheet



**American
Autowire**

www.americanautowire.com 856-933-0801

71-74 Mopar B-Body
Second Design
Instructions

92972928 rev. 0.0 3/24/2020

Template for modification of the firewall on a 1971-74 Mopar B-body Classic Update Kit

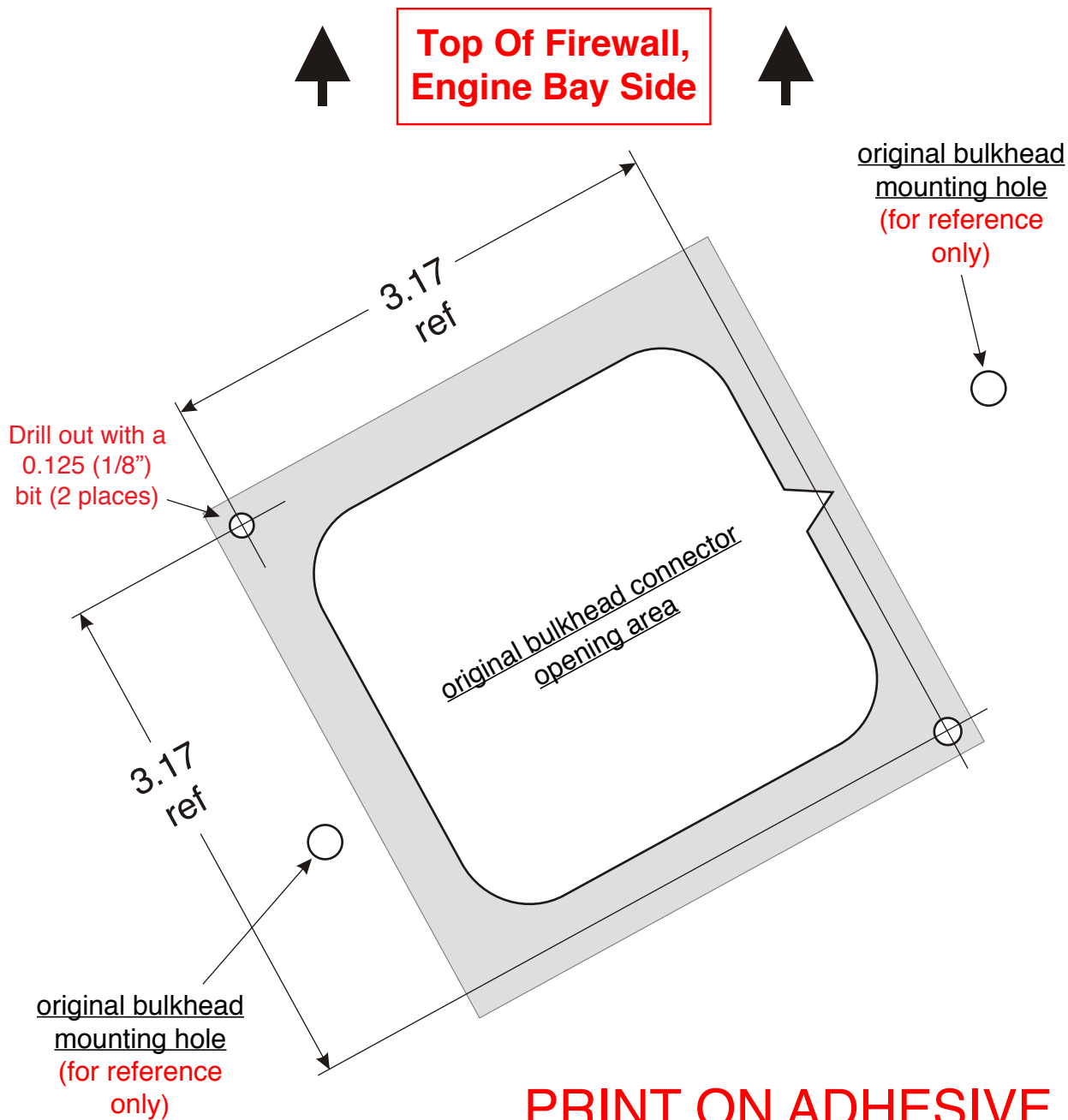

The only firewall modification needed with this new kit is to drill 2 new **0.125 (1/8")** mounting holes. The original opening in the firewall is already the proper size for the new bulkhead connector assembly to fit through. This template can be affixed directly to the Engine Bay side of the firewall (**see page 2 for passenger compartment drilling**) or it can be applied to a stiff piece of cardboard or thin plastic, then mounted to the firewall. Be sure to clean any wax, grease, or oil from the area so that the template will stick.

1. Remove the white "original bulkhead connector opening area" from the template and align this open area with the original firewall opening. You can also use the original mounting holes to help locate this template more precisely.
2. Mark the 2 screw holes that need to be drilled out, onto the firewall using a marker or by other similar means.
3. Using a center punch, slightly dimple the 2 screw marks that you have transferred onto the firewall so that your drill will not walk when making the new holes. Re-check your 2 marked areas with the template to be sure that they are correct, before drilling the 2 new holes.
4. Drill your new mounting holes.
5. Using the provided (2) self tapping screws found in the loose piece kit for the **510692** dash harness, affix the bulkhead connector assembly of the new dash harness into the firewall from up under the dash, inside of the car.
6. Your mounting procedure is now complete. You may now continue with the installation of your new Dash harness.

PRINT ON ADHESIVE LABEL SHEET

92971839

Rev 2.0 1/28/2019

Template for modification of the firewall on a 1971-74 Mopar B-body Classic Update Kit

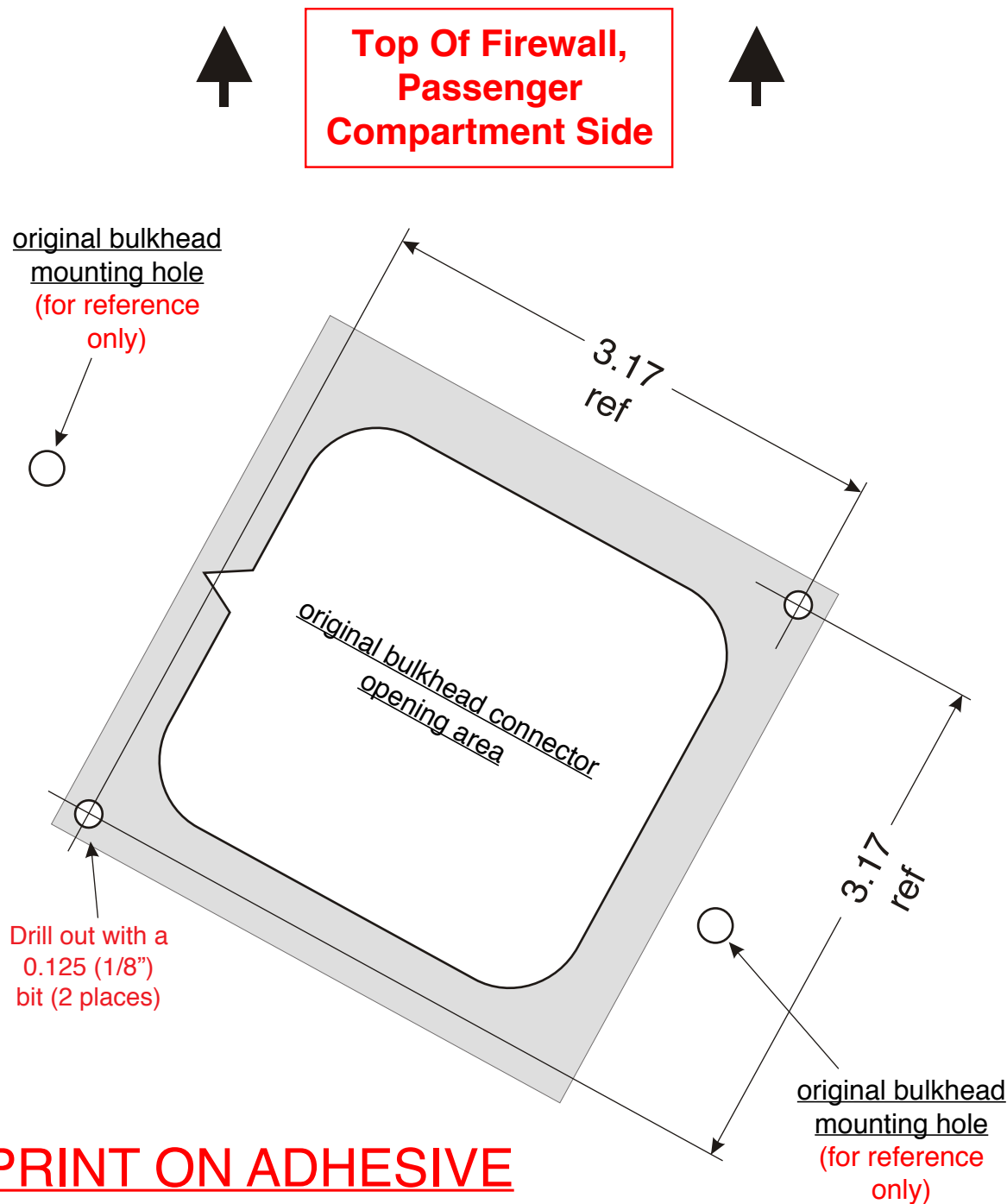

The only firewall modification needed with this new kit is to drill 2 new **0.125 (1/8")** mounting holes. The original opening in the firewall is already the proper size for the new bulkhead connector assembly to fit through. This template can be affixed directly to the passenger compartment side of the firewall (**see page 1 for engine bay drilling**) or it can be applied to a stiff piece of cardboard or thin plastic, then mounted to the firewall. Be sure to clean any wax, grease, or oil from the area so that the template will stick.

1. Remove the white "original bulkhead connector opening area" from the template and align this open area with the original firewall opening. You can also use the original mounting holes to help locate this template more precisely.
2. Mark the 2 screw holes that need to be drilled out, onto the firewall using a marker or by other similar means.
3. Using a center punch, slightly dimple the 2 screw marks that you have transferred onto the firewall so that your drill will not walk when making the new holes. Re-check your 2 marked areas with the template to be sure that they are correct, before drilling the 2 new holes.
4. Drill your new mounting holes.
5. Using the provided (2) self tapping screws found in the loose piece kit for the **510692** dash harness, affix the bulkhead connector assembly of the new dash harness into the firewall from up under the dash, inside of the car.
6. Your mounting procedure is now complete. You may now continue with the installation of your new Dash harness.

PRINT ON ADHESIVE LABEL SHEET

92971839
Rev 2.0 1/28/2019



WARNING:

Validate the kit contents with the component list included on this page before proceeding. This kit is intended to be used in a modified vehicle. Please read this page thoroughly and be sure that you understand everything explained on it prior to opening any of the enclosed packages, or before attempting to install any of the components. Once this kit has been opened or a component installed, the kit is not returnable.

1. This new upgraded AAW wiring system should typically be used in a MODIFIED application only.
2. This kit includes the wiring to support the use of a factory heater only system and/or aftermarket heater and A/C systems. **This kit does not include the wiring for the factory original A/C system.** An optional A/C Kit 510474 is available that will allow you to use your original factory A/C components,
3. There is no wiring in this kit for the electric headlight motors used on the hideaway headlight system, nor does this kit support that system in any way.
4. This kit only supports the use of a higher current, self-exciting 1-wire alternator. **The use of the factory externally regulated alternator is not supported with this kit.**
5. AAW **DOES NOT** support the use of an ammeter. All AAW kits are engineered to supply the optimum charge to the battery. To achieve this performance, we route our 6 gauge charge wire from the alternator output charge terminal to the starter relay battery terminal. Due to the path of the charge being altered from the stock configuration, the gauge can no longer see a charge vs. discharge. This wiring system has been designed to work with a voltmeter.
6. This kit **IS NOT** set up with a resistance wire for a standard, points type ignition system. It is wired with a full 12-volt primary ignition feed. See **pages 27 and 28** for the various Ignition System Wiring configurations.

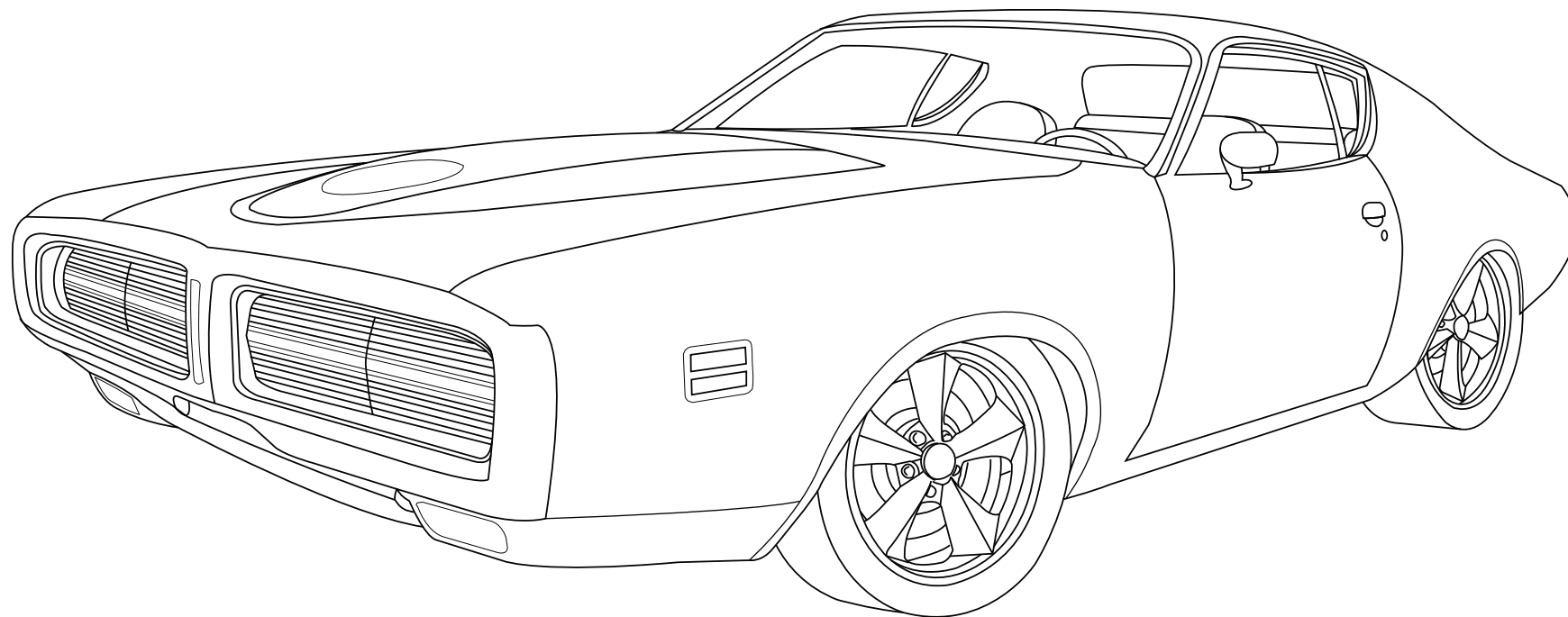

510691 - Classic Update Series Kit 1971-74 MOPAR B-Body

This kit contains the following components:

Bag	Part Number	Description	Quantity
	500042	Floor Dimmer Switch	1
	510698	Headlight Switch	1
	510697	Fuse, Relay, and Flasher kit	1
	500919	Practice Terminal Crimping Set	1
G	510787	Dash Harness kit	1
H	510788	Instrument Cluster wiring kit	1
J	510786	Engine Wiring Kit	1
L	510695	Front Light Wiring kit	1
M	510696	Rear Body Wiring kit	1
V	510730	VSS Connection Kit	1
Z	510476	Alt. & Main Power Connection Kit	1
	92971839	Bulkhead Connector Mtg Template	1

Validate the kit contents with this component list. If there are any discrepancies with incorrect or missing parts, stop your installation and notify the supplier you purchased the kit from before proceeding.



www.americanautowire.com 856-933-0801

1971-74 MOPAR B-Body

Classic Update Series

510691

© COPYRIGHT 2004 American Autowire / Factory-Fit
Used with express permission of
American Autowire / Factory-Fit
92972832 Rev 2.0 3/15/2023

START HERE !

PLEASE READ THIS BEFORE STARTING INSTALLATION !

This wiring kit is designed for ease of installation. Please read the guidelines below, BEFORE STARTING your installation, to guarantee a successful job. Use an appropriate crimping tool, which folds the wings of the open barrel terminals down into the wire, as shown on this page. If you use our crimping tools and correctly crimp the included terminals, soldering is not necessary. If you are unsure about a particular crimp, soldering is recommended. Our factory crimped terminations are installed by GM approved five ton presses, and soldering these terminations is not necessary



AAW offers a great terminal crimping video entitled "Proper Crimping Video". It can be viewed by visiting YouTube.

Type the following address into your web browser, to go directly to the video:

www.youtube.com/watch?v=JAgEDoVI-co

YouTube Channel:

www.youtube.com/user/WiringHarness



The terminals that we supply in our kits, utilize what is known as an F crimp. The F crimp, in a cross section, will look like the illustration below, when done correctly.

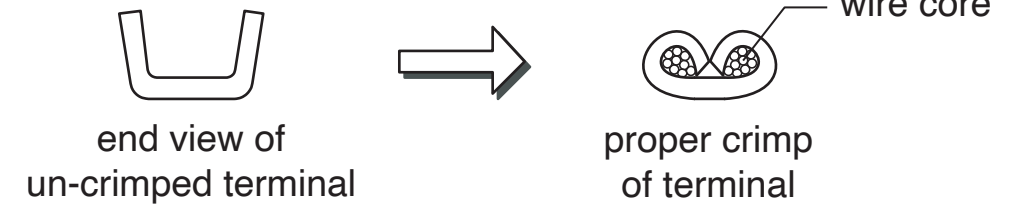

We carry the following crimping hand tools, to help with your terminal crimping. These hand tools are available, for purchase or rental.



We carry many accessories for your 1971-74 MOPAR B-Body:



p/n 500479
Universal Relay Kit



p/n 510474
A/C Overlay Wiring Kit



p/n 500235
Billet Aluminum Knob
(fits a 1/4" shaft)
(use on wiper switch)



p/n 500093
Universal Waterproof Relay Kit



www.americanautowire.com 856-933-0801

If you have any questions concerning this or any of our products, please feel free to call us at 1-856-933-0801.

1971-74 MOPAR B-Body

Classic Update Series

510691 92972832 Rev 2.0 3/15/2023

STEP 1: DISCONNECT YOUR BATTERY

Disconnect the battery before installing the wiring kit. This is to prevent any accidental shorting caused by bare wire ends.

STEP 2: LOAD THE FUSE BLOCK

Prior to installing the Dash harness to the dash, obtain the Fuse, Flasher, and Relay Kit 510697 and plug all of the fuses and the flashers to the Fuse Block (see below). Plug the Horn Relay to the Dash harness (see below).

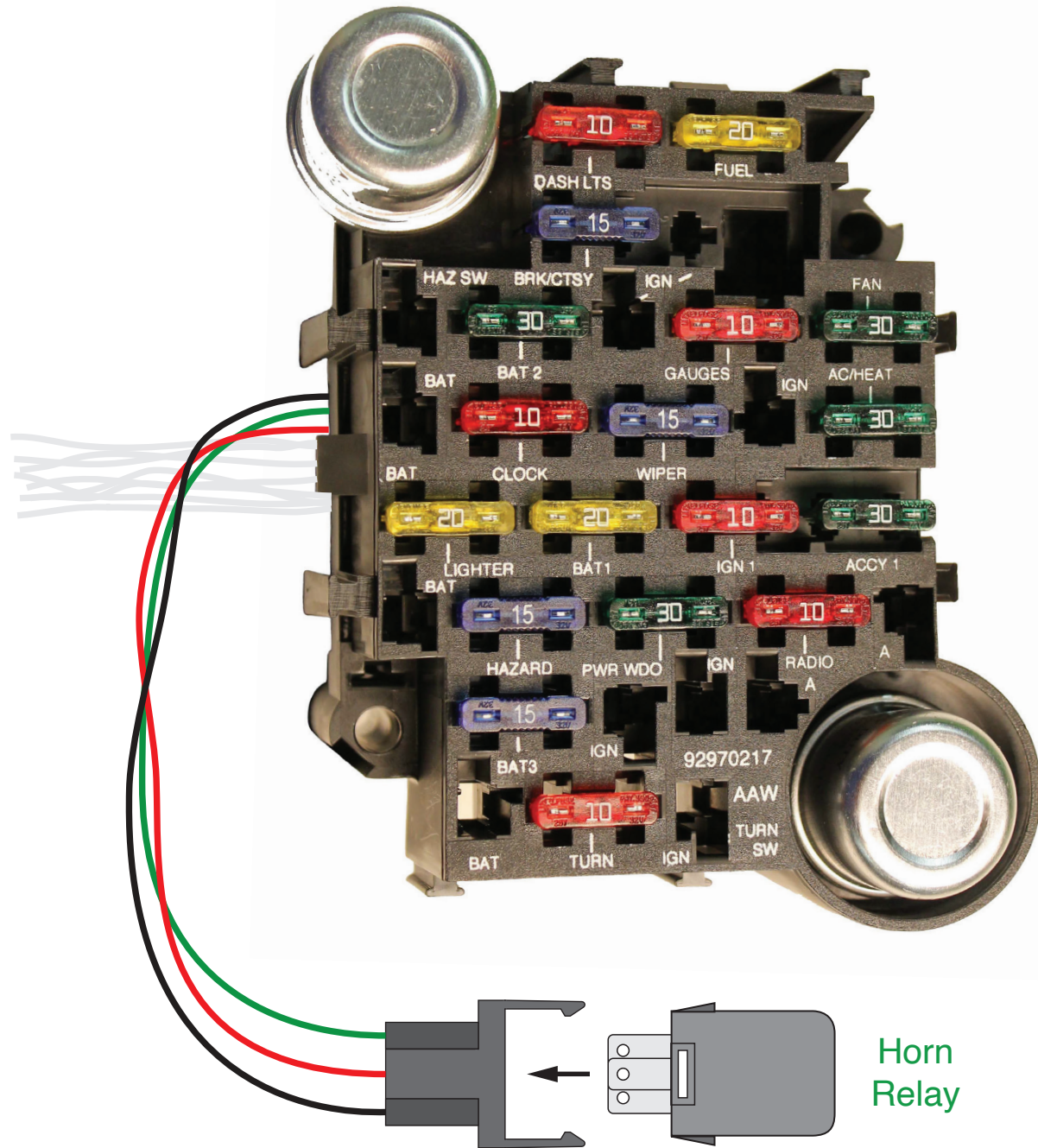

Fuse usage details

Fuse #	Fuse Block Printing	Fuse Rating	System Wiring Protected
1	DASH LTS	10A	Cluster lights, any dash illumination lights.
2	FUEL	20A	Electric fuel pump, electric speedo power (Accy 6-way conn).
3	BRK/CTSY	15A	Stop lights, courtesy lights, dome light, battery feed in Rear Body (trunk light), map light, tail lights and park lights.
4	BAT 2	30A	Power seats (Accy 6-way conn).
5	GAUGES	10A	Oil pressure warning light, brake warning light, backup lights, reverse warning light and optional tachometer.
6	FAN	30A	Electric fan.
7	CLOCK	10A	Clock, radio battery feed.
8	WIPER	15A	Wiper.
9	AC/HEAT	30A	Air conditioning/heater feed.
10	LIGHTER	20A	Lighter.
11	BAT 1	20A	Power locks (Accy 6-way conn).
12	IGN 1	10A	Electric choke.
13	ACCY 1	30A	Accessory feed for options (Accy 6-way conn).
14	HAZARD	15A	Hazard lights.
15	PWR WDO	30A	Power windows (Accy 6-way conn).
16	RADIO	10A	Accessory feed for radio.
17	BAT 3	15A	Battery feed for options (Accy 6-way conn).
18	TURN	10A	Turn signals.

STEP 3: PREPARING TO INSTALL THE DASH HARNESS

Remove the dash frame assembly from the vehicle. You be installing the harness onto it.

STEP 4: DRILL THE FUSE BLOCK MOUNTING HOLES

Obtain the Bulkhead Mounting Template 92971839 and drill the two 1/8" holes in the firewall. This will prep the firewall so that it's ready to accept the new dash harness and Fuse Block/Bulkhead Assembly. Note that the mounting template can be used from either inside the passenger compartment, or outside in the engine compartment. Verify that the new holes in the firewall are in alignment with the Fuse Block/Bulkhead Assembly by positioning the Fuse Block/Bulkhead Assembly in the firewall. Insert the self tapping screws "M" (see page 5), into the Fuse Block/Bulkhead Assembly to make sure the threaded portion aligns with the new holes in the firewall. Do not permanently attach the Fuse Block/Bulkhead Assembly to the firewall until after the dash frame/Dash Harness assembly is installed in the vehicle.

STEP 5: INSTALL THE CLIPS AND J-CLAMPS

Obtain the two 1" wraparound clips item "D" and install to the dash near the speaker opening (see page 12). Obtain the 3 J-Clamps item "R" (see page 12) and attach to the existing dash pad studs.

STEP 6: START INSTALLING THE KIT

This kit is broken down into individual sections that are identified by a letter printed on the enclosed sheets, visible through each bag. The order of installation and the pages with their installation instructions are shown on page 4:



Table of Contents:



**American
Autowire**

www.americanautowire.com 856-933-0801

Bags: Pages: Sections:

G 5-11 Dash Harness (Part 1 Installation) – This is the main harness in the kit and it should first be installed to the dash frame assembly. Install the main trunk of the Dash Harness in the original factory trough. The Dash Harness contains:

Instrument Cluster Harness connections	Map Light connection	Wiper Switch connections
Headlight Switch connections	Heater Overlay Harness (Item T) connection	Heater Switch Control Assembly connections
Courtesy Light connections	Ground connection	Radio wires
Cigar Lighter connection	Ash Tray Light connection	Reverse Warning Light connection
Heater Blower Resistor connection	Glove Compartment Light connection	Electric Speedometer Ground connection

Dash Harness (Part 2 Installation) – After installing the Dash Harness to the dash frame assembly, now install the entire assembly back into the vehicle. Attach the Fuse Block/Bulkhead Assembly to the firewall. The Dash Harness now connects to the following components:

Ignition Switch	Turn Signal Switch
Stop Light Switch	Manual Transmission Clutch Switch
Rear Body Harness	Dome Light Harness
LH & RH Door Jamb Switches	Park Brake Switch
Dimmer Switch	Heater Blower Resistor

H 12-16 Instrument Cluster Harness – This harness is assembled by the customer and connects to:

Non-Rallye Cluster

Printed Circuit Board (PCB)
Clock
Tachometer

Rallye Cluster

Constant Voltage Regulator (CVR)
Brake Warning Light
High Beam Indicator Light
Ground
Tachometer

Dash Illumination Lights
RH and LH Indicator Turn Lights
Gas, Oil, and Temperature Gauges
Clock

1971-74 MOPAR B-Body

Classic Update Series

510691 92972832 Rev 2.0 3/15/2023

12 Aftermarket Gauges
All gauges

M 17-18 Rear Body Harness –This harness connects to:

Dash Harness	Dome Light Pigtail	Rear Door Jamb Switches (4-door)
Third Brake Light	Fuel Tank Sender	Trunk Light
Original Tail Light Harness	Rear Side Markers	

L 19-22 Front Light Harness –This harness connects to:

Bulkhead Connector	Wiper Motor	Brake Warning Switch
Electric Fan (requires an optional Relay Kit)	LH Headlights	LH Park/Turn Signal, Side Marker, Fender Top Turn Signal Lights
Horns	RH Headlights	RH Park/Turn Signal, Side Marker, Fender Top Turn Signal Lights
Washer Reservoir		

J 23-28 Engine Harness –This Harness connects to:

Back-up Light Switch, Neutral Safety Switch	Ignition System	Electric Choke, Oil Pressure and Water Temperature Senders
Alternator	Starter Relay	

510787 Dash/Main harness installation instructions:

Below are the supplied misc. terminals, connector bodies and assorted components included in the Dash/Main Harness and Loose Piece bags. These will be used to complete your Dash/Main harness connections and are referred by the letters and descriptions below from this point forward.

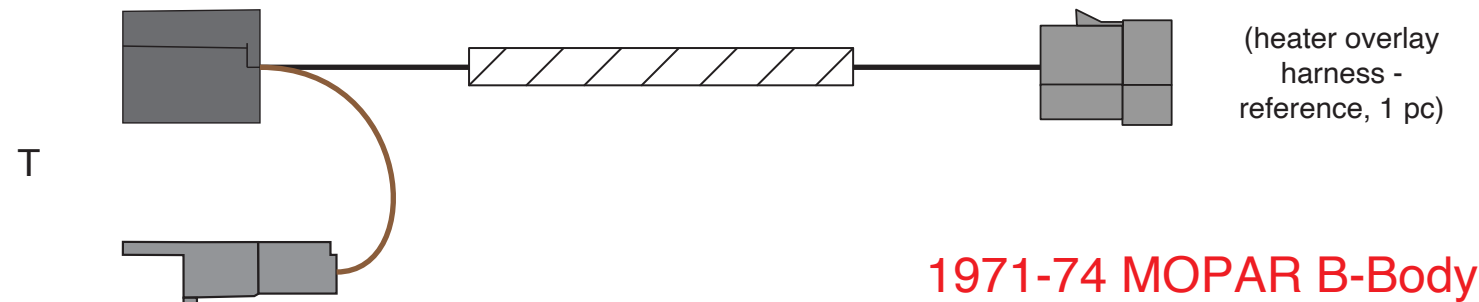
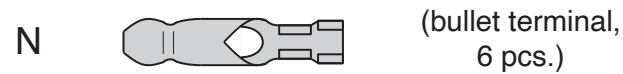
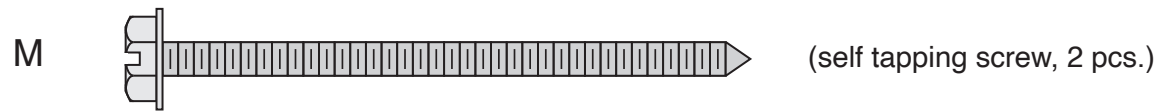
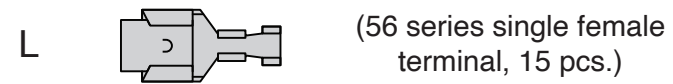
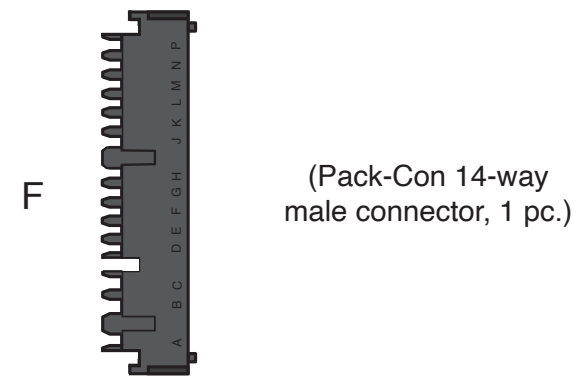
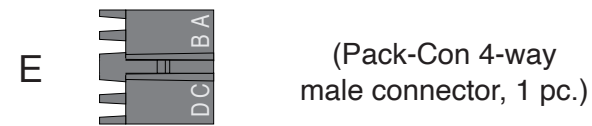
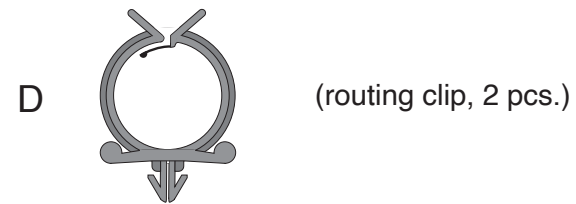
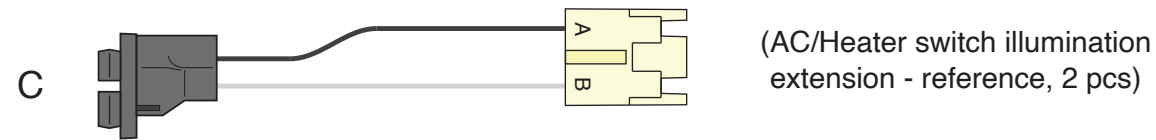
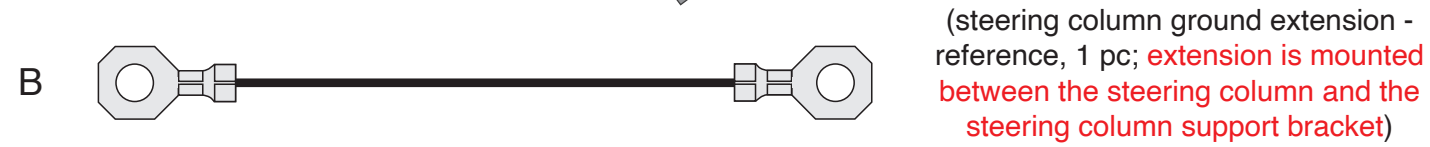
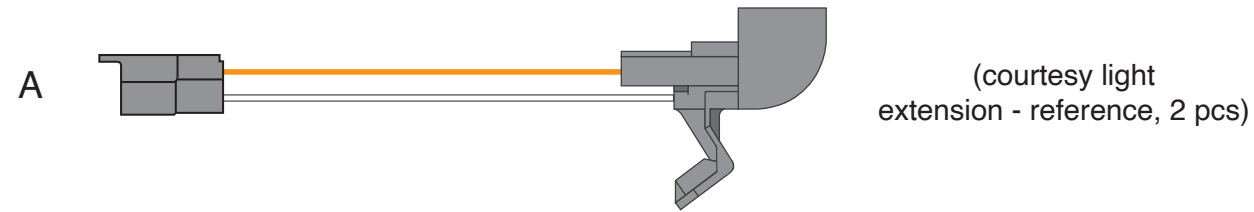

510787 Dash/Main harness installation instructions:

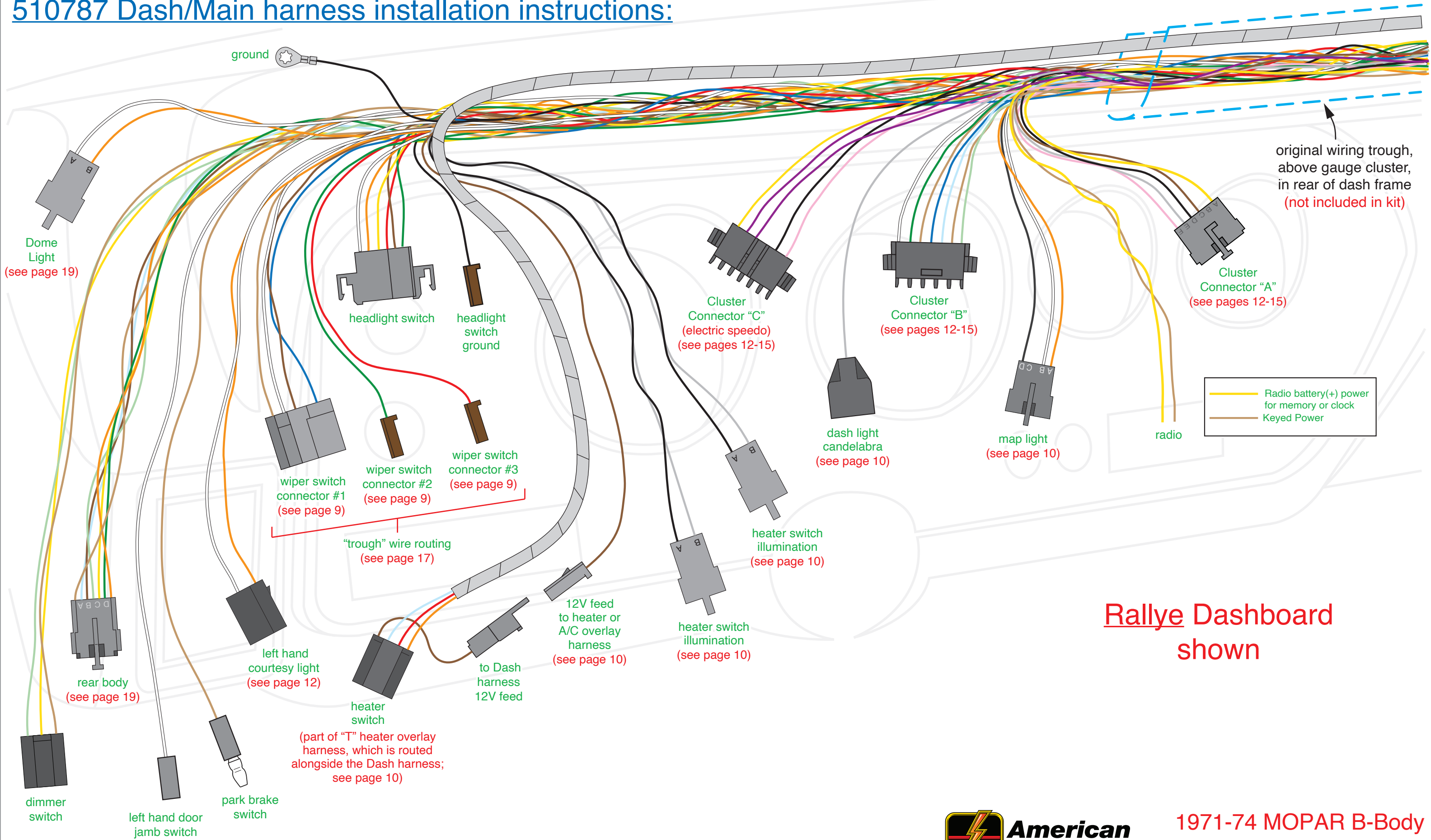

original wiring trough, above gauge cluster, in rear of dash frame (not included in kit)

Radio battery(+) power for memory or clock
Keyed Power

Rallye Dashboard shown



510787 Dash/Main harness installation instructions:

Rallye Dashboard shown

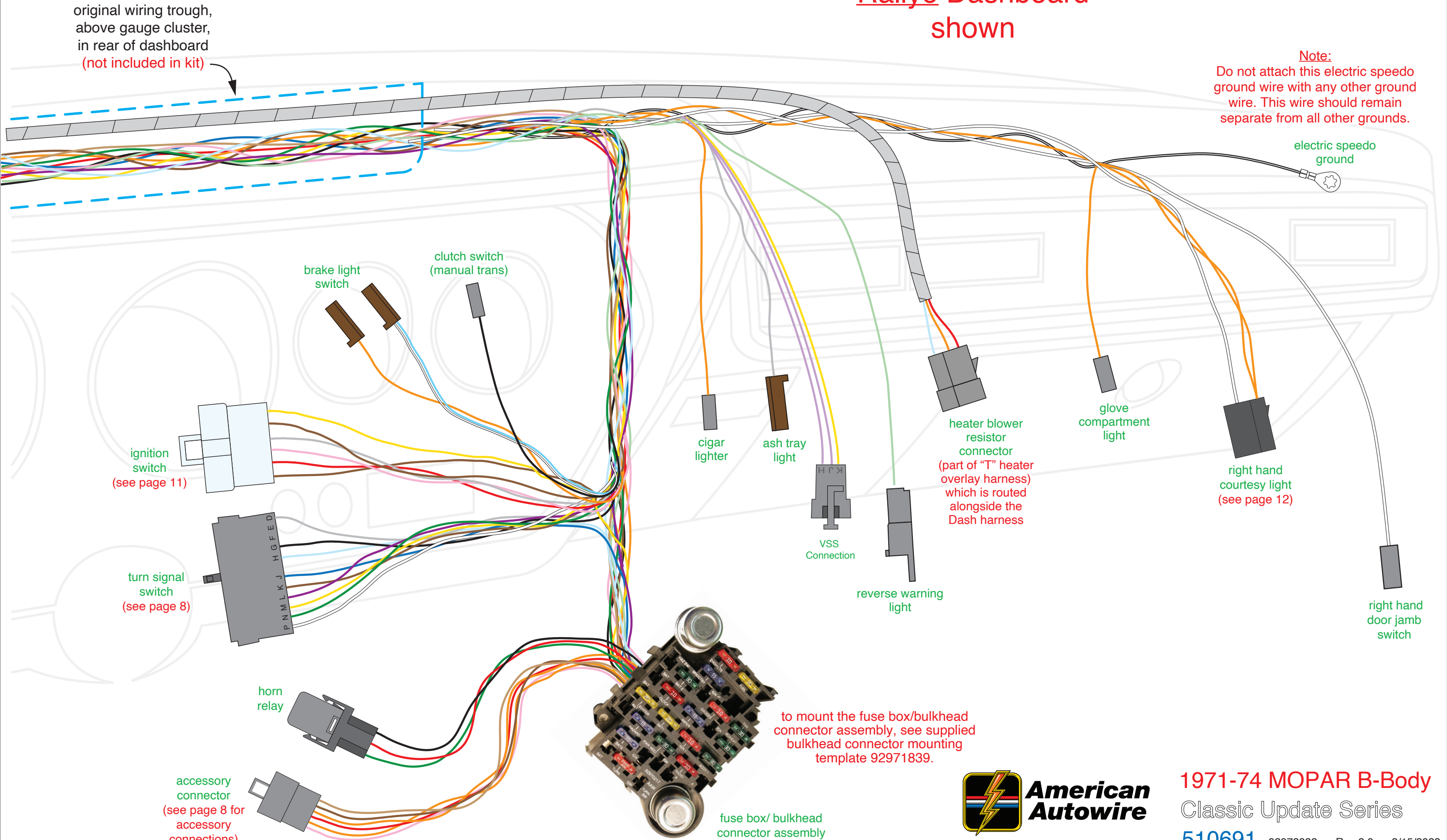

510787 Dash/Main harness installation instructions:

Non-Tilt Steering Column

Tilt Steering Column

“Table B”

“Table C”

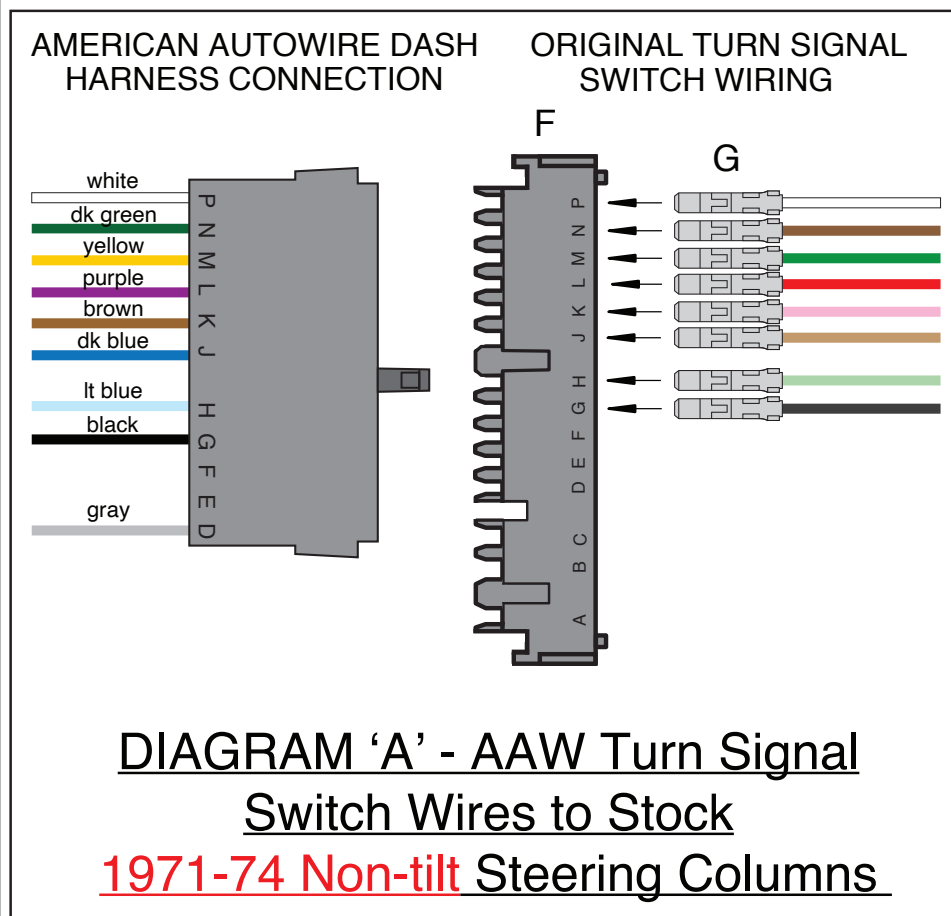

AAW Turn Signal Switch wires to stock 1971-74 MOPAR B-Body Turn Signal Switch (Non-tilt steering column)

AAW Turn Signal Switch wires to stock 1971-74 MOPAR B-Body Turn Signal Switch (Tilt steering column)

AAW Wire Color	AAW Wire Printing	Connector Cavity AAW	B-body Wire Color	Aftermarket Color
White	Brake SW	P	White	White
Dark Green	Right Rear Turn	N	Brown	Dark Green
Yellow	Left Rear Turn	M	Dark Green	Yellow/Black
Purple	Turn Switch Feed	L	Red	Red
Brown	Turn SW – Hazard	K	Pink	Blue
Dark Blue	Right Front Turn	J	Tan	Light Green
Light Blue	Left Front Turn	H	Light Green	Yellow
Black	Horn Relay Ground	G	Black	Green/White
None	None	F	None	None
None	None	E	None	None
Gray	DASH LIGHTS	D	None	None

AAW Wire Color	AAW Wire Printing	Connector Cavity AAW	B-body Wire Color
White	Brake SW	P	Black/White
Dark Green	Right Rear Turn	N	Dark Green
Yellow	Left Rear Turn	M	Black/Yellow
Purple	Turn Switch Feed	L	Purple
Brown	Turn SW – Hazard	K	Brown
Dark Blue	Right Front Turn	J	Dark Blue
Light Blue	Left Front Turn	H	Black/Blue
Black	Horn Relay Ground	G	Black
None	None	F	Pink
None	None	E	Black/Pink
Gray	DASH LIGHTS	D	Gray or none

Note: Remove the original Turn Signal Switch Connector and replace it with the AAW 14-way connector “F”. Crimp on terminal “G” to each of the original Turn Signal Switch wires and plug them into connector “F” (see Parts Kit 92972828).

Plug the AAW Dash Harness 11-way female Turn Signal Switch Connector directly to the original male 14-way Turn Signal Switch Connector (Tilt Steering Column). All of the wires are already aligned. **The above information is for reference only.**

Use “Table B” above to align the wires. The gray DASH LIGHTS wire, in the AAW Connector cavity “D”, can be used to provide 12V to the Ignition Switch Illumination Light or an Illumination Light in an aftermarket Steering Column.

Note: Since the Key-In-Ignition Warning Buzzer wires are not included in the AAW connector (cavities E and F), the wires in the original B-body connector will not mate with any other wires.

Accessory Connector

Use the provided 6-way empty connector, which is attached to the 6-way Accessory connector on the Dash Harness, and terminals “K” and “L” (see Parts Kit 92972828) to add power wires for the following optional systems:

Wire Color	Wire Printing	Fuse Block Printing	Fuse rating	Description
Orange	no printing	BAT3	15A	Fused 12 volt BATTERY feed spare (may also be used to feed power to another battery circuit)
Tan	FUEL PUMP	FUEL	20A	Fused 12 volt IGNITION feed for an electric fuel pump (may also be used to feed power to another ignition circuit).
Orange	POWER SEATS	BAT2	30A	Fused 12 volt BATTERY feed for power seats (may also be used to feed power to another battery circuit).
Red	POWER LOCKS	BAT1	20A	Fused 12 volt BATTERY feed for power locks (may also be used to feed power to another battery circuit).
Pink	POWER WINDOWS	PWO WDO	30A	Fused 12 volt ACCESSORY feed for power windows (may also be used to feed power to another accessory circuit).
Brown	IGNITION SW ACCY	ACCY1	30A	Fused 12 volt ACCESSORY feed for options.



www.americanautowire.com 856-933-0801

1971-74 MOPAR B-Body Classic Update Series

510691 92972832 Rev 2.0 3/15/2023

510787 Dash/Main harness installation instructions:

wiper switch wiring (Rallye & non-Rallye):



www.americanautowire.com 856-933-0801

A* Armature – AAW brown, no printing wire.

B 12V Accessory Feed – AAW white, “WIPER FEED” wire. This wire can also be removed from the connector to be used as a 12v+ power source for an aftermarket wiper system.

B/U - Not Used.

F1* or H* Field #1 – AAW red, no printing wire.

F2* or P2* Field #2 – AAW dark green, no printing wire.

P* or P1* Park – AAW dark blue, no printing wire.

W This is the feed to the Washer Pump, AAW tan, no printing wire. This is an option and the tan wire may not need to be connected.

1971
2-speed
wiper switch

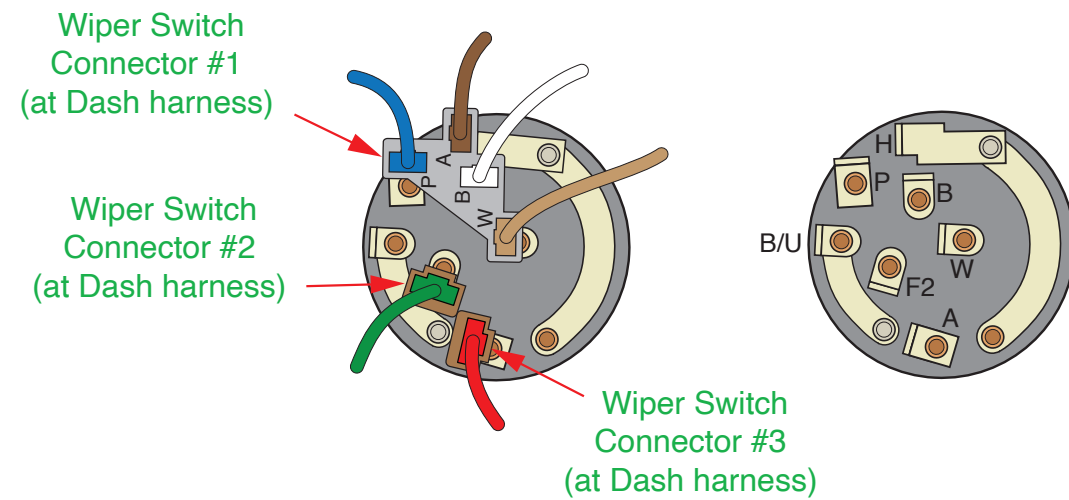

1972-74
2-speed
wiper switch

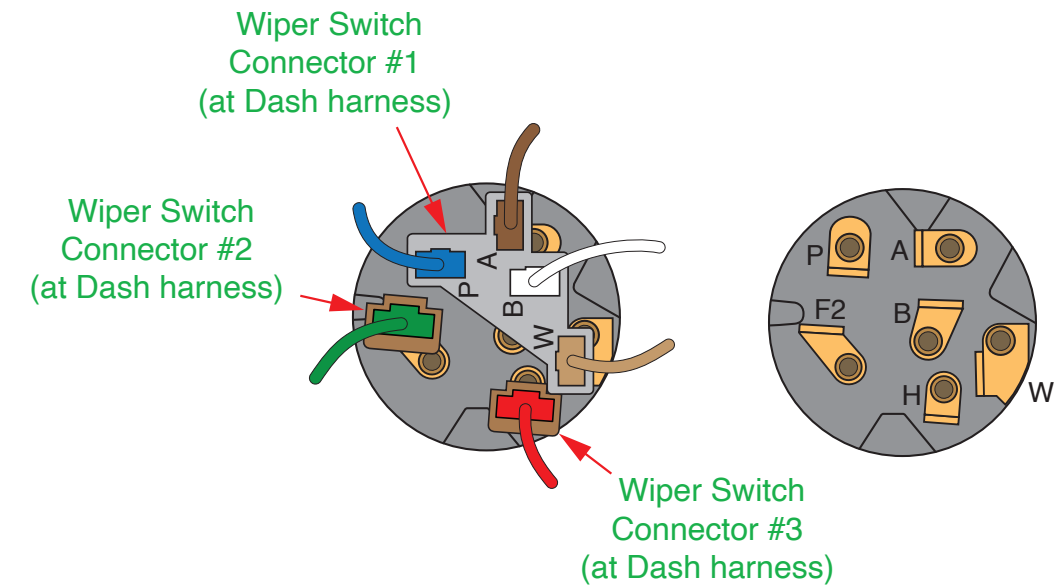

1971
variable-speed
wiper switch

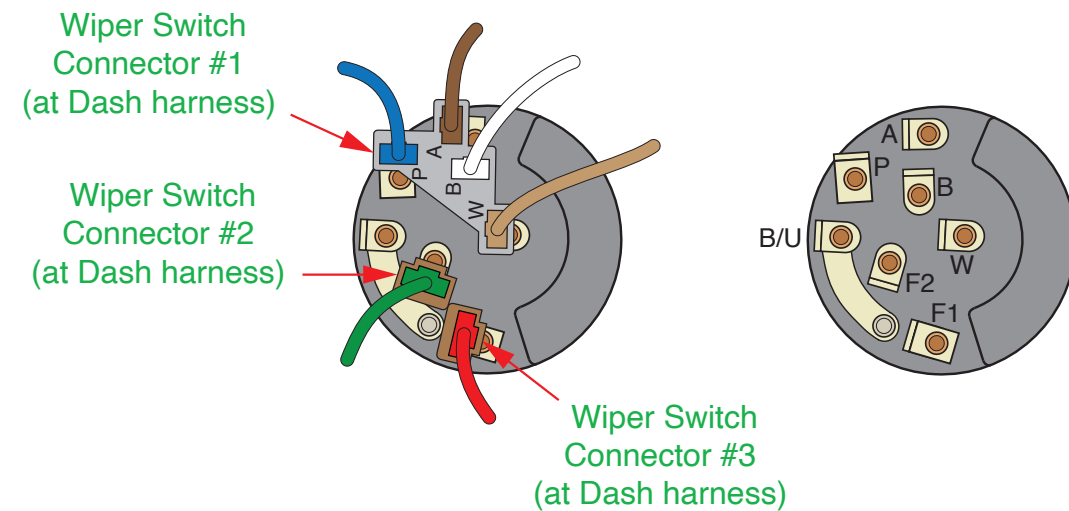

1972-74
3-speed
wiper switch

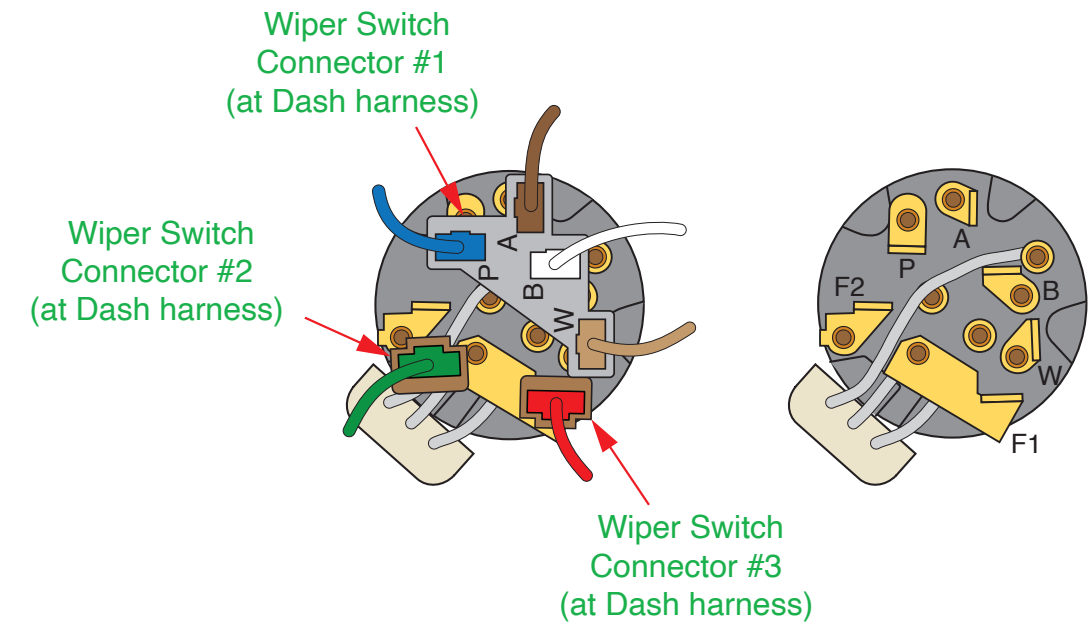

NOTE: To work correctly, switches must be properly grounded. Switches are grounded through their mounting.

1971-74 MOPAR B-Body
Classic Update Series

510691 92972832 Rev 0.0 1/7/2020

510787 Dash/Main harness installation instructions:

map light wiring:

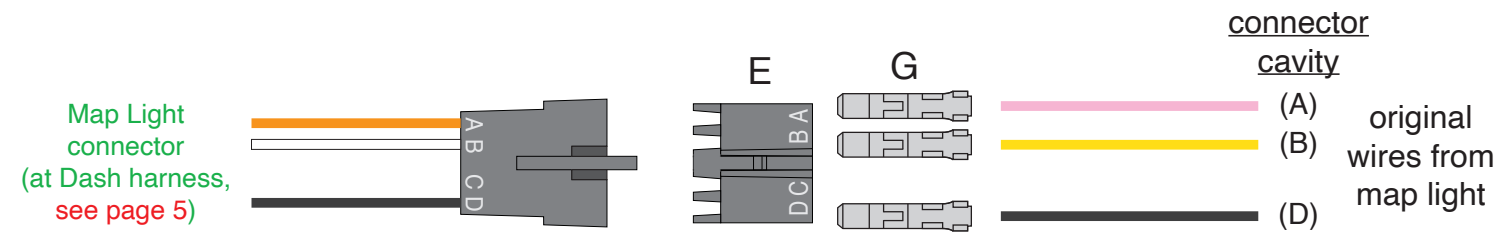

dash light candelabra wiring:

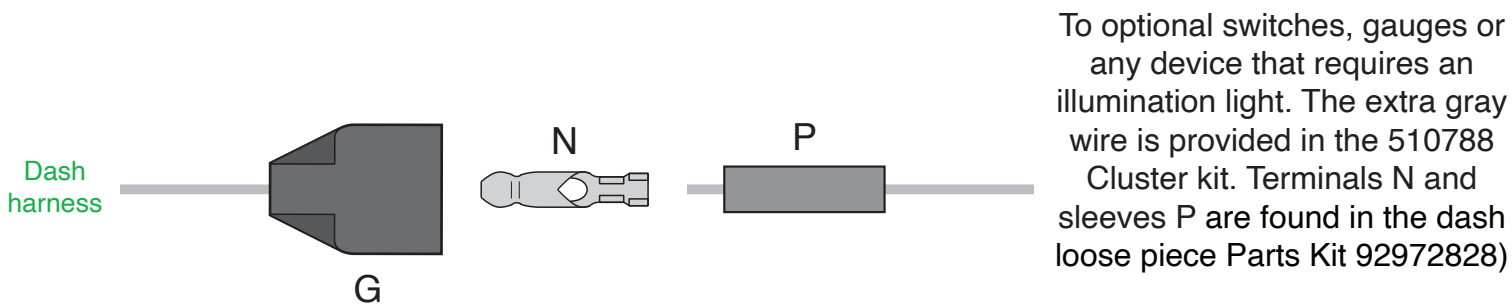

1971-74 MOPAR B-Body
Classic Update Series
510691 92972832 Rev 2.0 3/15/2023

heater only control wiring:

1971-72 Rallye/Non-Rallye Heater only control assembly (top, rear view)

IF YOU HAVE PURCHASED THE 510474 A/C OVERLAY HARNESS, THE "T" HEATER OVERLAY HARNESS AND THE INSTRUCTIONS ON THIS PAGE, WILL BE REPLACED BY THE A/C OVERLAY HARNESS AND INSTRUCTIONS (SEE 510474 A/C KIT INSTRUCTION DRAWING 92972141)

route wires as shown

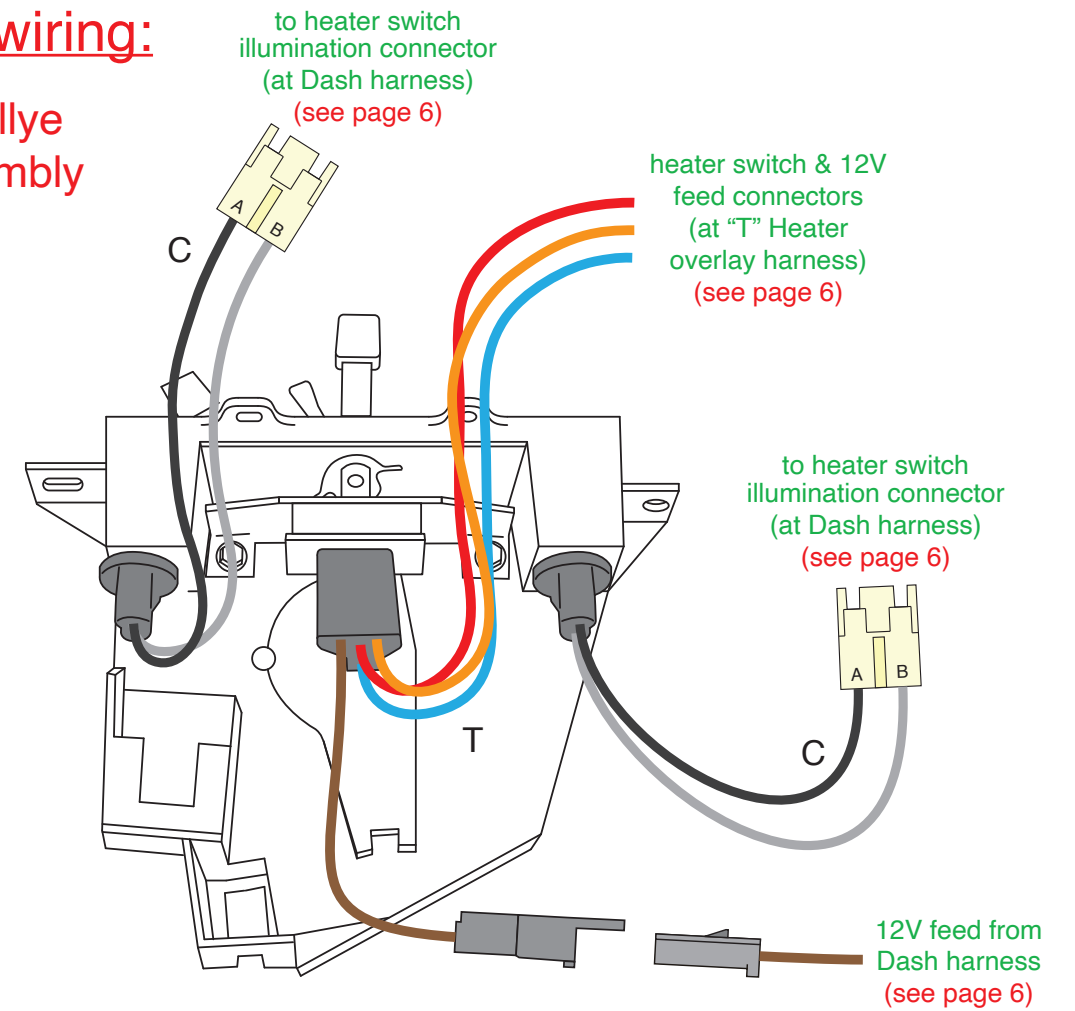

1973-74 Rallye/Non-Rallye Heater only control assembly (top, rear view)

IF YOU HAVE PURCHASED THE 510474 A/C OVERLAY HARNESS, THE "T" HEATER OVERLAY HARNESS AND THE INSTRUCTIONS ON THIS PAGE, WILL BE REPLACED BY THE A/C OVERLAY HARNESS AND INSTRUCTIONS (SEE 510474 A/C KIT INSTRUCTION DRAWING 92972141)

route wires as shown

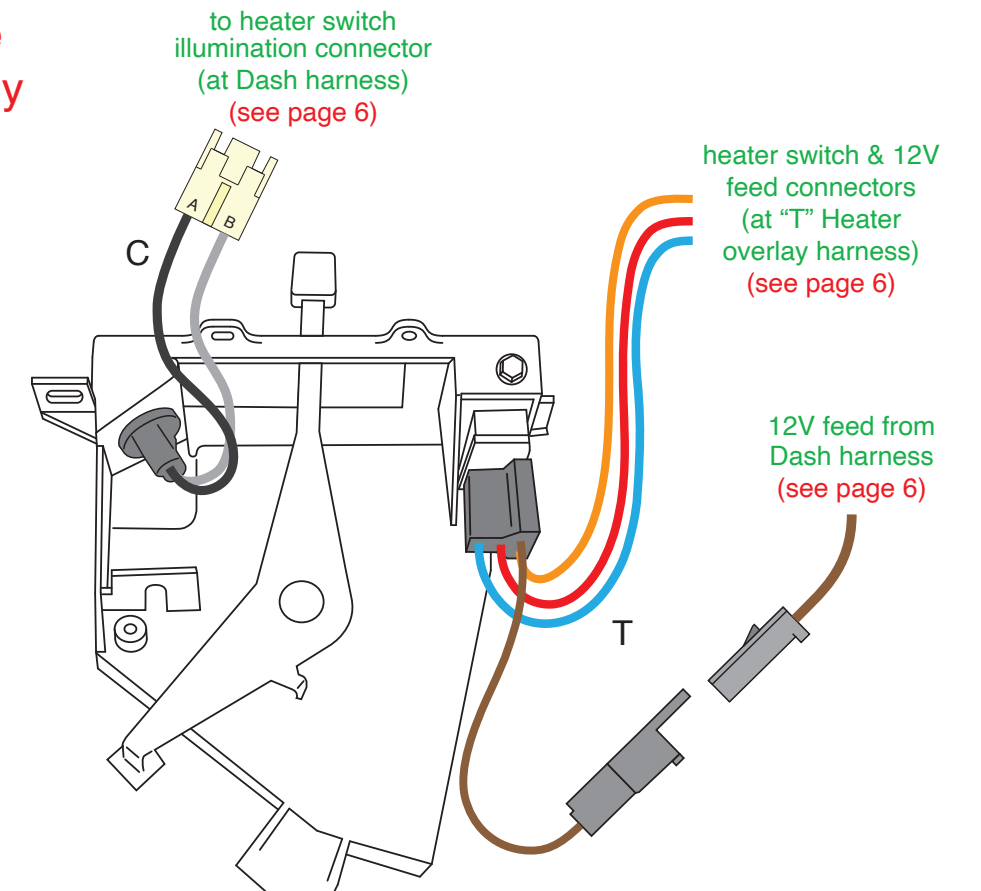

510787 Dash/Main harness installation instructions:

Ignition switch wiring:

Factory MOPAR Column Ignition Switch Connection

Use this diagram to connect to a factory original column-mounted ignition switch.

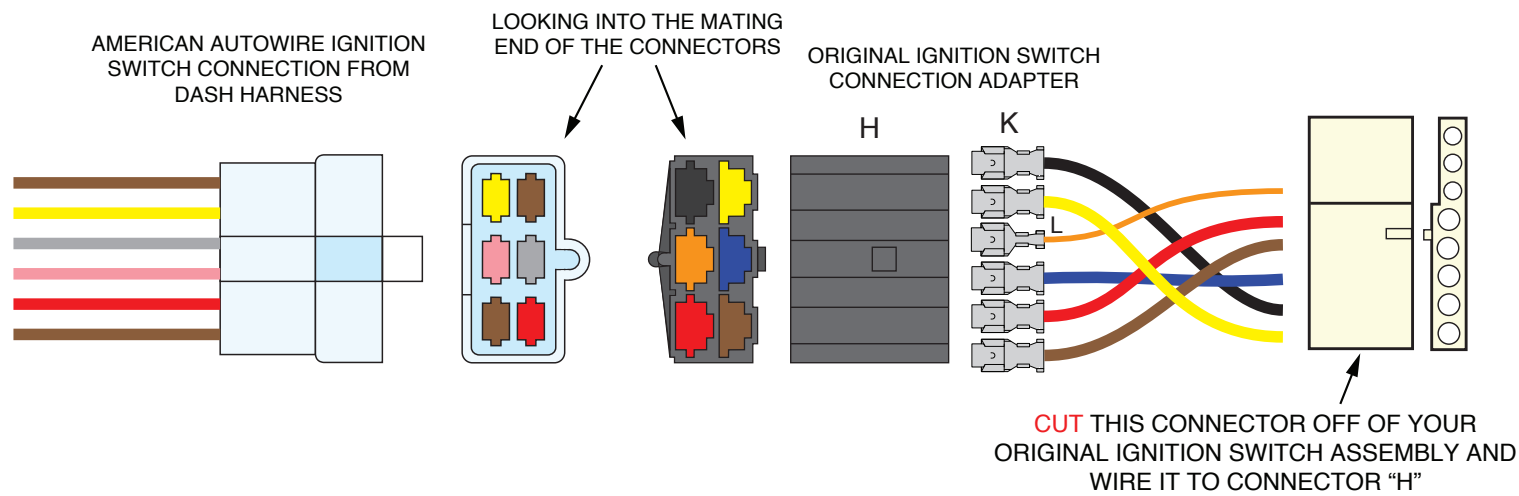

"Table A"

MOPAR B-Body 1971-74 Ignition Switch Wires

AAW Wire Color	AAW Wire Printing	Wire Description	B-Body Wire Color
Yellow	(none)	Start	Yellow
Brown (double)	Ignition switch Accy	12V Accessory Feed	Black
Pink	Ignition feed	Ignition Output 1	Dark Blue
Gray (double)	Dash lights	Column shifter Indicator Light	Orange
Brown	(none)	Ignition Output 2	Brown
Red	12V Battery	12V Battery Feed	Red

Note: Be sure to align the B-Body wire with the corresponding AAW wire in the 6-way connector "H". Crimp on terminal "L" for the thinner wires and terminal "K" for the thicker wires (see Parts Kit 92972828). The two additional thin red wires in the original stock Ignition Switch Connector pigtail, are for the Key-in-Ignition Warning Buzzer and **will not be used** and can be taped back.

Aftermarket GM Style Column-Mounted Ignition Switch Connection

Use this diagram to connect to an aftermarket GM-style column-mounted ignition switch.

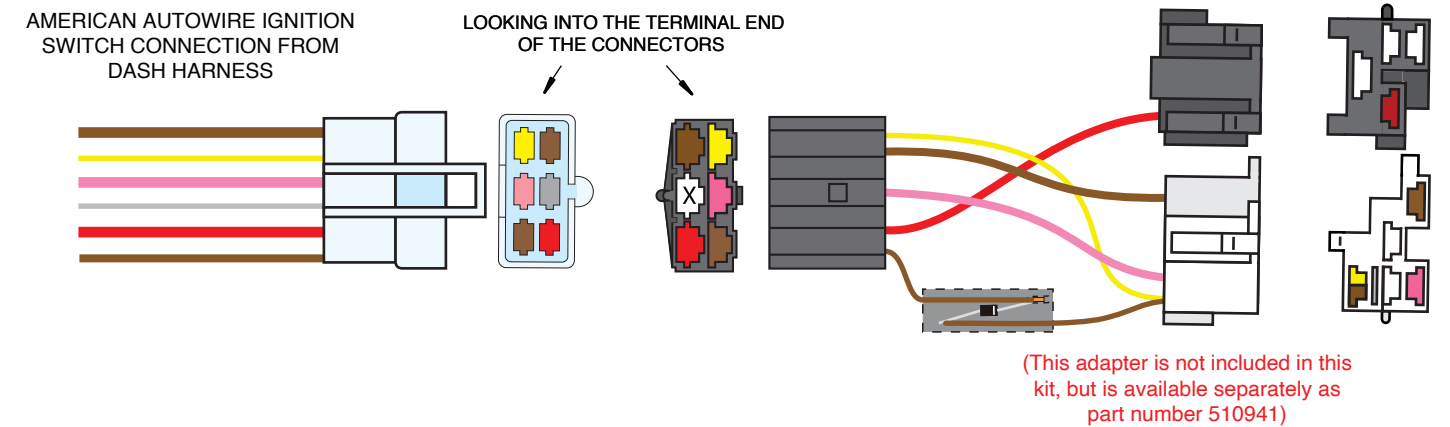

"Table B"

Aftermarket Column Ignition Switch Wires

AAW Wire Color	AAW Wire Printing	Wire Description	AAW Column Adapter Wire Color
Yellow	(none)	Start	Yellow
Brown (double)	Ignition switch Accy	12V Accessory Feed	Brown (heavy)
Pink	Ignition feed	Ignition Output 1	Pink
Gray (double)	Dash lights	Column shifter Indicator Light	Orange
Brown	(none)	Ignition Output 2	Brown (thin)
Red	12V Battery	12V Battery Feed	Red

510787 Dash/Main harness installation instructions:

rear view of the right-hand side of the dash

mount the (3) J-clamps "R" in these locations, above the glove box liner; use the existing studs and nuts that mount the dash pad to the dash

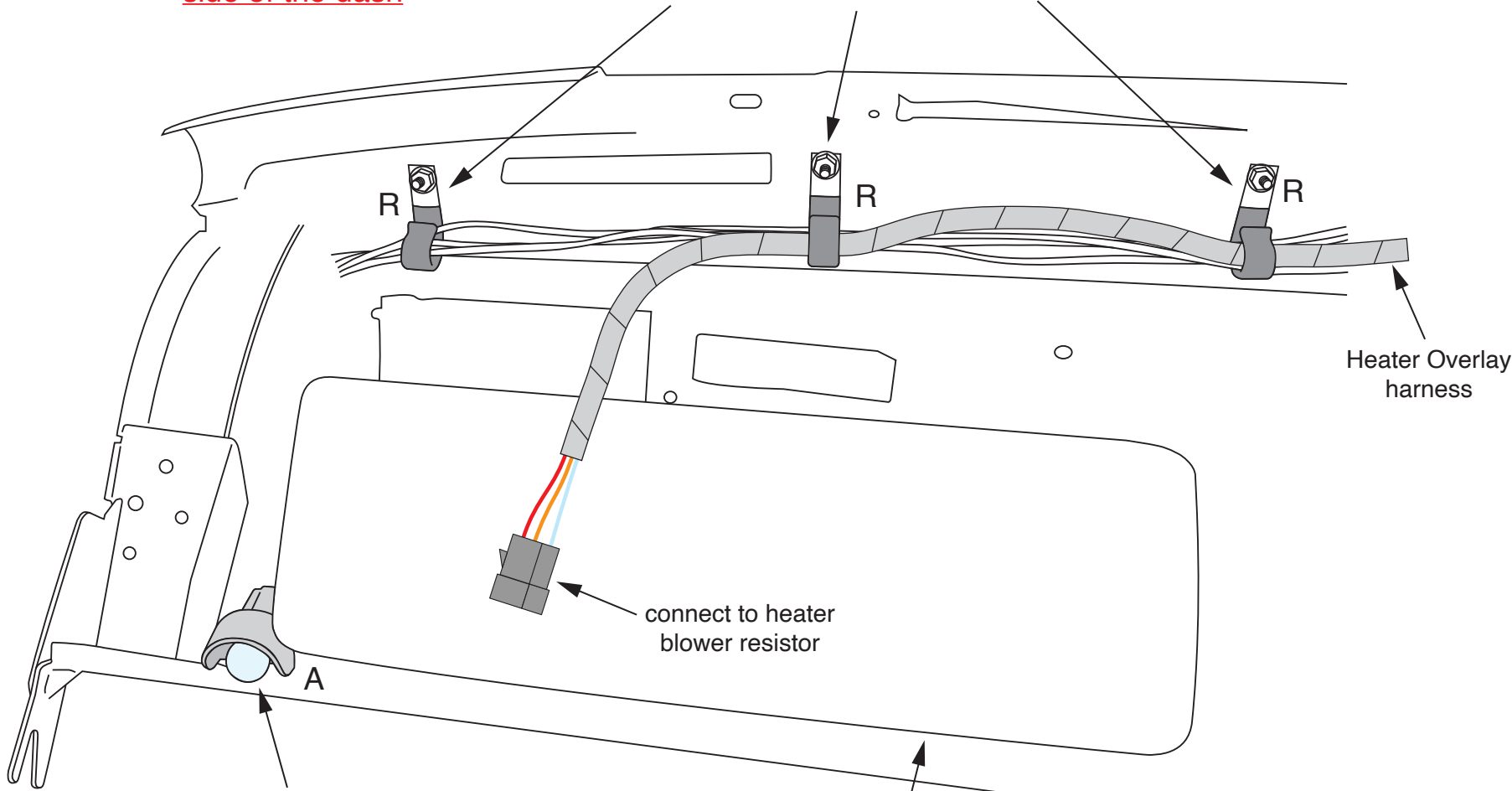

mount the right-hand courtesy light extension "A" in this location, on the lower edge of the right-side of the dash, next to the glove box liner (requires a #631 bulb, **not included in kit**)

glove box liner

rear view of the left-hand side of the dash

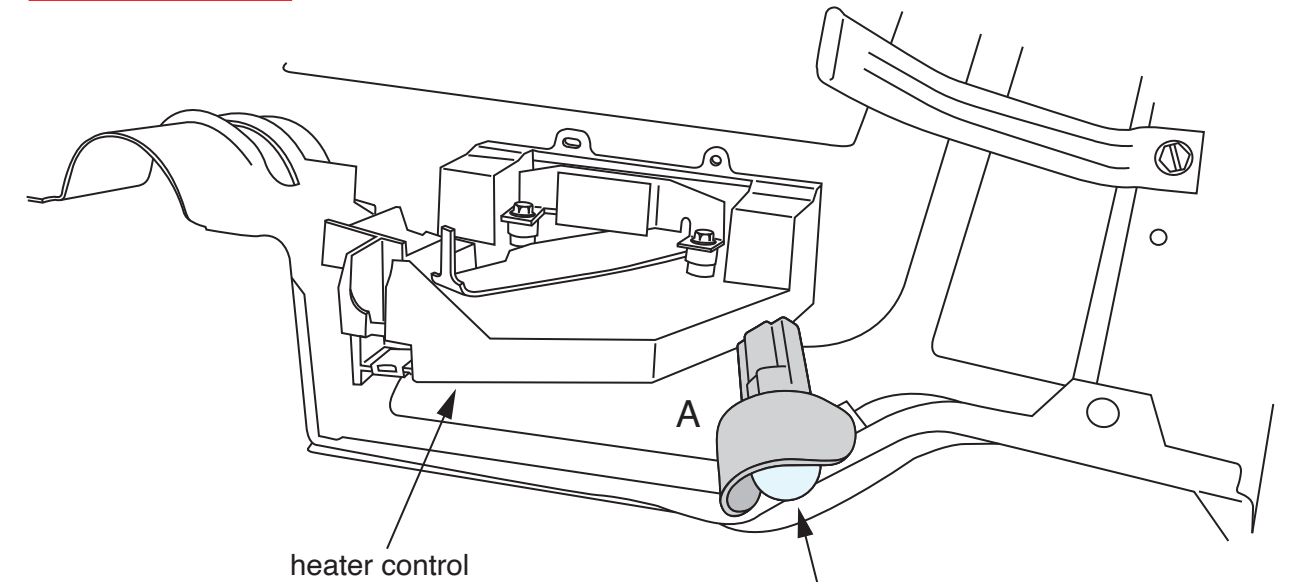

heater control

mount the left-hand courtesy light extension "A" in this location, on the lower edge of the left-side of the dash, near the heater control (requires a #631 bulb, **not included in kit**)

mount the routing clips "D" in these locations, on the upper rear surface of the dash, near the speaker opening

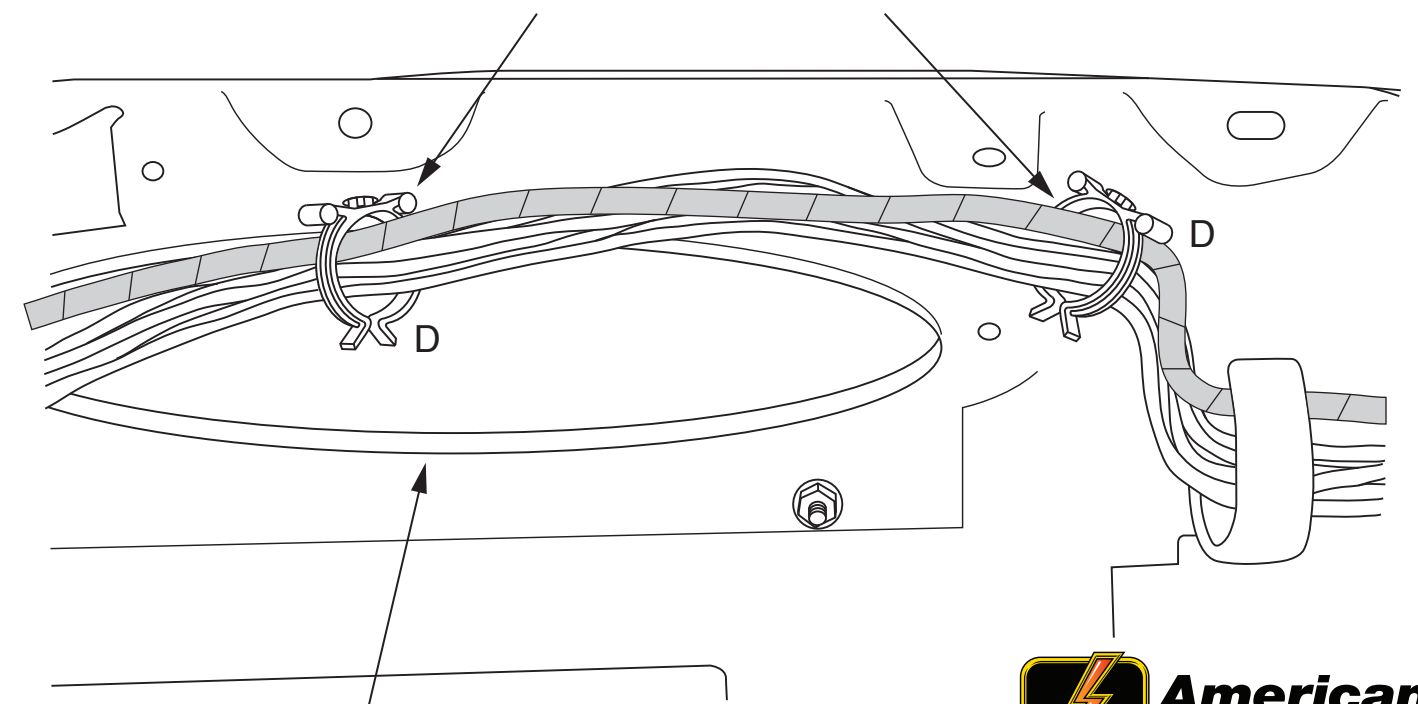

speaker opening

rear view of the center of the dash, near speaker opening

1971-74 MOPAR B-Body
Classic Update Series

510788 Gauge Cluster harness (aftermarket gauges) installation instructions:

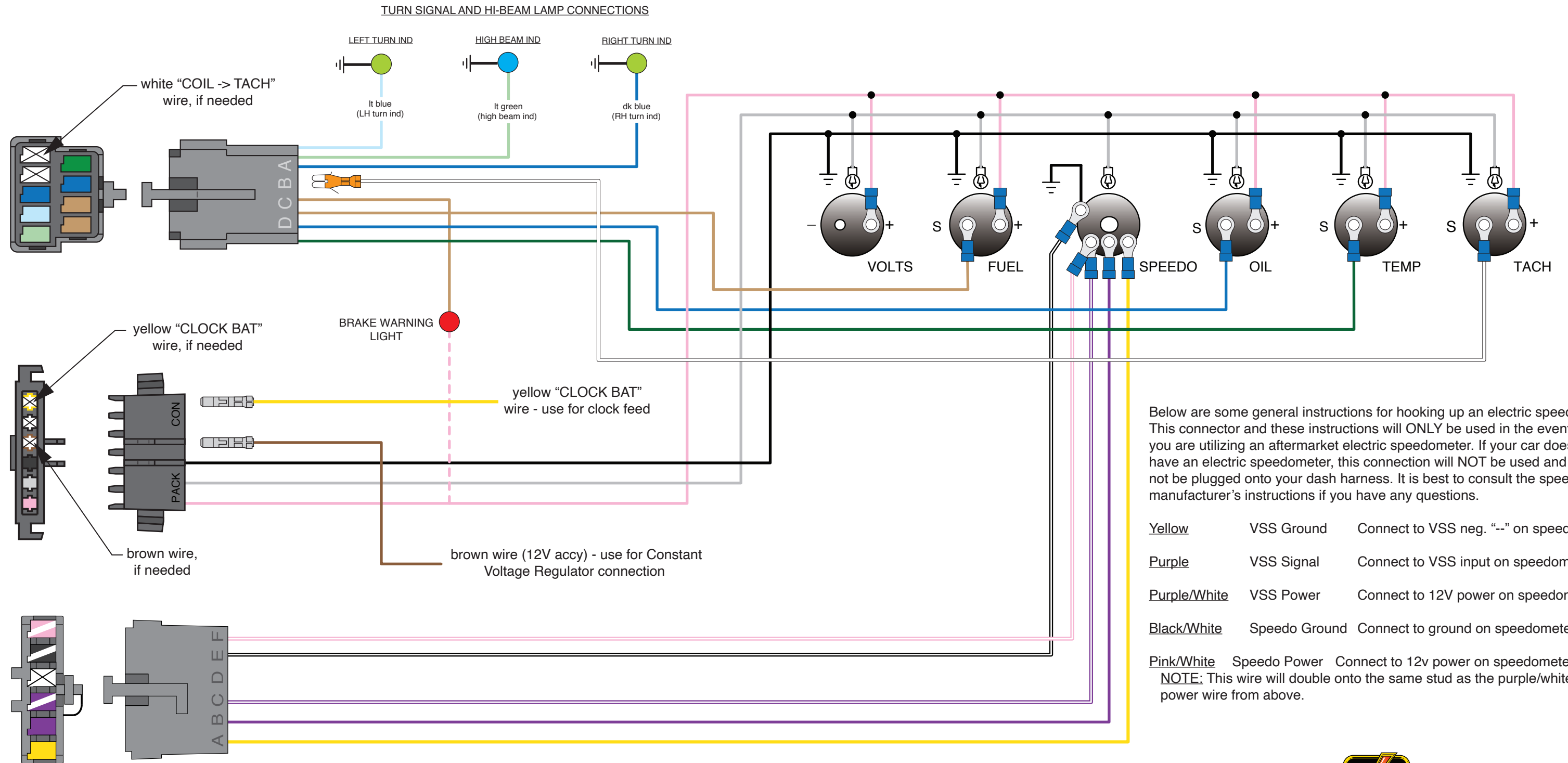

Below are some general instructions for hooking up an electric speedometer. This connector and these instructions will ONLY be used in the event that you are utilizing an aftermarket electric speedometer. If your car does NOT have an electric speedometer, this connection will NOT be used and should not be plugged onto your dash harness. It is best to consult the speedometer manufacturer's instructions if you have any questions.

- Yellow VSS Ground Connect to VSS neg. "--" on speedometer.
 - Purple VSS Signal Connect to VSS input on speedometer.
 - Purple/White VSS Power Connect to 12V power on speedometer.
 - Black/White Speedo Ground Connect to ground on speedometer.
 - Pink/White Speedo Power Connect to 12v power on speedometer.
- NOTE:** This wire will double onto the same stud as the purple/white VSS power wire from above.

For Factory Gauges
See pages 13-15











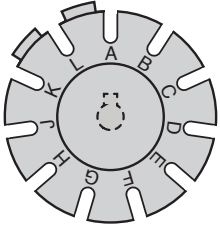
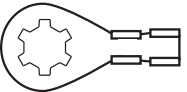

www.americanautowire.com 856-933-0801

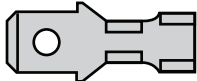
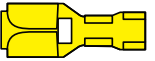
1971-74 MOPAR B-Body
Classic Update Series

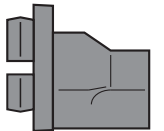
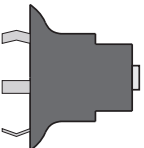
510691 92972832 Rev 2.0 3/15/2023

510788 Gauge Cluster harness installation instructions:

Shown below, are the misc. terminals, plastic connector bodies, sockets, sleeves, and hardware, included in the 510788 Gauge Cluster Loose Piece bag (92972831). These will be used to complete your Gauge Cluster harness connections. They are itemized and referred to on this page just as they are on the following pages of this Gauge Cluster instruction set.

- | | | | | | |
|---|---|--|---|---|----------------------------------|
| A |  | (11-way PCB connector, 1pc) | J |  | (ring terminal, 4 pcs) |
| B |  | (female terminal, PCB connector, 13 pcs) | K |  | (single female connector, 3 pcs) |
| C |  | (male terminal, 1/4", 2 pcs) | L |  | (female terminal, 4 pcs) |
| D |  | (rubber sleeve, 4 pcs) | M |  | (clamp, 2 pcs) |
| E |  | (2-wire light socket, 1 pc) | N |  | (light socket, 11 pcs) |
| F |  | (socket terminal, 16 pcs) | P |  | (splice clip, 3 pcs) |
| G |  | (spring, 2-wire light socket, 2 pcs) | R |  | (locking-nut, 10 pcs) |
| H |  | (terminal, 2-wire light socket, 2 pcs) | S |  | (shrink tubing, 3 pcs) |



1971-74 MOPAR B-Body
Classic Update Series

510691 92972832 Rev 2.0 3/15/2023

How to install light sockets and light socket terminals.

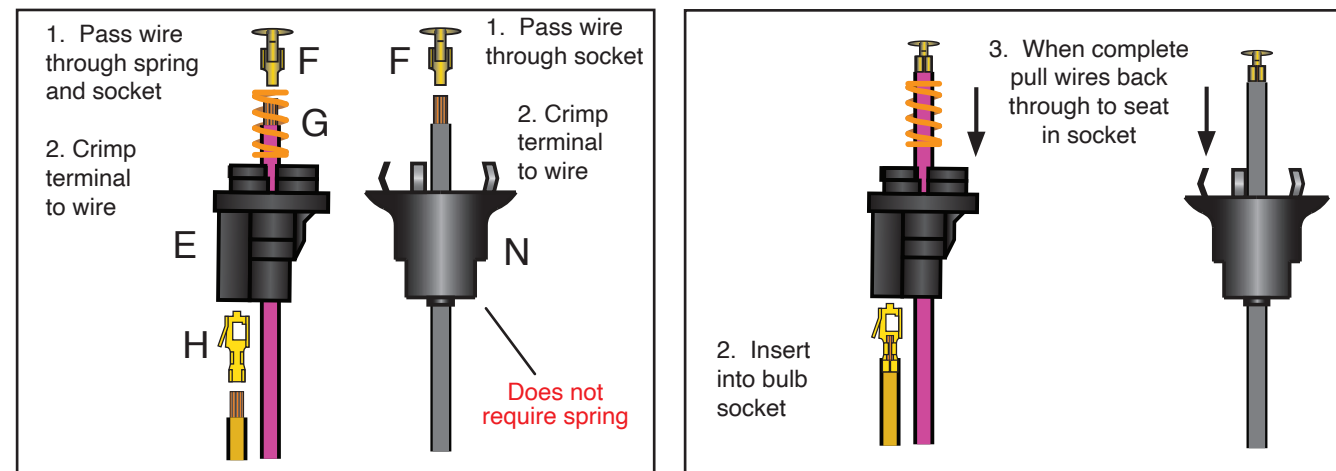

How to use the splice clip to join multiple wires.

Below is just an **EXAMPLE** of how to use the splice clip and shrink tubing; see your specific application on the following pages for actual splice information.

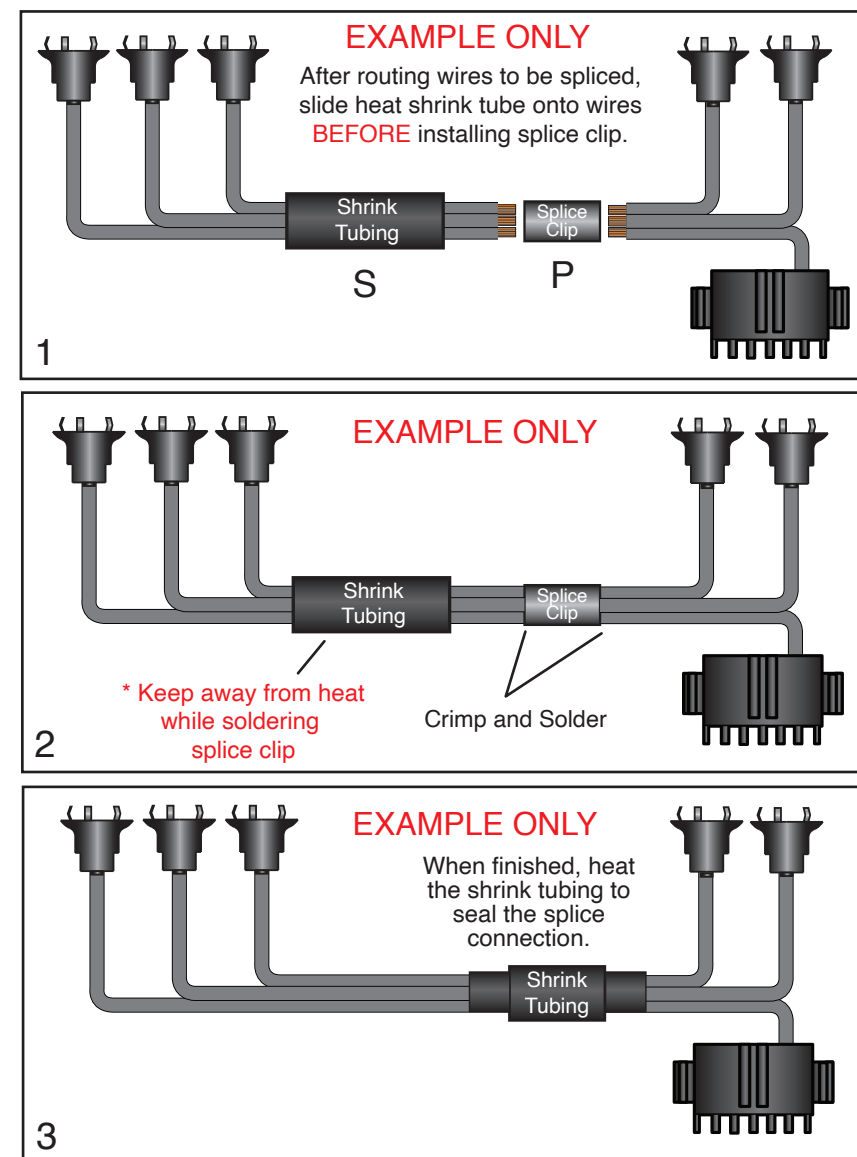

510788 Gauge Cluster harness installation instructions:

USE THIS SHEET TO CONNECT TO AN ORIGINAL **NON-RALLYE** 1971-74 MOPAR B-BODY FACTORY INSTRUMENT CLUSTER

Standard Gauges: All years

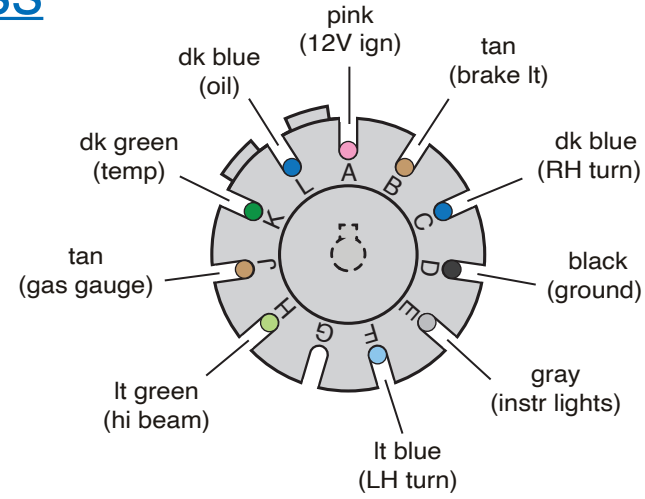

11-way Printed Circuit Board Connector

CONNECTOR A
(wiring end shown)

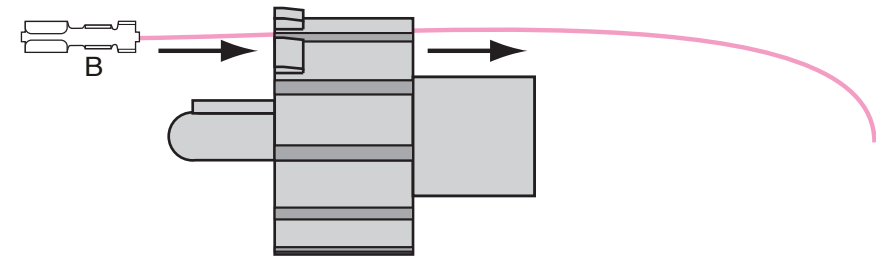

LOADING CONNECTOR 'A':

Cluster connector "A" utilizes "pull-to-seat" terminals. Select a wire, crimp terminal "B" on to it, slip the terminated wire into the wire slot, then pull the terminated wire to seat inside of connector "A" as shown above.

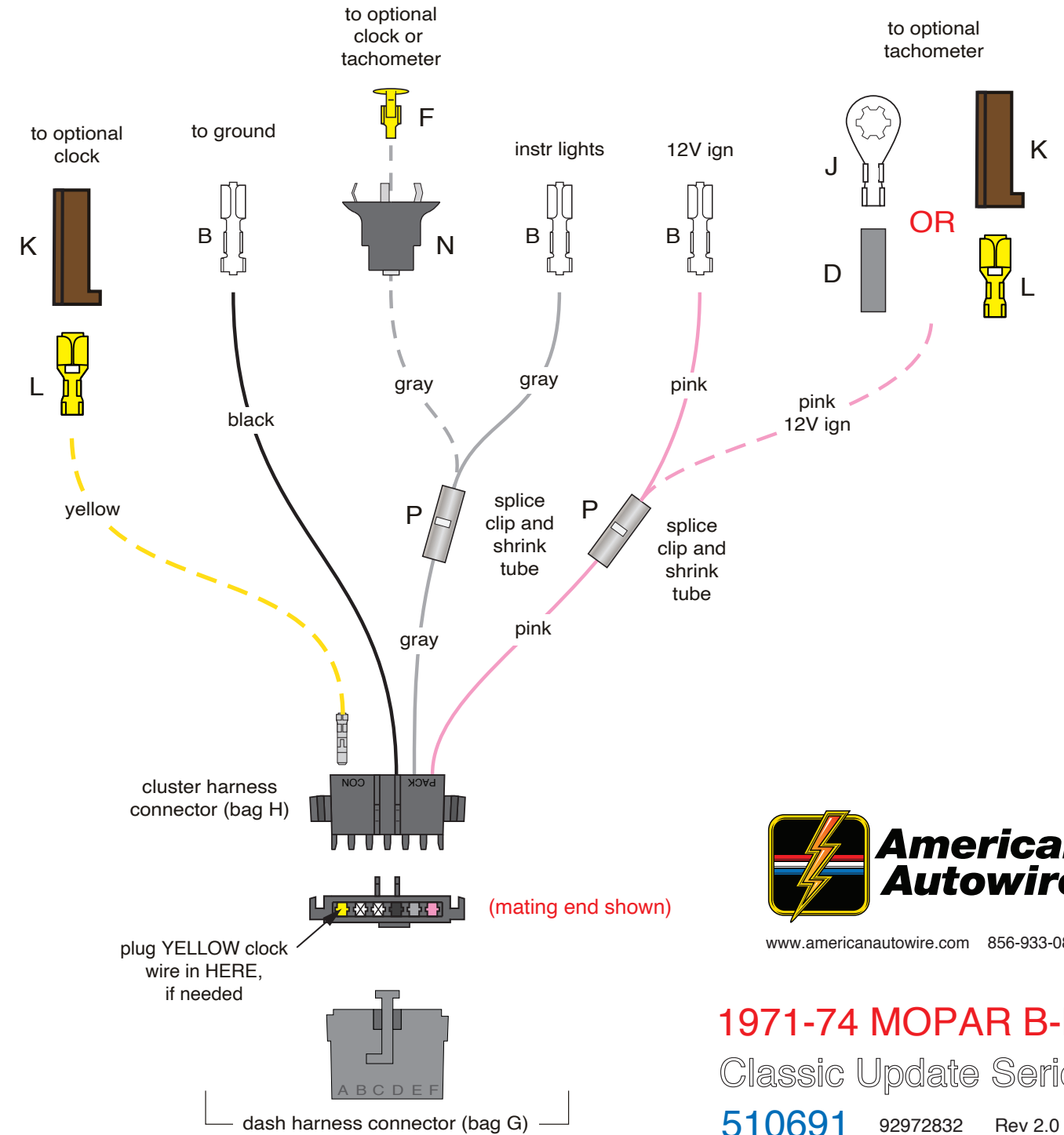
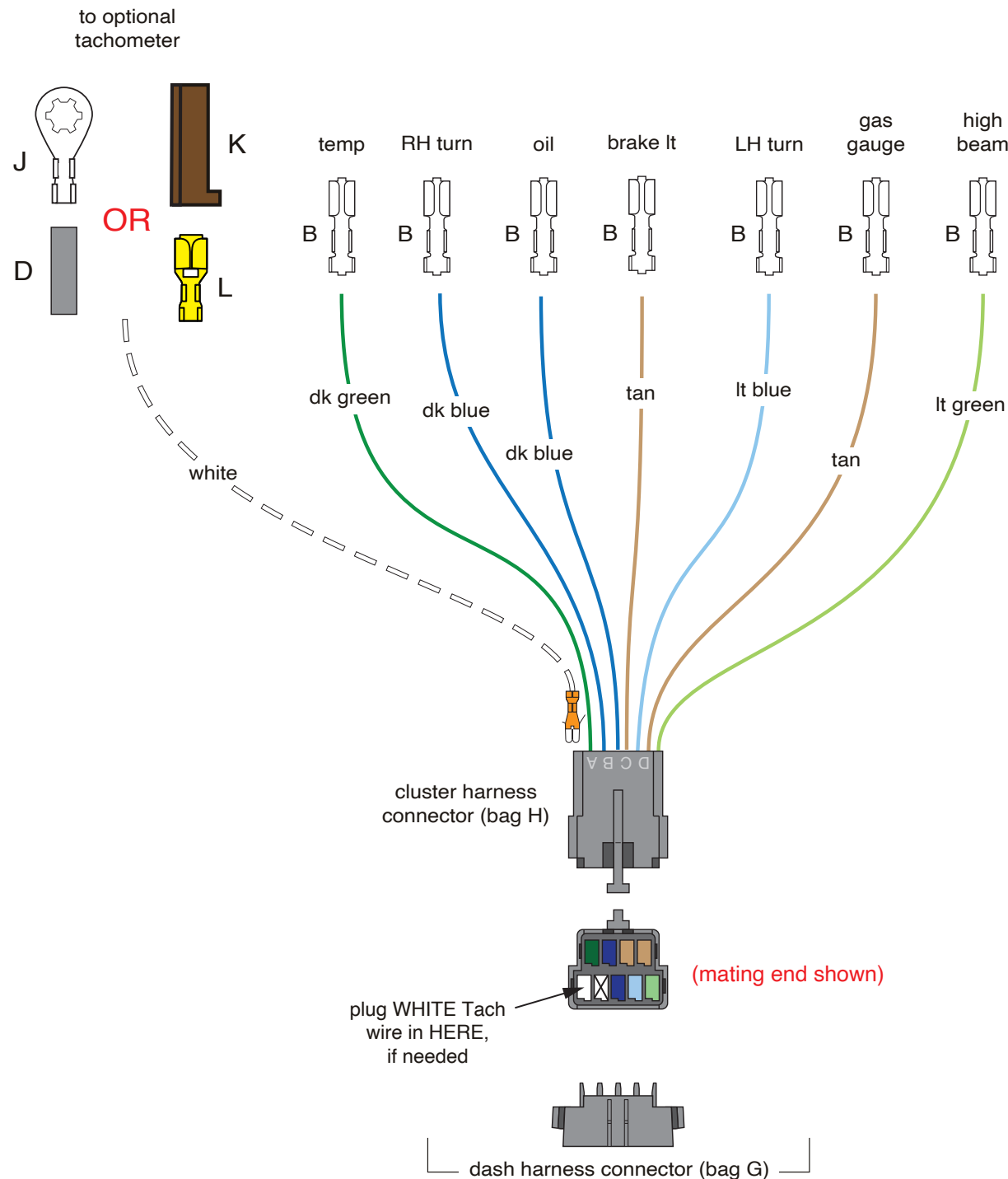

www.americanautowire.com 856-933-0801

1971-74 MOPAR B-Body
Classic Update Series
510691 92972832 Rev 2.0 3/15/2023

510788 Gauge Cluster harness installation instructions:

Non-Rallye (standard) Cluster

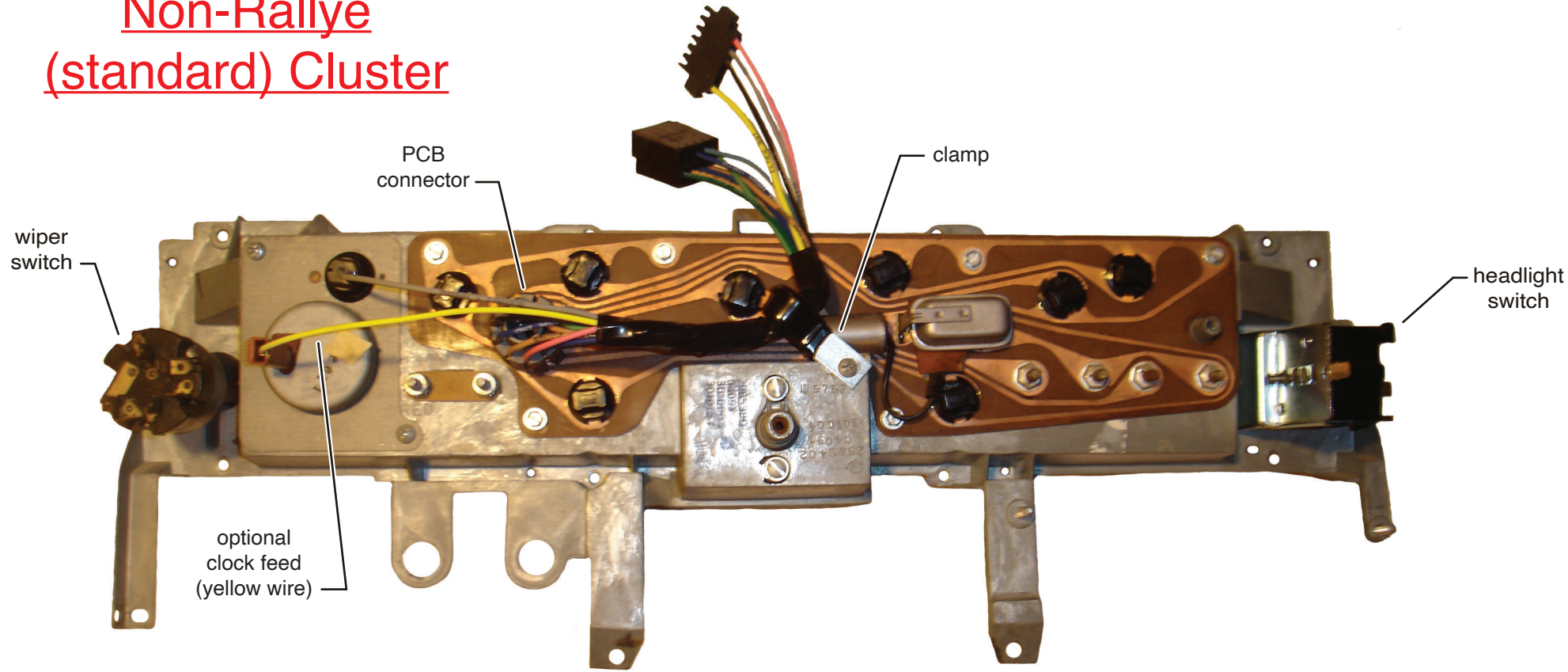

Rallye Cluster

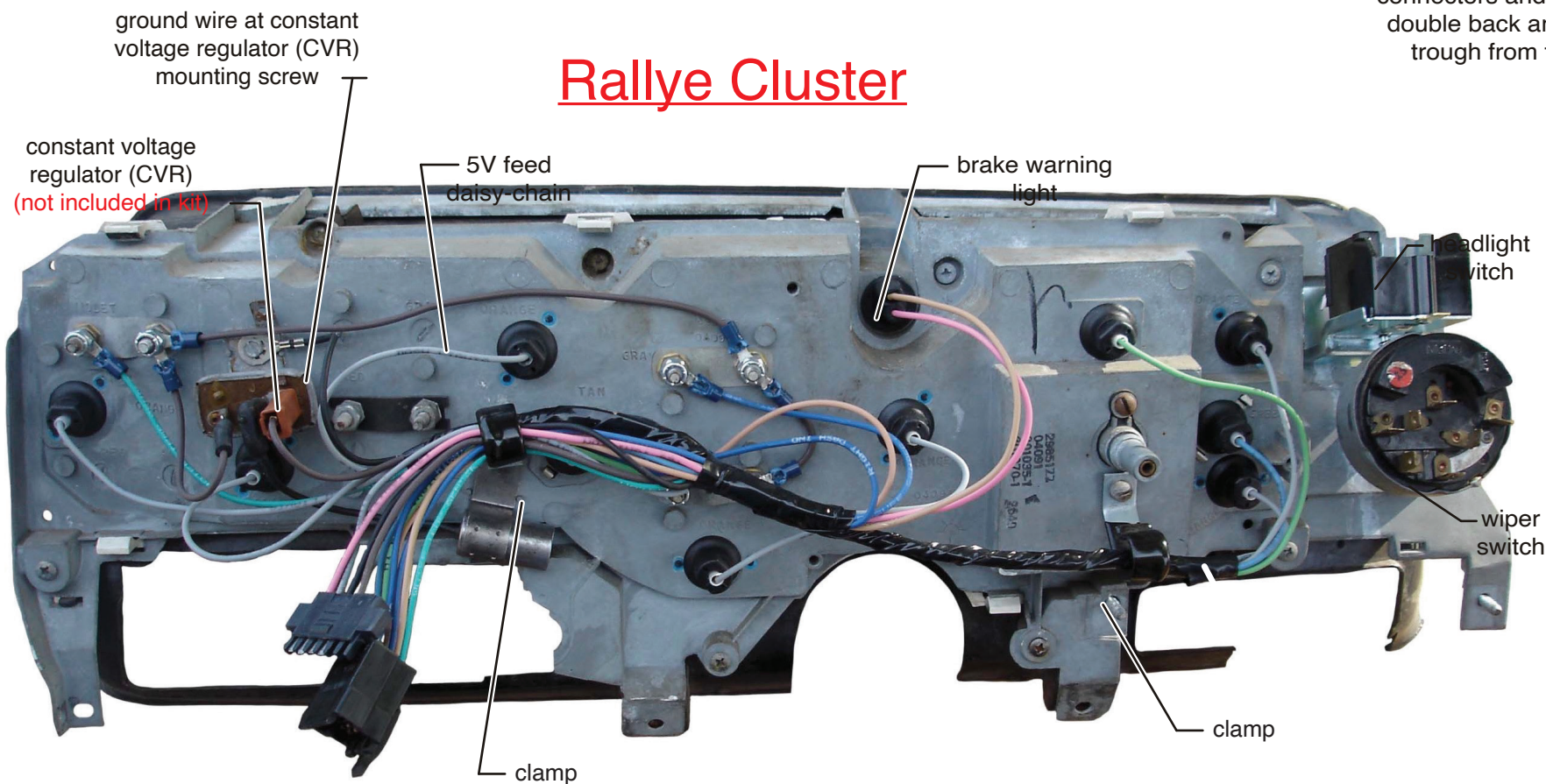

wiring harness "trough"
(viewed from rear
of dashboard;
above cluster)

the Non-Rallye (standard) Cluster wiper switch connectors and wiring, will double back and exit the trough from this end

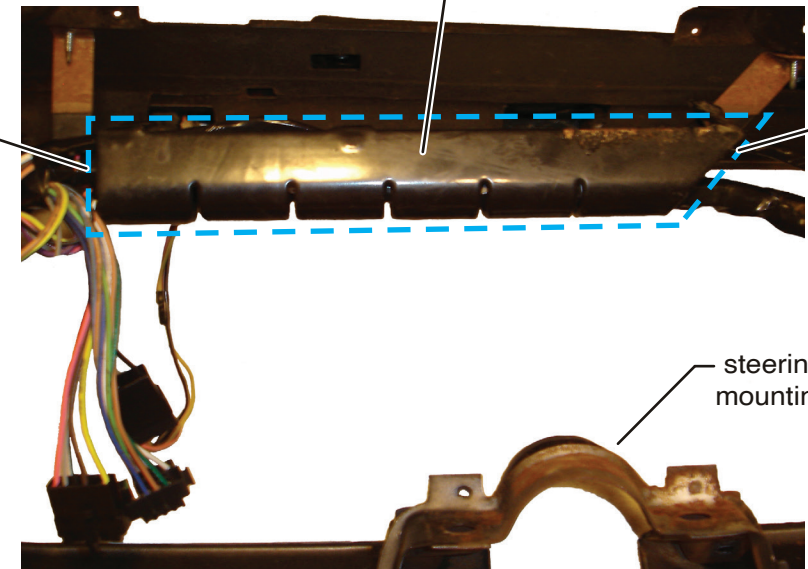

www.americanautowire.com 856-933-0801

1971-74 MOPAR B-Body
Classic Update Series

510691 92972832 Rev 2.0 3/15/2023

510696 Rear Body harness installation instructions:

Below are the supplied misc. terminals, connector bodies and assorted components included in the Rear Body Harness and Loose Piece bags. These will be used to complete your Rear Body Harness connections and are referred by the letters and descriptions below from this point forward.

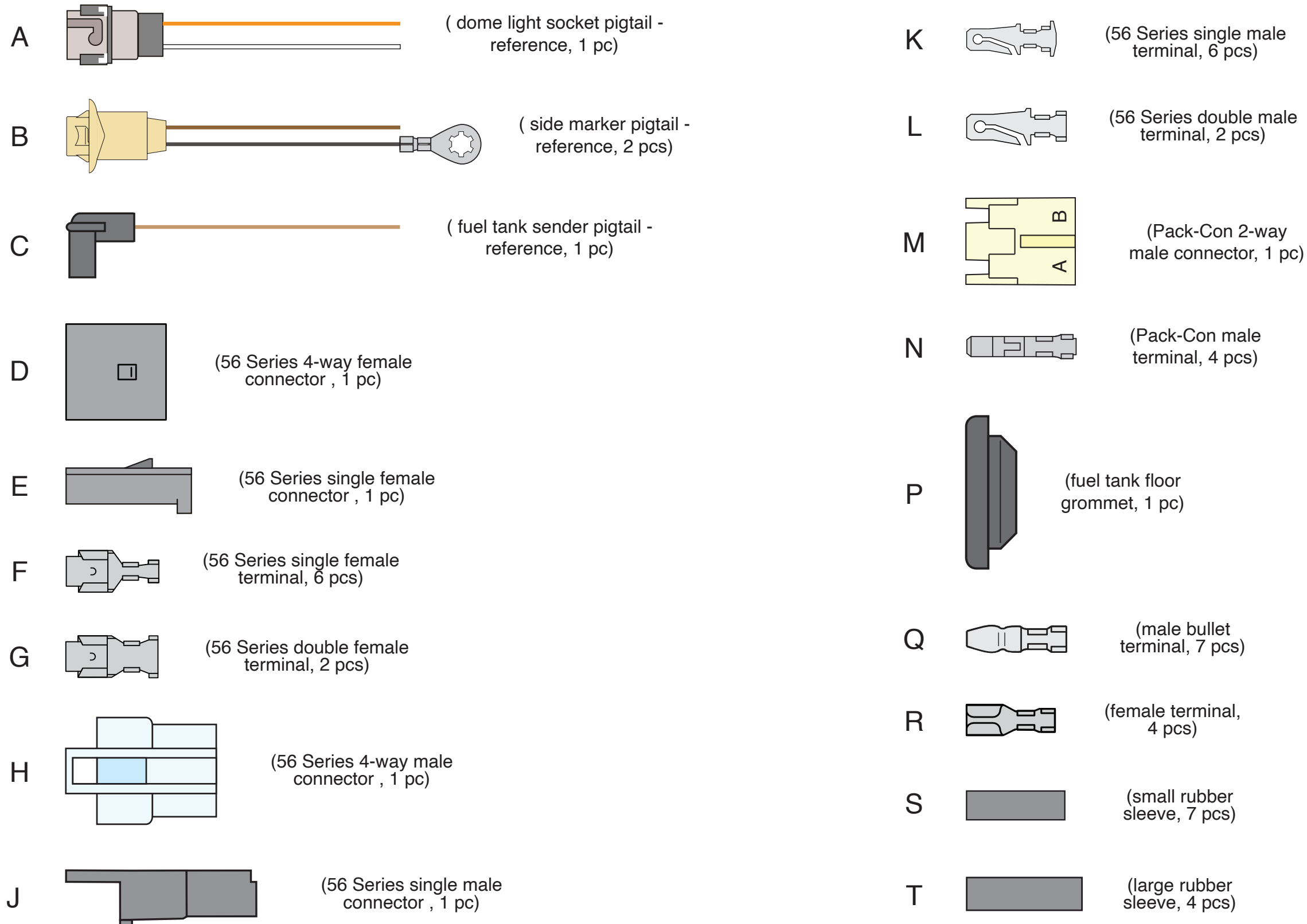

www.americanautowire.com 856-933-0801

1971-74 MOPAR B-Body
Classic Update Series

510691 92972832 Rev 2.0 3/15/2023

510696 Rear Body harness installation instructions:



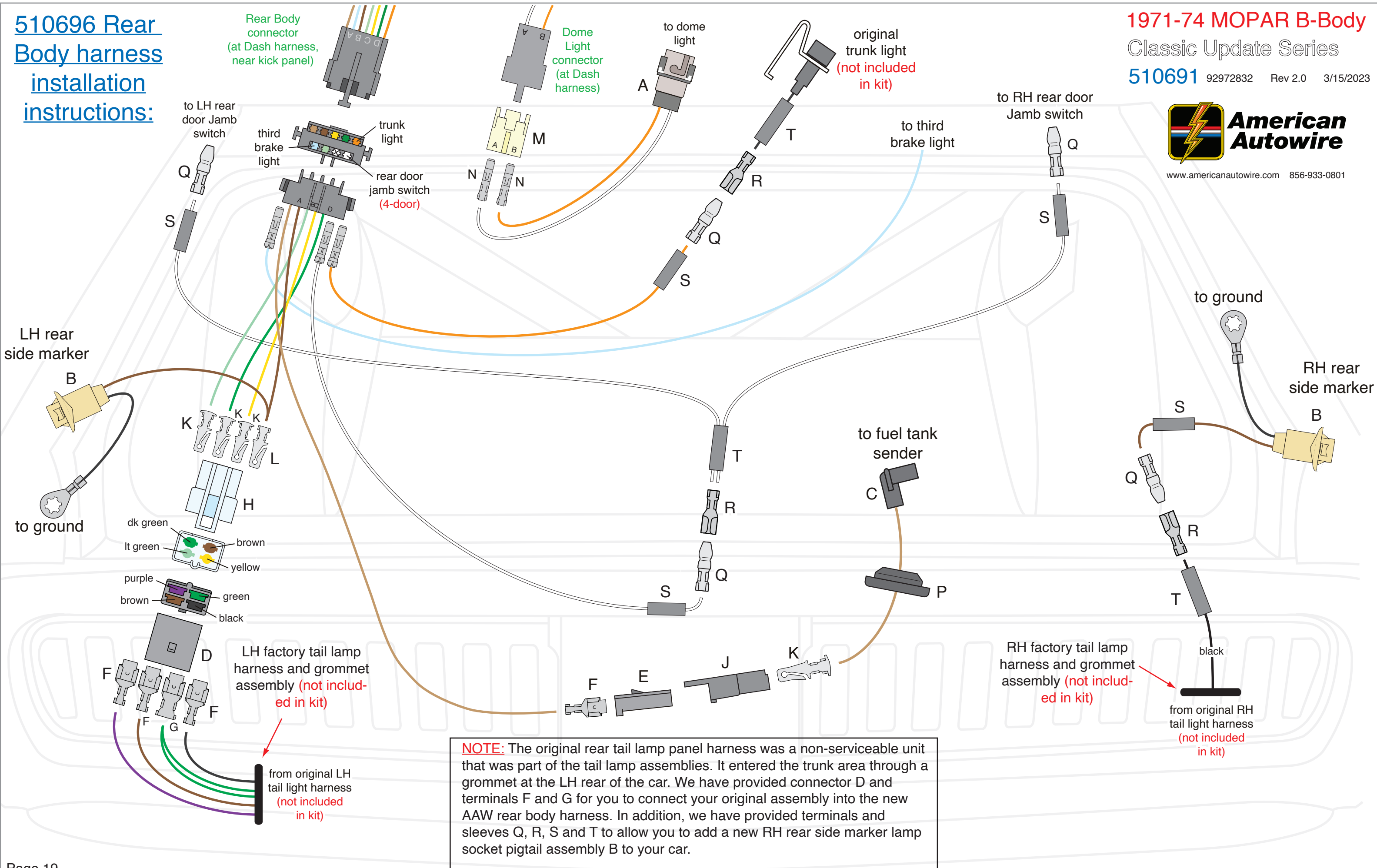







1971-74 MOPAR B-Body
 Classic Update Series
 510691 92972832 Rev 2.0 3/15/2023

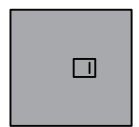
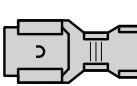

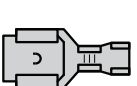
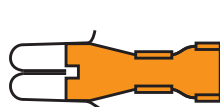
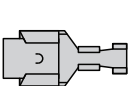
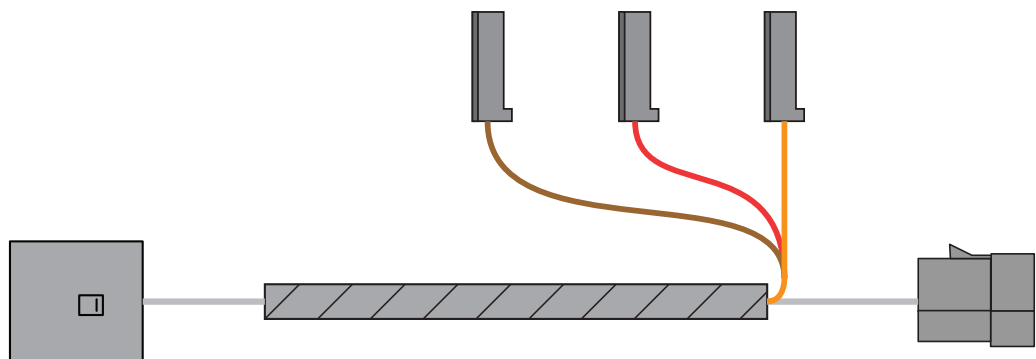
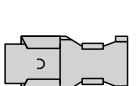
NOTE: The original rear tail lamp panel harness was a non-serviceable unit that was part of the tail lamp assemblies. It entered the trunk area through a grommet at the LH rear of the car. We have provided connector D and terminals F and G for you to connect your original assembly into the new AAW rear body harness. In addition, we have provided terminals and sleeves Q, R, S and T to allow you to add a new RH rear side marker lamp socket pigtail assembly B to your car.

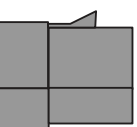
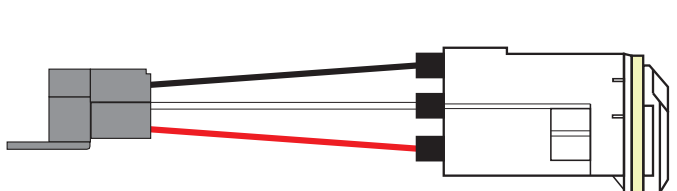
510695 Front Light harness installation instructions:

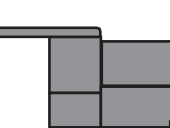
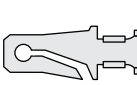
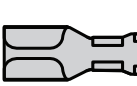
Below are the supplied misc. terminals, connector bodies and assorted components included in the Front Light Harness and Loose Piece bags. These will be used to complete your Front Light Harness connections and are referred by the letters and descriptions below from this point forward.

<p>A </p>	<p>(Headlight pigtail - reference, 2 pcs)</p>	<p>M  (56 Series single female connector, 2 pcs)</p>	<p>N  (56 Series 4-way female connector, 1 pc)</p>
<p>B  (59 Series double female terminal, 8 pcs)</p>		<p>P  (Pack Con 2-way female connector, 2 pcs)</p>	
<p>C  (59 Series single female terminal, 4 pcs)</p>		<p>Q  (Pack Con female terminal, 6 pcs)</p>	
<p>D  (56 Series single female terminal, 9 pcs)</p>		<p>R  (2-speed wiper motor jumper harness - reference, 1 pc)</p>	
<p>E  (56 Series double female terminal, 10 pcs)</p>		<p>S  (side marker light extensions - reference, 2 pcs)</p>	
<p>F  (56 Series 3-way female connector, 2 pcs)</p>		<p>T  (73-74 Plymouth 2-dr Park/Turn socket & pigtail - reference, 2 pcs)</p>	
<p>G  (59 Series 2-way female connector, 2 pcs)</p>		<p>U  (electric fan wire - reference, 1 pc)</p>	
<p>H  (56 Series 3-way male connector, 2 pcs)</p>			
<p>J  (56 Series single male terminal, 9 pcs)</p>			
<p>K  (single female terminal, 4 pcs)</p>			
<p>L  (rubber sleeve, 4 pcs)</p>			



www.americanautowire.com 856-933-0801

1971-74 MOPAR B-Body
 Classic Update Series
510691 92972832 Rev 2.0 3/15/2023

510695 Front Light harness installation instructions:

1971-74 MOPAR B-Body
 Classic Update Series
 510691 92972832 Rev 2.0 3/15/2023

1971-72: All
 1973-74: Dodge

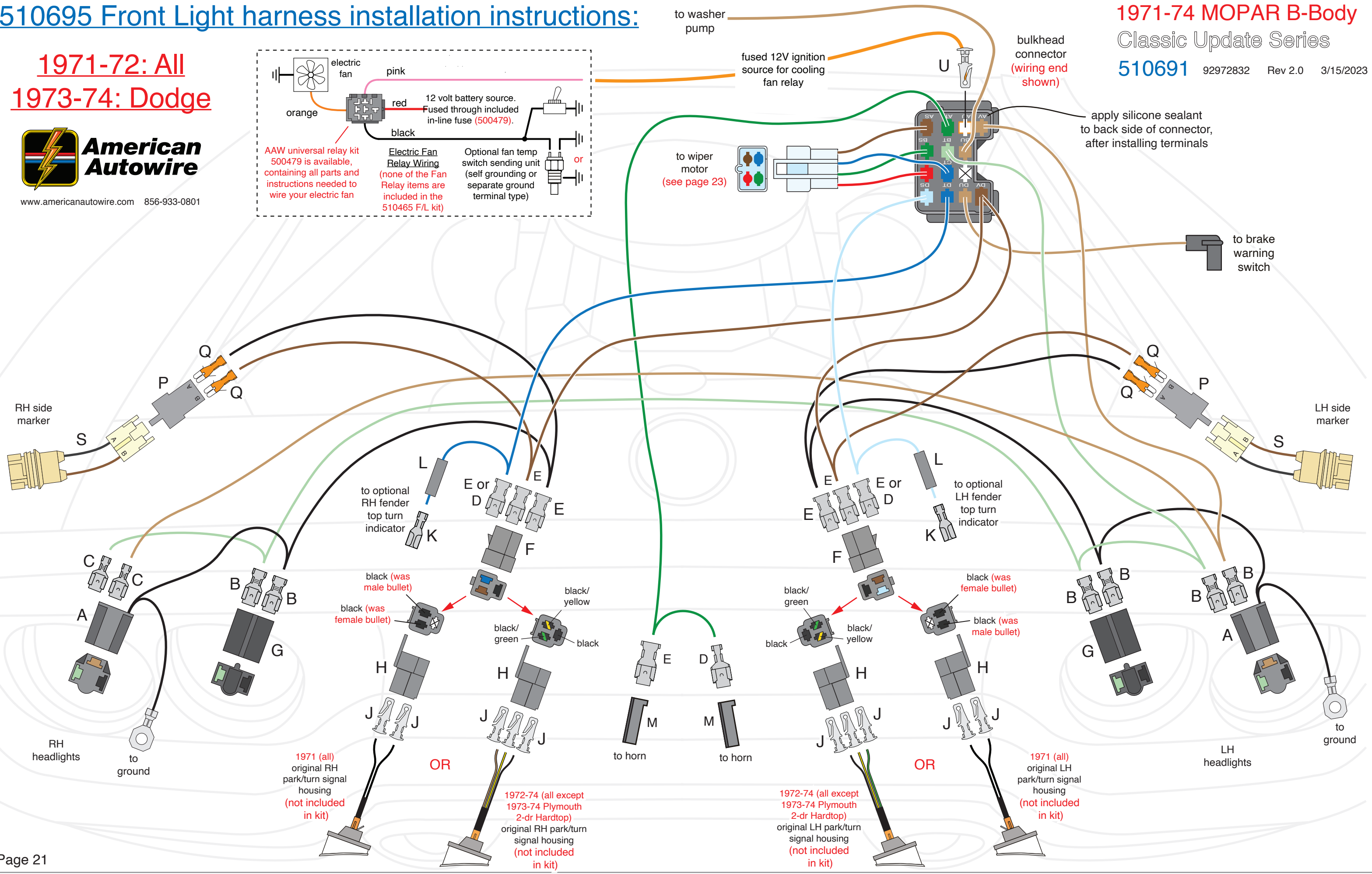
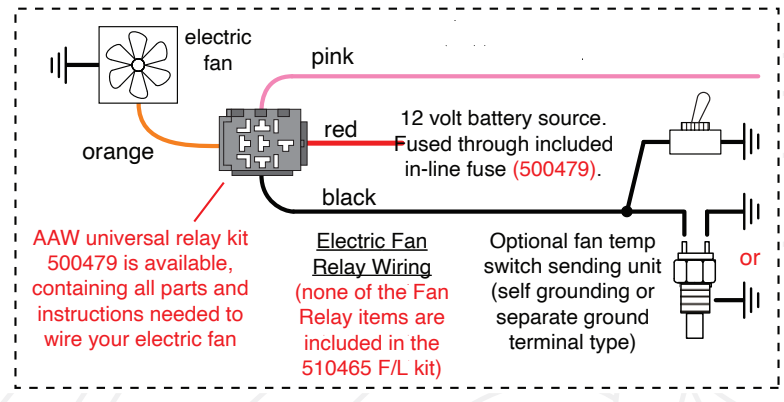

510695 Front Light harness installation instructions:

1973-74: Plymouth 2-Door Hardtop



www.americanautowire.com 856-933-0801

1971-74 MOPAR B-Body
Classic Update Series
510691 92972832 Rev 2.0 3/15/2023

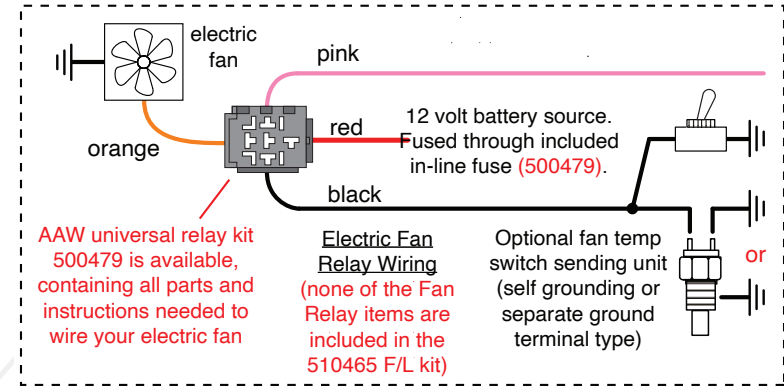

AAW universal relay kit 500479 is available, containing all parts and instructions needed to wire your electric fan

Electric Fan Relay Wiring (none of the Fan Relay items are included in the 510465 F/L kit)

Optional fan temp switch sending unit (self grounding or separate ground terminal type)

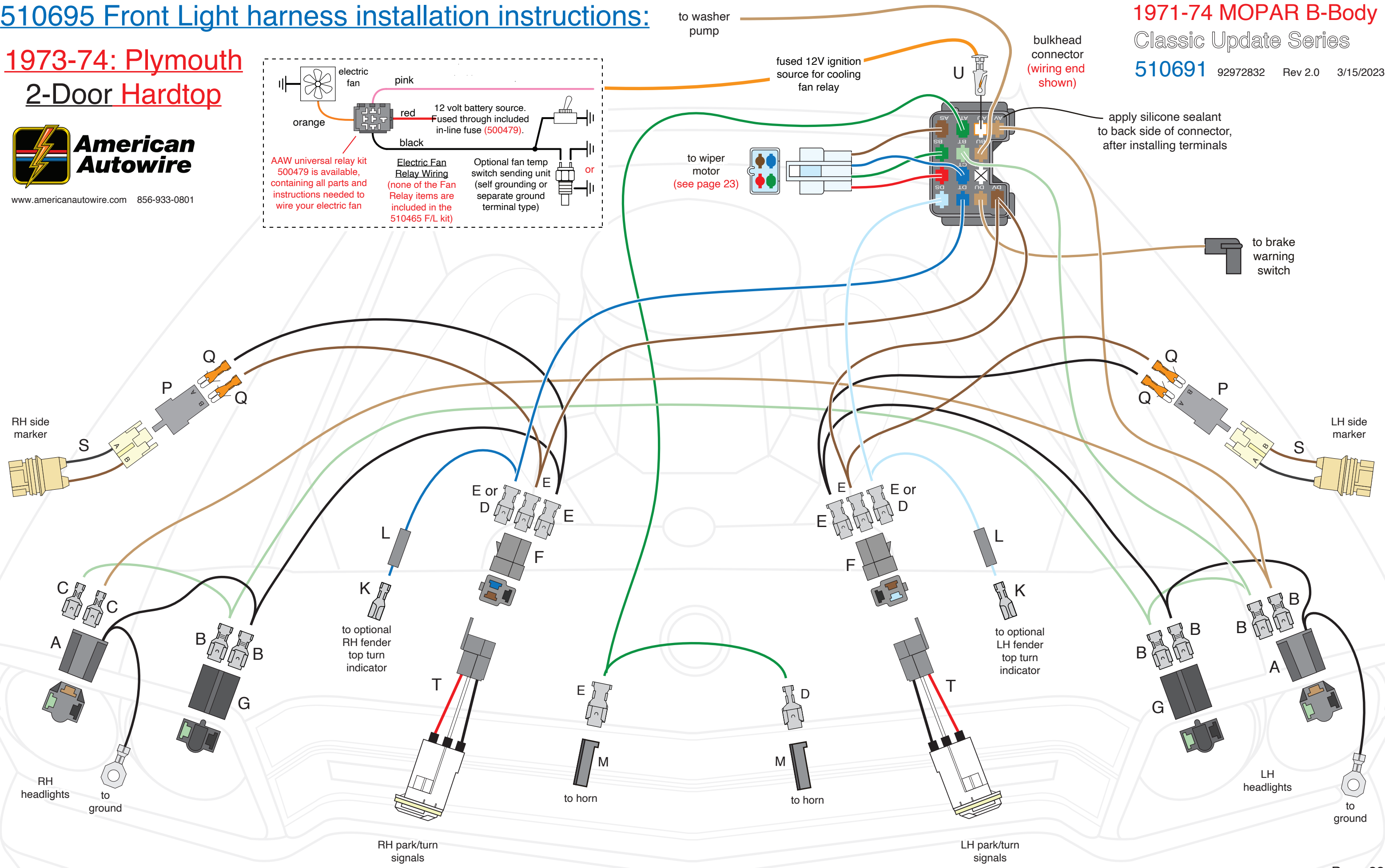

bulkhead connector (wiring end shown)

apply silicone sealant to back side of connector, after installing terminals

510695 Front Light harness installation instructions:

1971 2-speed wiper motor wiring:

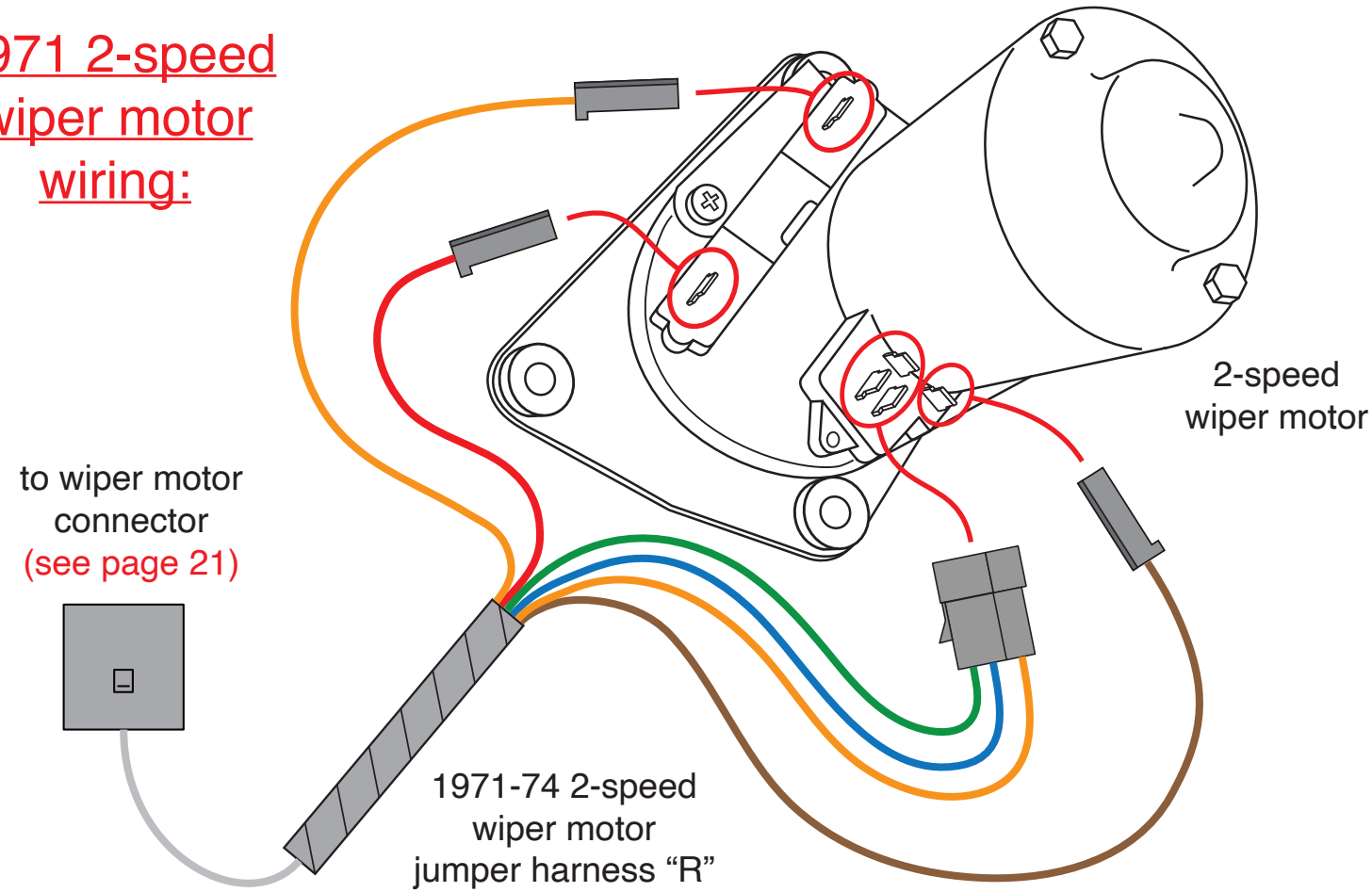

1972-74 2-speed wiper motor wiring:

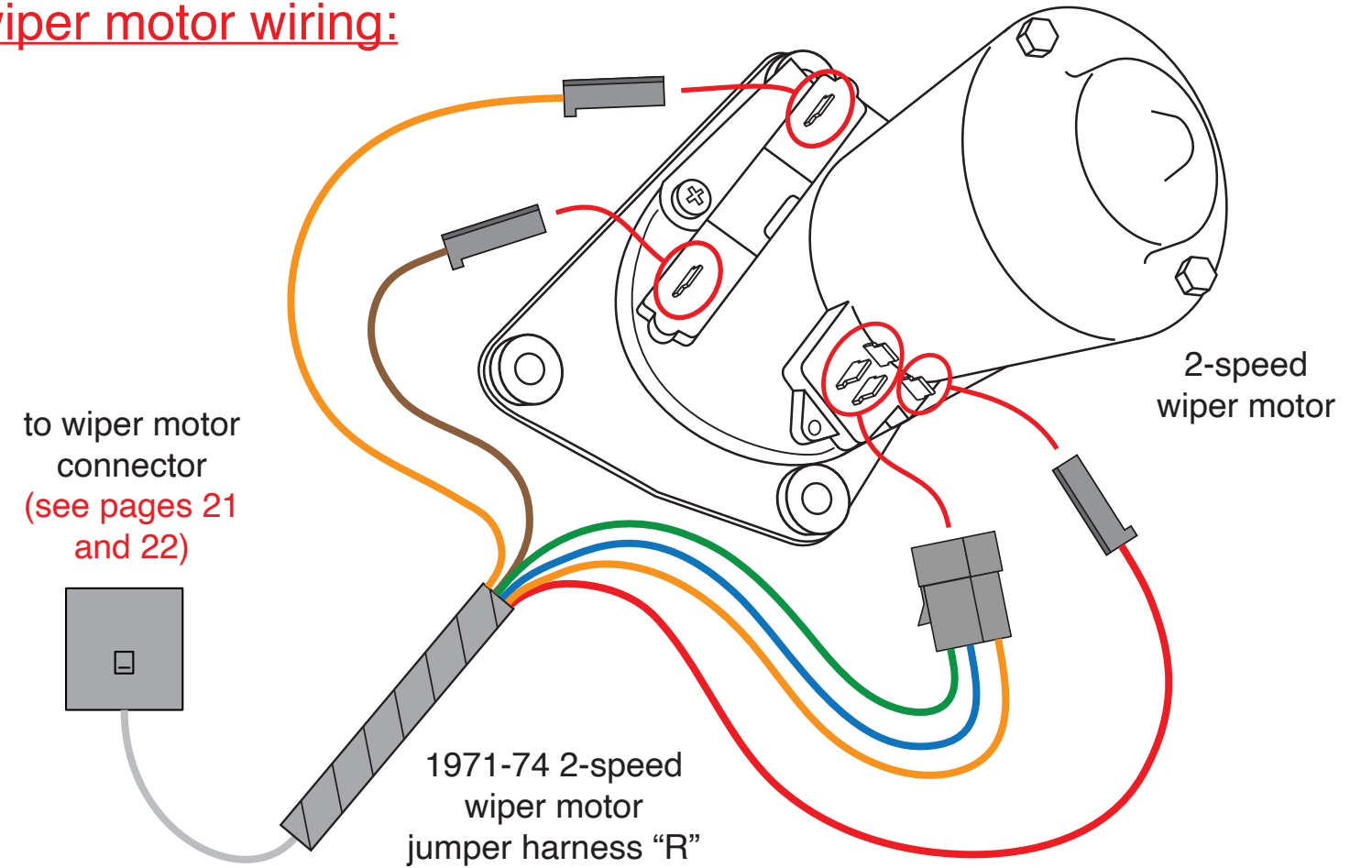

1971 variable-speed and 1972-74 3-speed wiper motor wiring:

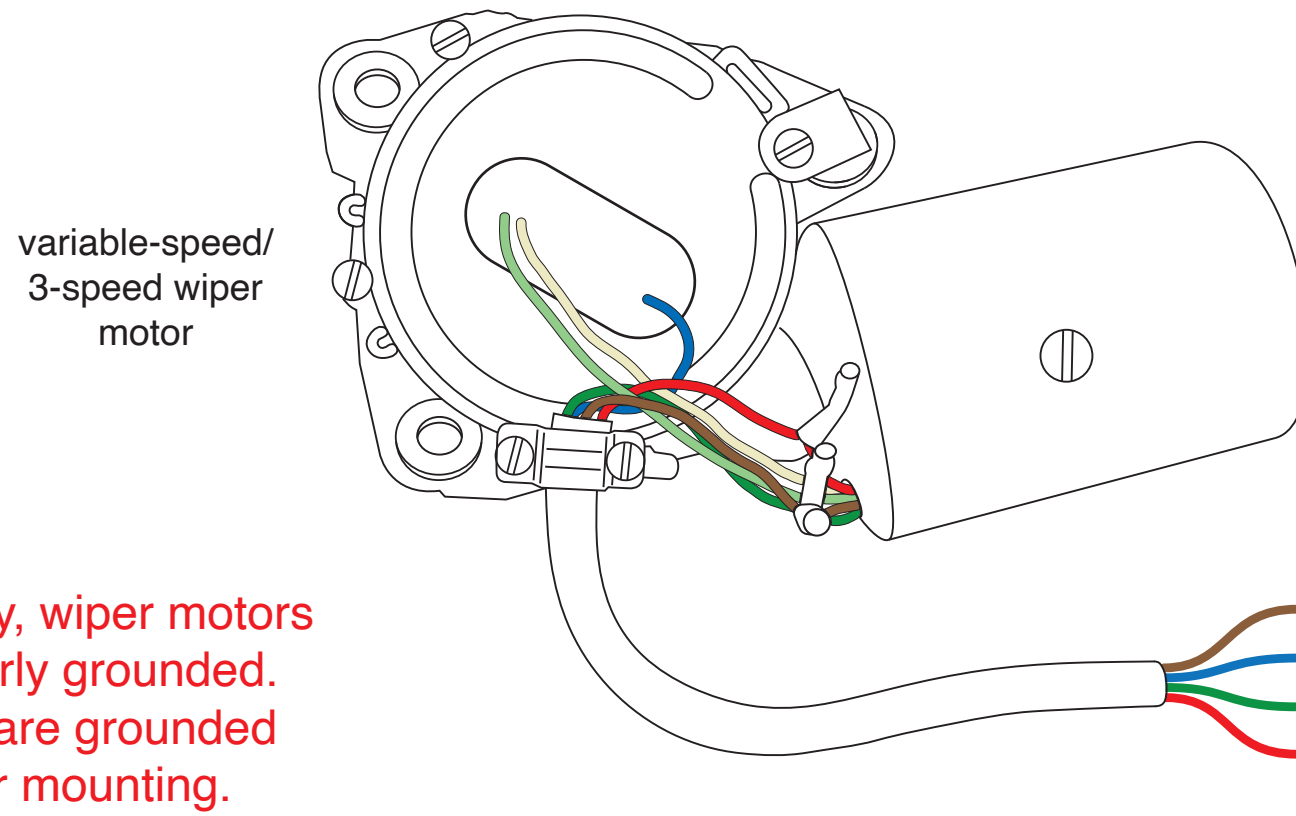

NOTE: Mating connector N and terminals D, to complete your wiper motor connection, are located in the loose piece kit for this harness (92971829).

NOTE: To work correctly, wiper motors must be properly grounded. Wiper motors are grounded through their mounting.













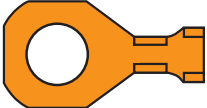
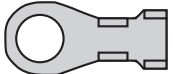

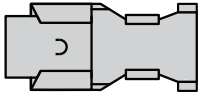

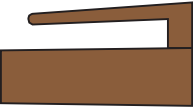
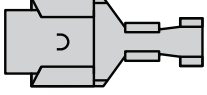

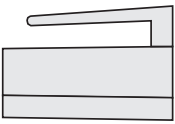
www.americanautowire.com 856-933-0801

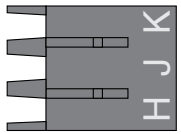
1971-74 MOPAR B-Body Classic Update Series

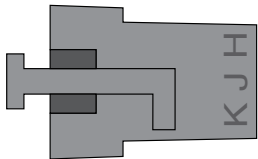
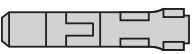
510691 92972832 Rev 2.0 3/15/2023

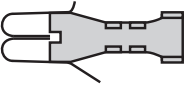
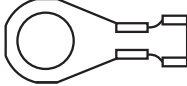
510786 Engine harness installation instructions:

Below are the supplied misc. terminals, connector bodies and assorted components included in the Engine Harness and Loose Piece bags. These will be used to complete your Engine Harness connections and are referred by the letters and descriptions below from this point forward.

- | | | |
|--|--|--|
| <p>A  (ring terminal, 4 pcs)</p> | <p>L  (ring terminal, 3 pcs)</p> | <p>U  (electric choke pigtail - reference, 1 pc)</p> |
| <p>B  (56 Series double female terminal, 6 pcs)</p> | <p>M  (ring terminal, 4 pcs)</p> | <p>V  (56 Series single female connector, 1 pc)</p> |
| <p>C  (56 Series single female terminal, 9 pcs)</p> | <p>N  (small sleeve, 7 pcs)</p> | <p>W  (56 Series single female connector, 1 pc)</p> |
| <p>D  (56 Series single female connector, 8 pcs)</p> | <p>P  (Pack Con 3-way male connector, 1 pc)</p> | <p>X  (back-up lamp feed - reference, 1 pc)</p> |
| <p>E  (large sleeve, 6 pcs)</p> | <p>Q  (Pack Con 3-way female connector, 1 pc)</p> | <p>Y  (Pack Con male terminal, 4 pcs)</p> |
| <p>G  (56 Series single female connector, 2 pcs)</p> | <p>R  (clutch interlock ground pigtail - reference, 1 pc)</p> | <p>Z  (Pack Con female terminal, 4 pcs)</p> |
| <p>H  (ring terminal, 3 pcs)</p> | <p>S  (starter solenoid feed pigtail - reference, 1 pc)</p> | |
| <p>J  (56 Series single male terminal, 2 pcs)</p> | <p>T  (starter to starter relay pigtail, 1 pc)</p> | |

510786 Engine harness installation instructions:

1971-74 MOPAR B-Body

Classic Update Series

510691 92972832 Rev 2.0 3/15/2023



www.americanautowire.com 856-933-0801

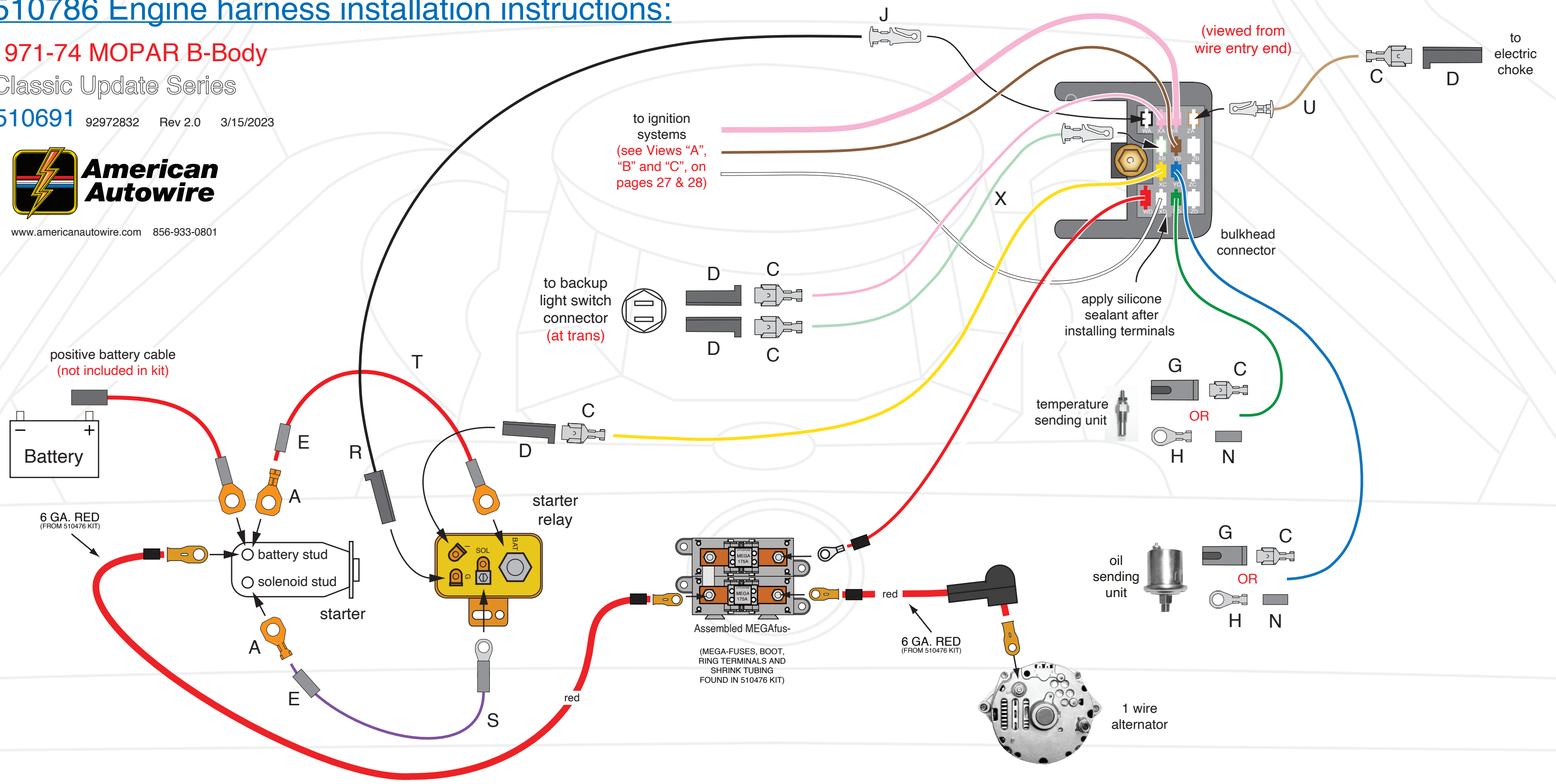

ALL MANUAL
TRANS

510786 Engine harness installation instructions:

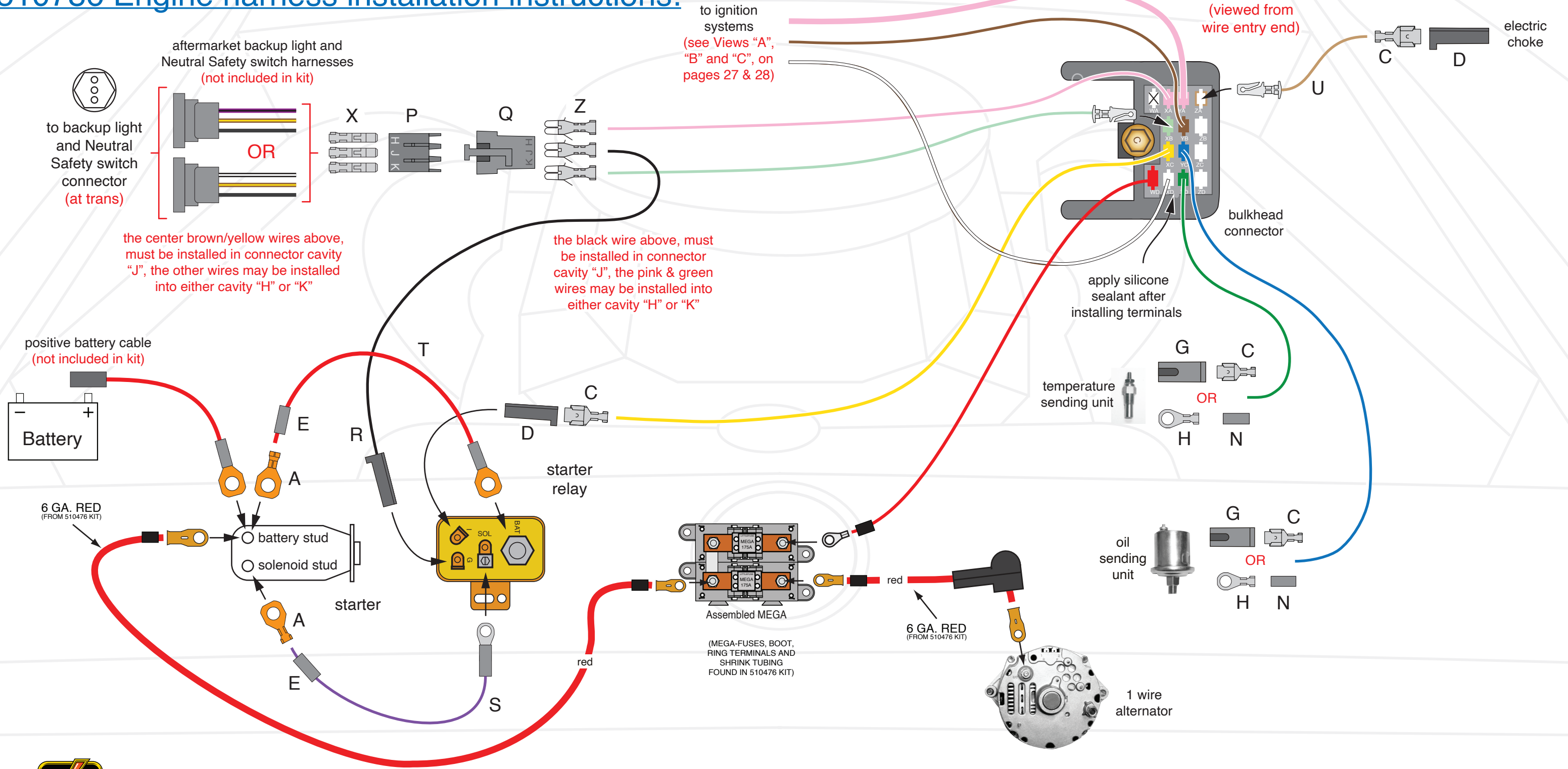

ALL AUTOMATIC TRANS

1971-74 MOPAR B-Body
Classic Update Series

510786 Engine harness installation instructions:

Ignition systems wiring:

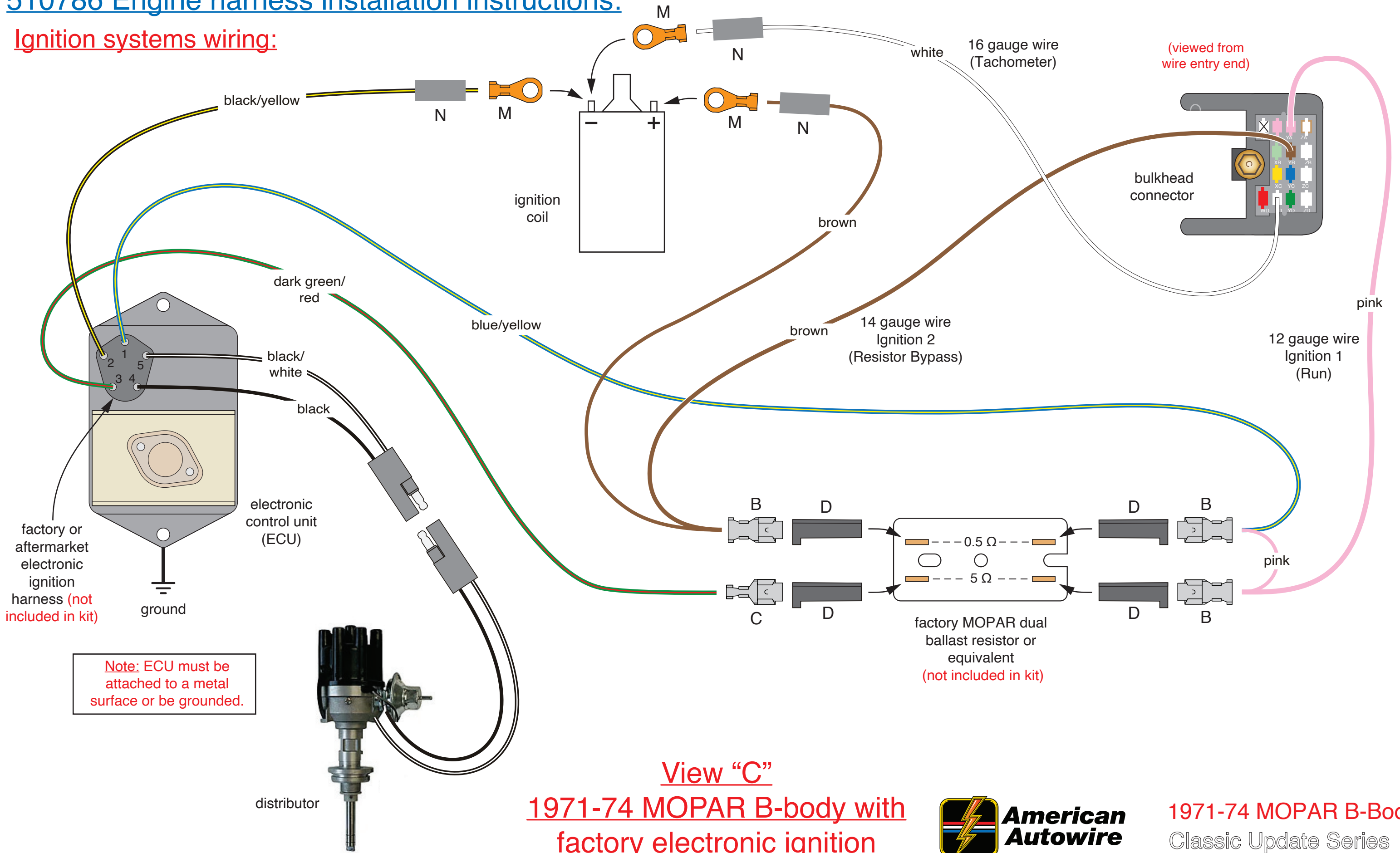

View "C" 1971-74 MOPAR B-body with factory electronic ignition



www.americanautowire.com 856-933-0801

1971-74 MOPAR B-Body
Classic Update Series

510691 92972832 Rev 2.0 3/15/2023

510786 Engine harness installation instructions:

Ignition system wiring:

View "A" with points

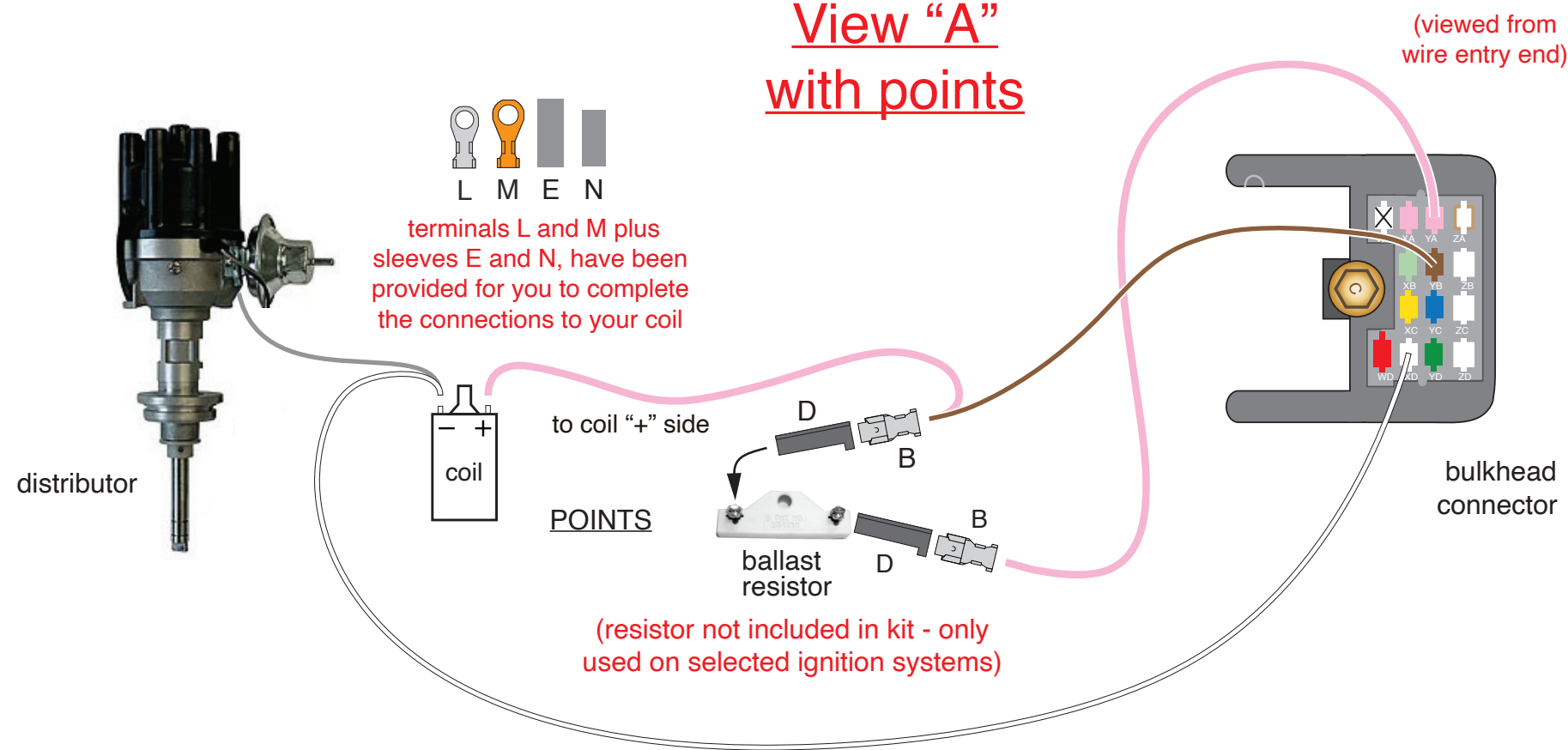

View "B" with HEI distributor

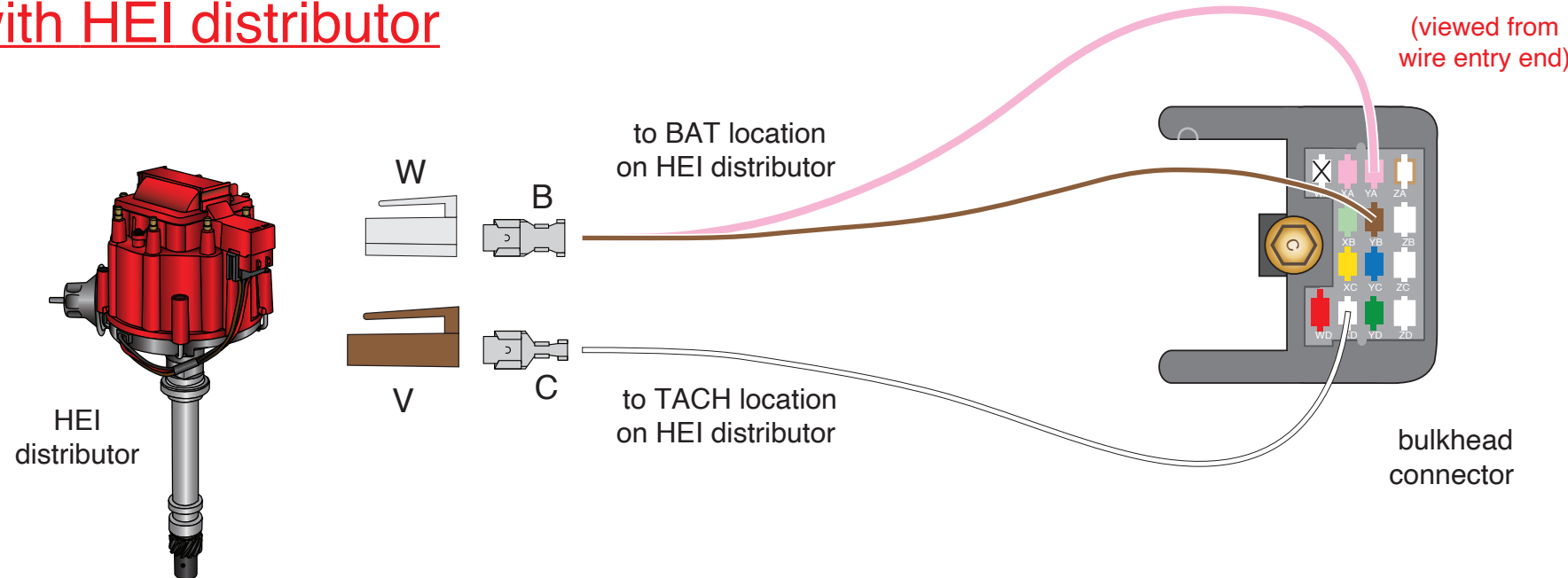

Ignition system wiring: OTHER IGNITION TYPES

FOR OTHER TYPES OF IGNITION SYSTEMS AND/OR EFI APPLICATIONS:

The Pink and Brown ignition wires may be connected together and used as a keyed 12(+) power feed to your ignition box or EFI computer control harness or computer.

Please note: **These wires are not fused.** Please consult the instructions for your ignition system or EFI harness to confirm if an in-line fuse is required.

Finally: The pink and brown wires **must be used together** in order for their to be power when the key is in the run and crank position.

FINAL STEPS:

RECONNECT YOUR BATTERY:

When you have completed the installation and are ready to reconnect the battery, make sure that the following electrical system grounds are in place:

- A. Battery is grounded to the ENGINE BLOCK.
- B. Battery is grounded to the frame.
- C. Engine block is grounded to the frame.
- D. Body is grounded to the frame.

STEP 4: CHECK ALL ELECTRICAL FUNCTIONS:

Any non-functioning items should be checked for proper installation. Any problems with your wiring and electrical circuit functions, should be addressed to American Autowire Systems, Inc. as soon as possible, to avoid any warranty problems.

If you have any questions concerning this or any of our products, please feel free to call us at 1-856-933-0801.



www.americanautowire.com 856-933-0801

1971-74 MOPAR B-Body

Classic Update Series

510691 92972832 Rev 2.0 3/15/2023

THIS PAGE HAS INTENTIONALLY
BEEN LEFT BLANK



www.americanautowire.com 856-933-0801

1971-74 Mopar B-Body
Classic Update Series
510691 92972832 Rev 0.0 1/7/2020

A  (1)
 (144.0" 6 Gauge charge wire)

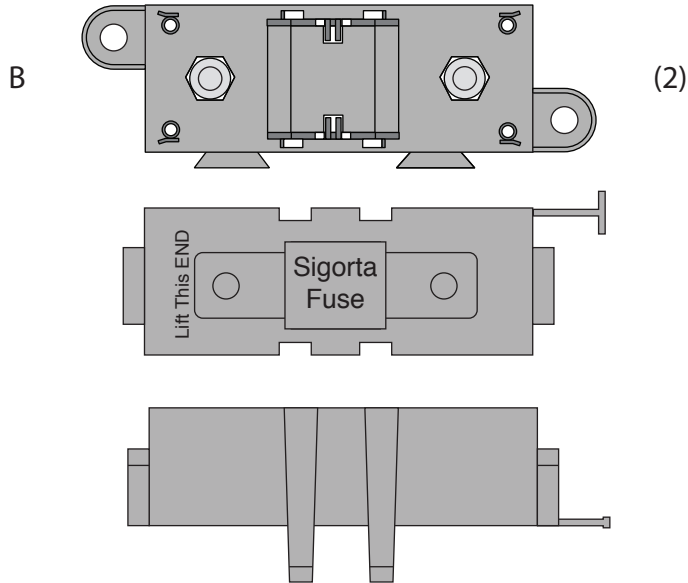

1. On this page, you will find the wire, fuse bodies, fuses, boot, ring terminals, and shrink tubing (items A through K) that are necessary to connect your alternator and main power feed for your new AAW wiring kit. Please be sure that all of the necessary components are present before starting this portion of your installation. If anything is missing, stop what you are doing and contact AAW at the number listed below right away.

2. On page 2, you will find directions for building the 2 Megafuse assemblies (items B,C and D) into one unit.

3. On page 3, you will find an overall concept of how to connect the Megafuse assemblies to your starter solenoid, alternator and main power feed of your new wiring system.

4. On page 4, you will find tips on building your charging circuit wires and assembling them and the main panel power feed wire to the Megafuse assemblies.

(Megafuse body, cover and two M8 x 1.25 nuts / lock washers)

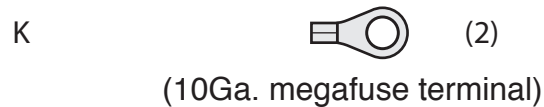
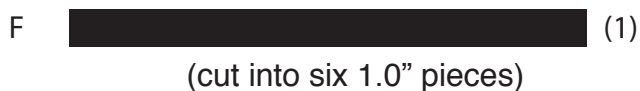
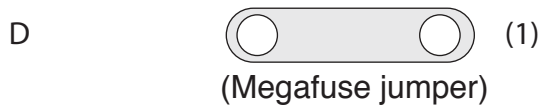
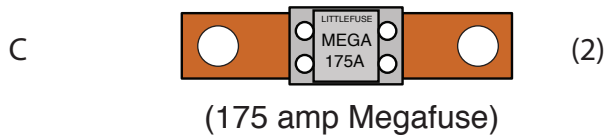

www.americanautowire.com 856-933-0801

PART #

510476

Z

DESCRIPTION:

Alternator and Main Power
 Connection Kit
 Various Applications

92972153 instruction sheet rev 0.1 6/24/2019

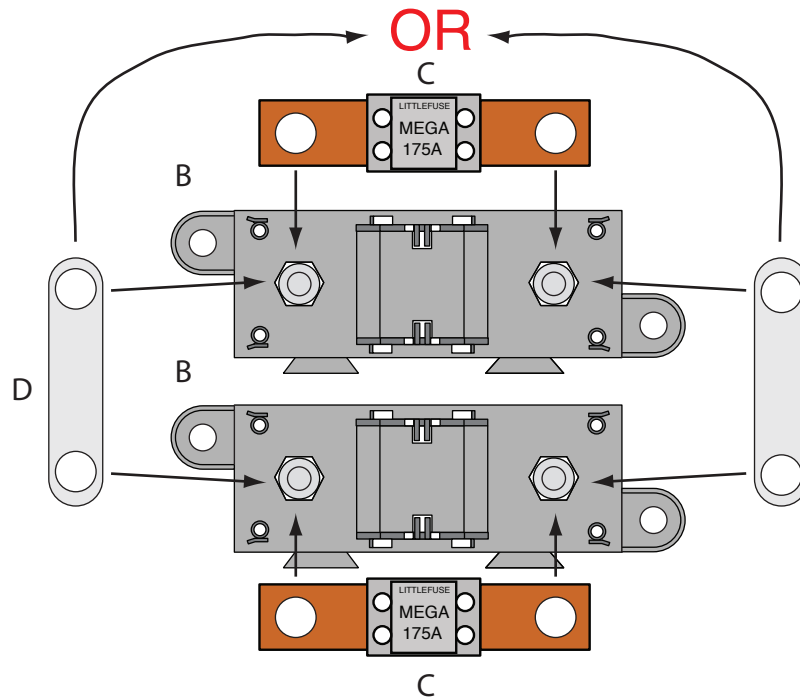

Assembling the (2) Megafuse assemblies

NOTE: Find a suitable place, as close to the battery power source as possible, under the hood of your vehicle to mount the completed Megafuse assemblies. Keep in mind that you have 12 feet of 6Ga. charging wire, and that the main power feed coming from your panel or bulkhead connection must also be able to reach the assembly.

1. Take the two Megafuse bodies and covers (items B) and snap them together. Remove the 4 nuts and lock washers from the studs on the fuse body assemblies.
2. Install the Megafuse jumper (item D above) over two of the studs on the Megafuse bodies. It is very important that the jumper **MUST BE** assembled on the side that is going to connect to your main power connection (starter solenoid or battery feed).
3. Notch top cover to clear jumper D as shown at right.
4. Snap one 175amp fuse (items C) onto the studs of each of the two Megafuse bodies (items B), over the jumper, then loosely re-attach the 4 nuts and lock washers back onto the assembled Megafuses. The fuse assemblies are ready to install into your vehicle.

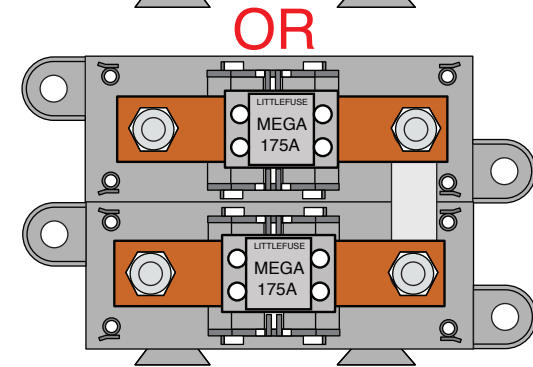
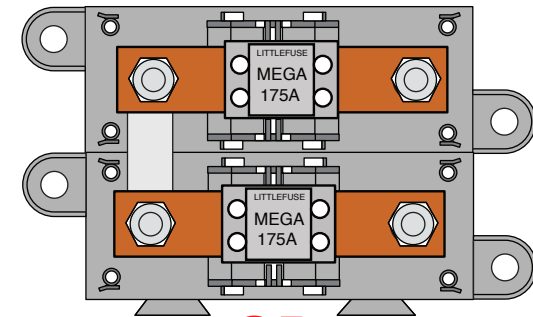

Assembled Megafuses

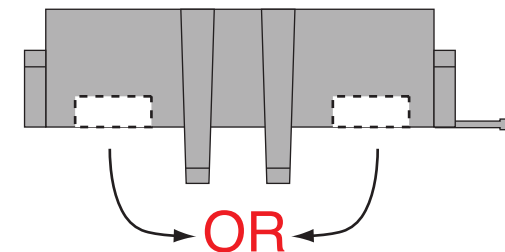

Notched Cover

PART #

510476

Z

DESCRIPTION:

Alternator and Main Power
Connection Kit
Various Applications

92972153 instruction sheet rev 0.1 6/24/2019

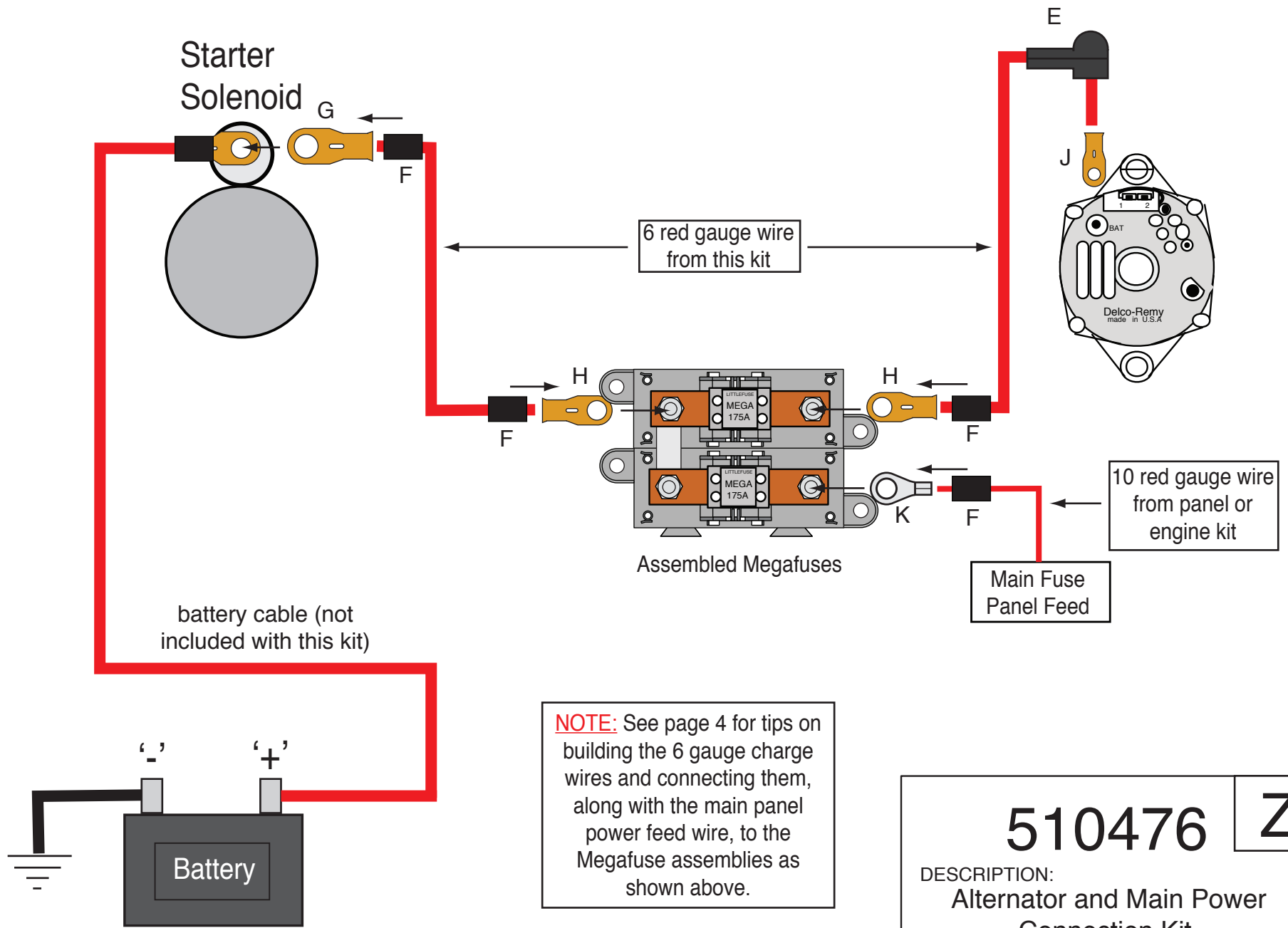

NOTE: See page 4 for tips on building the 6 gauge charge wires and connecting them, along with the main panel power feed wire, to the Megafuse assemblies as shown above.

<h1>510476</h1>	Z
<p>DESCRIPTION: Alternator and Main Power Connection Kit Various Applications</p>	
<p>92972153 instruction sheet rev 0.1 6/24/2019</p>	

Building the 6Ga. charge wires and connecting them and the main panel power feed wire to the Megafuse assemblies:

NOTE: Make sure that your battery is disconnected! You will need to install the preassembled Megafuses from page 2 in your vehicle to start this part of the installation.

1. Pre-cut item F shrink tubing into (6) 1.00" - 1.25" pieces.
2. Take the 12-foot piece of 6Ga. red wire from this kit and route it from your starter (or other battery feed) over to the area where you have mounted your Megafuse and cut it to length. Strip the insulation on each end back 1/2". Install 2 pieces of shrink tubing F onto the wire. At the starter end, crimp and solder (1) of terminal G onto the wire. At the Megafuse end, crimp and solder (1) of terminal H onto the wire. Slide the shrink tubing over the terminals and heat it up to shrink it down.
3. Take the remaining portion of the 12-foot piece of 6Ga. red wire from this kit and route it from your alternator over to the area where you have mounted your Megafuse and cut it to length. Strip the insulation on each end back 1/2". Install 1 piece of shrink tubing F onto the wire. At the alternator end, slip on boot E as shown on page 3, then crimp and solder (1) of terminal J onto the wire. At the Megafuse end, crimp and solder (1) of terminal H onto the wire. Slide the shrink tubing over terminal H and heat it up to shrink it down.
4. Take the 10Ga. red main power feed wire from your engine or panel sub-kit and route it over to the area where you have mounted your Megafuse and cut it to length. Strip the insulation back 3/8". Install 1 piece of shrink tubing F onto the wire, then crimp and solder (1) of terminal K onto the wire.
5. Remove the 4 loosely tightened nuts and lock washers from the assembled Megafuses, then using the drawing on page 3 as a guide, install your pre-assembled wires from steps 2-4 above. Re-install the 4 nuts and lock washers onto the assembled Megafuses and tighten them down. This part of your installation is now complete.

510476

Z

DESCRIPTION:

**Alternator and Main Power
Connection Kit
Various Applications**

92972153 instruction sheet rev 0.1 6/24/2019

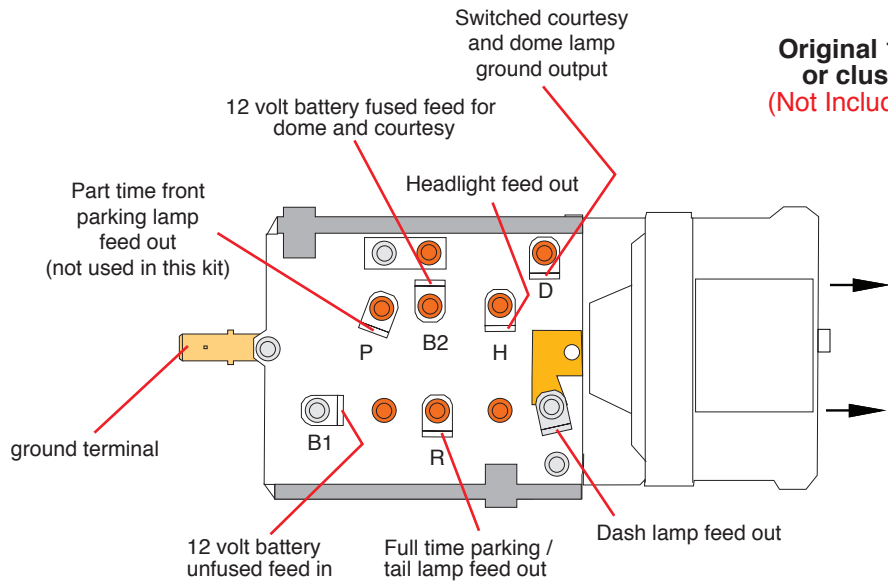

Original 1971-74 dash or cluster housing
(Not Included with this kit)

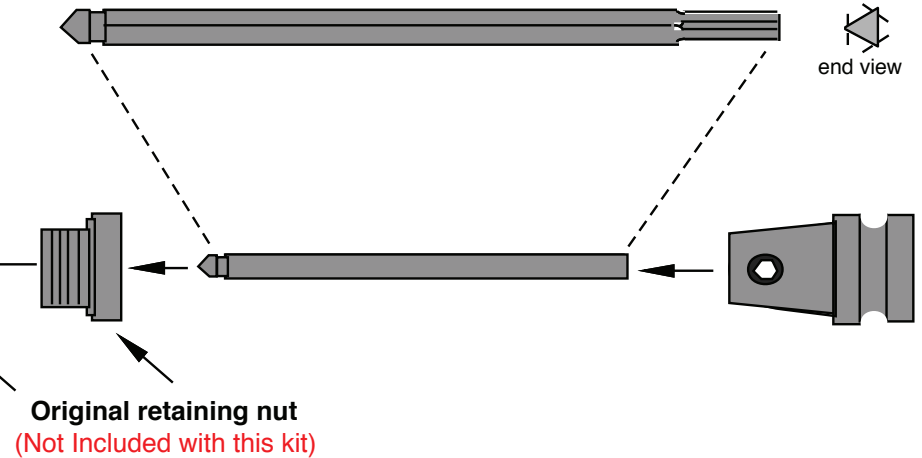

Original retaining nut
(Not Included with this kit)



NOTE: We have provided a new custom length shaft and knob in this kit. Below, we have included instructions on how to assemble it. However, if you would rather use your original knob/shaft assembly, it will work fine in this OE style replacement switch.

1. Install the new switch into your dash or cluster housing using the original retaining nut. It will be necessary to cut the shaft for a nice custom installation.
2. Install the shaft in switch being certain that it is fully engaged inside the switch. Once the shaft is fully seated down inside the switch in the "off" position, place the knob on end of shaft. Measure how far away from the dash or cluster housing the bottom face of the knob (closest to dash) is. Allow for 1/4" or so extra so that the knob will not bottom out on dash or cluster housing once the shaft has been cut to length.
3. Remove the shaft from the switch. To do this, pull the shaft completely out to the "on" position. Depress the button on the metal chassis side of the switch and simply pull the shaft out of the switch. Cut the shaft based on your measurements.
4. Attach the knob to the cut shaft and tighten the Allen head screw.
5. Reinstall your newly customized shaft into your headlight switch assembly.



**American
Autowire**

www.americanautowire.com 856-933-0801

PART #

510698

DESCRIPTION:

Headlight Switch
1971-74 Mopar A-Body
Classic Update Series

92971838 instruction sheet rev 0.0 11/9/2017

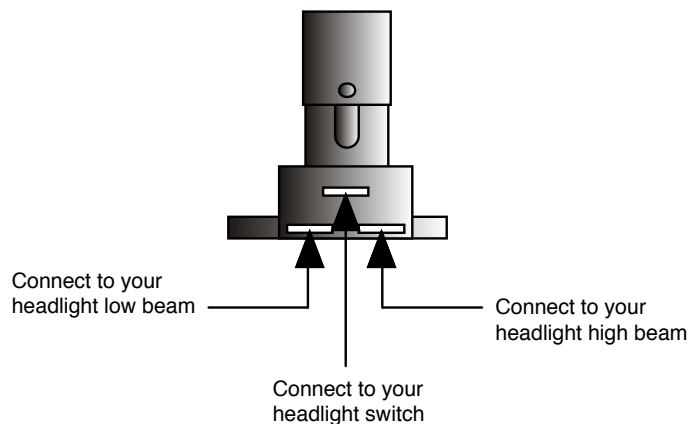

Connect the Dimmer Switch wires as shown above.

1. The top center terminal of the Dimmer Switch is connected to the Headlight switch.
2. The terminal on the right side is connected to your headlight high beam terminal.
3. The terminal on the left side is connected to your headlight low beam terminal.



www.americanautowire.com 856-933-0801

PART #

500042

DESCRIPTION:

DIMMER SWITCH

92964573 Rev 3.1 12/5/2014

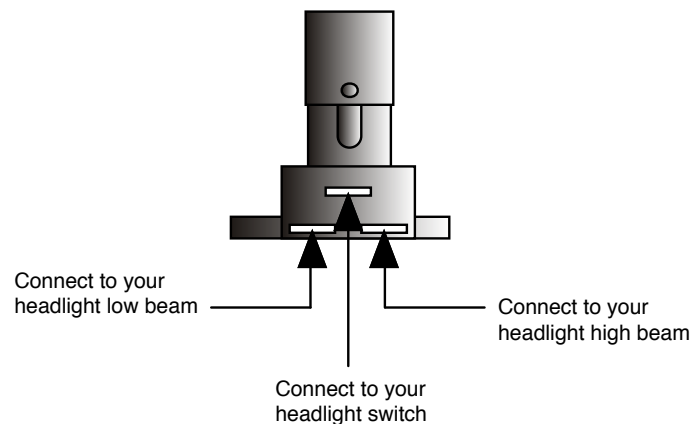

Connect the Dimmer Switch wires as shown above.

1. The top center terminal of the Dimmer Switch is connected to the Headlight switch.
2. The terminal on the right side is connected to your headlight high beam terminal.
3. The terminal on the left side is connected to your headlight low beam terminal.



www.americanautowire.com 856-933-0801

PART #

500042

DESCRIPTION:

DIMMER SWITCH

92964573 Rev 3.1 12/5/2014